



ORIGINAL INSTRUCTIONS

Instruction Manual

5 Port Solenoid Valve/Cassette Type Manifold

Series SZ3000

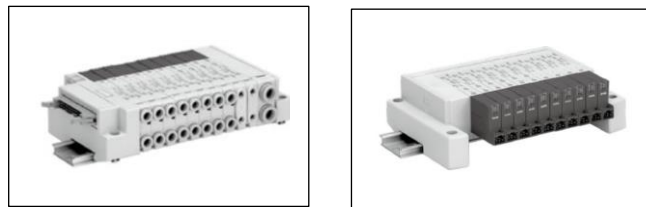

The intended use of this valve is to control the movement of an actuator.

1 Safety Instructions

These safety instructions are intended to prevent hazardous situations and/or equipment damage. These instructions indicate the level of potential hazard with the labels of "Caution," "Warning" or "Danger." They are all important notes for safety and must be followed in addition to International Standards (ISO/IEC^{*)}, and other safety regulations.

- *1) ISO 4414: Pneumatic fluid power - General rules relating to systems.
- ISO 4413: Hydraulic fluid power - General rules relating to systems.
- IEC 60204-1: Safety of machinery - Electrical equipment of machines. (Part 1: General requirements)
- ISO 10218-1: Robots and robotic devices - Safety requirements for industrial robots - Part 1: Robots.
- Refer to product catalogue, Operation Manual and Handling Precautions for SMC Products for additional information.
- Keep this manual in a safe place for future reference.

Caution	Caution indicates a hazard with a low level of risk which, if not avoided, could result in minor or moderate injury.
Warning	Warning indicates a hazard with a medium level of risk which, if not avoided, could result in death or serious injury.
Danger	Danger indicates a hazard with a high level of risk which, if not avoided, will result in death or serious injury.

Warning

- Always ensure compliance with relevant safety laws and standards.
- All work must be carried out in a safe manner by a qualified person in compliance with applicable national regulations.

Caution

- The product is provided for use in manufacturing industries only. Do not use in residential premises.

2 Specifications

2.1 Valve specifications

Fluid	Air	
Internal pilot operating pressure range [MPa]	2 position single	0.15 to 0.7
	2 position double	0.1 to 0.7
	3 position	0.2 to 0.7
External pilot pressure range [MPa]	4 position dual 3 port	0.15 to 0.7
	Operating pressure range	-100 kPa to 0.7
Ambien and fluid temperature [°C]	Pilot pressure range	0.25 to 0.7
	2 position single	
	2 position double	
Flow rate characteristics	3 position	Refer to catalogue
	4 position	
Response time	Contact SMC	
Duty cycle	1 cycle / 30 days	
Minimum operating frequency	10	
Maximum operating frequency [Hz]	2 position single, double, 4 position dual 3 port valve	3
	3 position	

2 Specifications - continued

Manual override (manual operation)	Non-locking push type Push-turn locking slotted type
Lubrication	Not required
Impact/Vibration resistance [m/s ²] Note	150 / 30
Enclosure (based on IEC60529)	IP40
Mounting orientation	Unrestricted
Weight	Refer to catalogue
Pilot type	Common exhaust

Table 1.

Note 1) Impact resistance: No malfunction occurred when it was tested in the axial direction and at right angles to the main valve and armature in both energized and de-energized states. Each condition was tested once. (Values quoted are for a new valve).
Vibration resistance: No malfunction occurred in a one-sweep test between 45 and 2000 Hz. Test was performed in both energized and de-energized states in the axial direction and at right angles to the main valve and armature. (Values quoted are for a new valve).

2.2 Solenoid specifications

Electrical entry	Plug-in, EX140, EX510	L type plug connector (L)
	Non plug-in	M type plug connector (M)
Coil rated voltage [VDC]	24, 12	
Allowable voltage fluctuation	±10% of rated voltage	
Coil insulation class	Contact SMC	
Power consumption [W]	0.6 (With light: 0.65)	
Surge voltage suppressor	Diode	
Indicator light	LED	

Table 2.

Note 1) Only 24 VDC and 12 VDC are available for plug-in use.

2.3 Manifold specifications

Model	D-sub Type 60F	Flat ribbon cable type 60P#			SS5Z3-60
		Type 60P	Type 60PG	Type 60PH	
Manifold type	Plug-in (L)				Non plug-in (M)
1(P: SUP)/3/5 (R: EXH) system	Common SUP, EXH				
Valve stations	2 to 20	2 to 16	2 to 8	2 to 20	

4(A)/2(B) port	Location	Valve
	Direction	Lateral, upward, downward
Port size	1(P), 3/5(R)	C8
	4(A), 2(B)	C4, C6, M5

Table 3.

2.4 Pneumatic symbols

Refer to catalogue Pneumatic symbols.

2.5 Indicator light

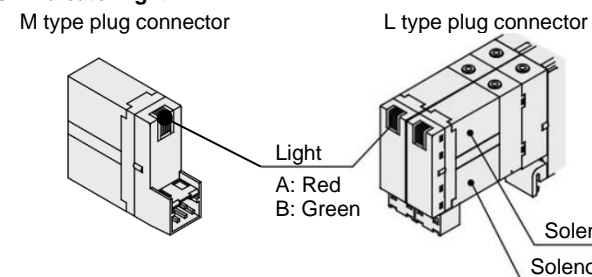

Figure 1.

2.6 Special products

Warning

Special products (-X) might have specifications different from those shown in this section. Contact SMC for specific drawings.

3 Installation

Warning

- Do not install the product unless the safety instructions have been read and understood.

3.2 Environment

Warning

- Do not use in an environment where corrosive gases, chemicals, salt water or steam are present.

3 Installation - continued

- Do not use in an explosive atmosphere.
- Do not expose to direct sunlight. Use a suitable protective cover.
- Do not install in a location subject to vibration or impact in excess of the product's specifications.
- Do not mount in a location exposed to radiant heat that would result in temperatures in excess of the product's specifications.

3.3 Piping

Caution

- Before connecting piping make sure to clean up chips, cutting oil, dust etc.
- When installing piping or fittings, ensure sealant material does not enter inside the port. When using seal tape, leave 1 thread exposed on the end of the pipe/fitting.
- Tighten fittings to the specified tightening torque.

3.4 Lubrication

Caution

- SMC products have been lubricated for life at manufacture, and do not require lubrication in service.
- If a lubricant is used in the system, refer to catalogue for details.

3.5 Air supply

Warning

- Use clean air. If the compressed air supply includes chemicals, synthetic materials (including organic solvents), salinity, corrosive gas etc., it can lead to damage or malfunction.

Caution

- Install an air filter upstream of the valve. Select an air filter with a filtration size of 5 µm or smaller.

3.6 Manual override

Warning

- Regardless of an electric signal for the valve, the manual override is used for switching the main valve. Since connected equipment will operate when the manual override is activated, confirm that conditions are safe prior to activation.
- Locked manual overrides might prevent the valve responding to being

electrically de-energised or cause unexpected movement in the equipment.

- Refer to the catalogue for details of manual override operation.

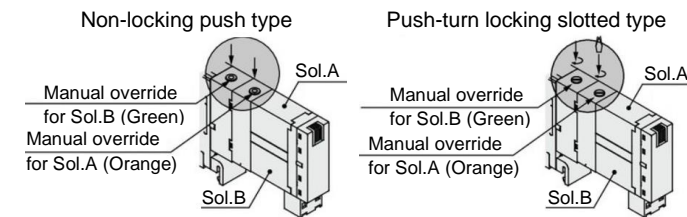

Figure 2. - Position is the same on L and M types

3.7 Valves with switches (L type plug-in only)

Warning

When turning OFF with the switch, be sure to move the switch to the locked position. Connected equipment may be actuated if current flow occurs with the switch at an improper position.

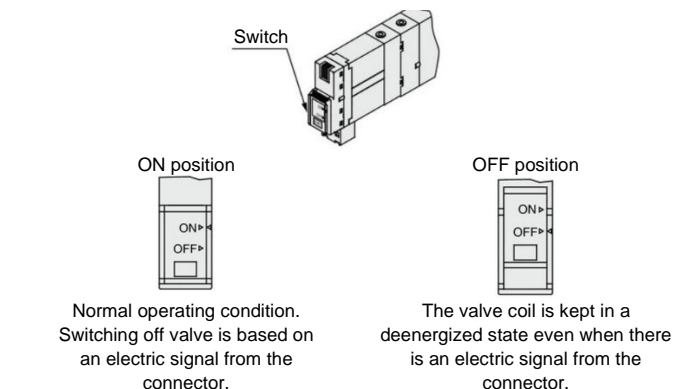

Figure 3.

3 Installation - continued

3.8 Electrical circuits

Caution

If a valve type without suppression is used, suppression should be provided as close as possible to the valve by the host controller.

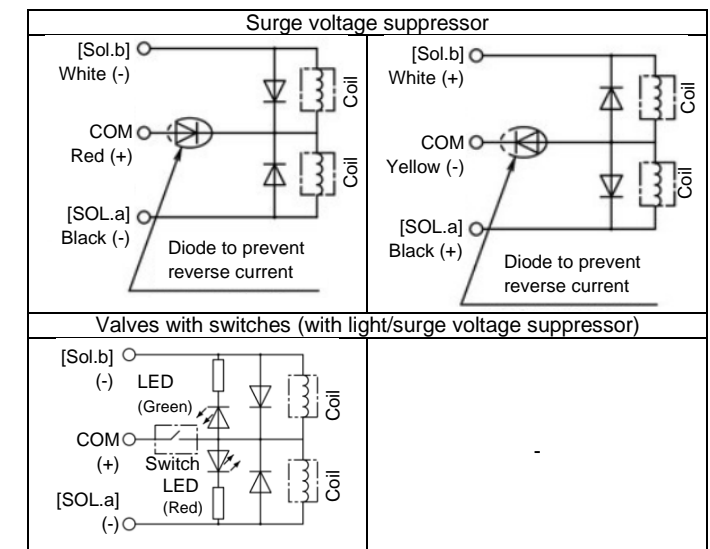
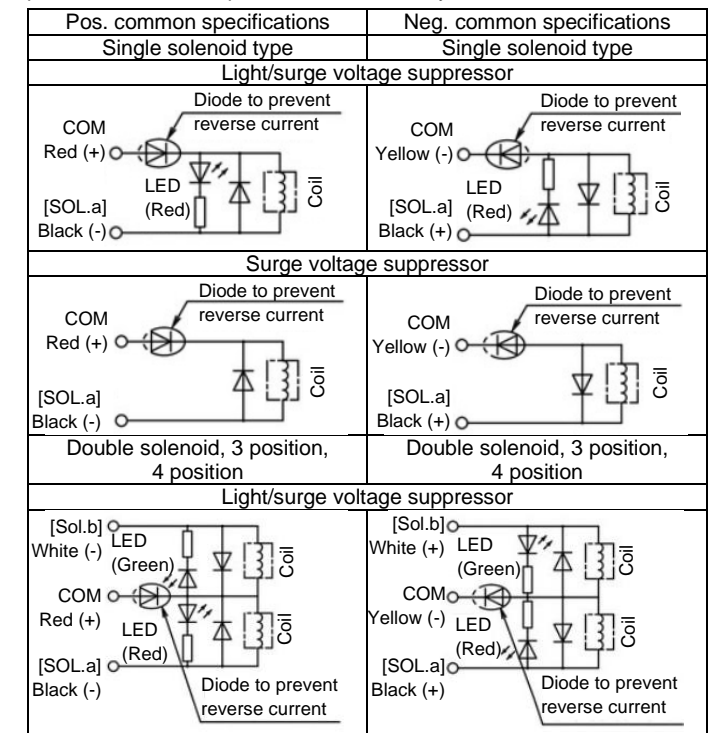

Figure 4.

Note) Make sure that the polarity is matched on the connector's (+), (-) and A, B and COM indicators. In case of voltage specifications other than 12 or 24 VDC, take care to avoid mistaking polarity, as there is no diode to prevent reverse current. In the event that lead wires are connected in advance, they will be as shown below.

Pos. common specifications	Neg. common specifications
A (-): Black	A (+): Black
COM (+): Red	COM (-): Red
B (-): White (no lead wire for single solenoid)	B (+): White (no lead wire for single solenoid)

3.9 Residual voltage

Caution

- The suppressor arrests the back EMF voltage from the coil to a level in proportion to the rated voltage.

3 Installation - continued

- Ensure the transient voltage is within the specification of the host controller.
- In the case of a diode, the residual voltage is approximately 1 V.
- Valve response time is dependent on surge suppression method selected.

3.10 Countermeasure for surge voltage

Caution

- At times of sudden interruption of the power supply, the energy stored in a large inductive device may cause non-polar type valves in a de-energised state to switch.
- When installing a breaker circuit to isolate the power, consider a valve with polarity (with polarity protection diode), or install a surge absorption diode across the output of the breaker.

3.11 Extended period of continuous energization

Warning

If a valve will be continuously energized for an extended period of time, the temperature of the valve will increase due to the heat generated by the coil assembly. This will likely adversely affect the performance of the valve and any nearby peripheral equipment. Therefore, if the valve is to be energized for periods of longer than 30 minutes at a time or if during the hours of operation the energized period per day is longer than the de-energized period, we advise using a 0.4 W or lower valves, such as the SY series, or a valve with power-saving circuit.

3.12 Effect of back pressure when using a manifold

Warning

- Use caution when valves are used on a manifold because an actuator may malfunction due to back-pressure.
- Special caution must be taken when using 3 position exhaust centre valve or when driving a single acting cylinder. To prevent a malfunction, implement counter measures such as using a single EXH spacer assembly or an individual exhaust manifold.

3.13 Manifold electrical wiring specifications

Refer to catalogue for manifold electrical wiring specifications.

3.14 How to use plug connector

Refer to catalogue for additional information.

3.14.1 Attaching and detaching connectors

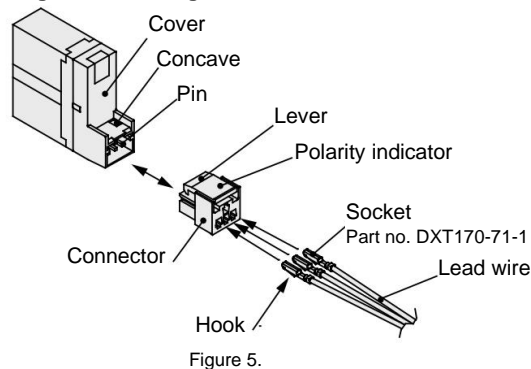

Figure 5.

3.14.2 Crimping of lead wires and sockets

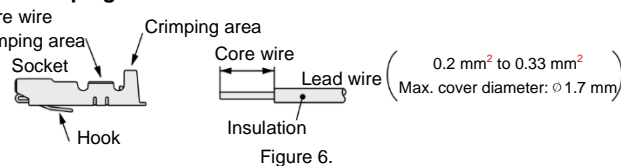

Figure 6.

3.14.3 Attaching and detaching lead wires with sockets

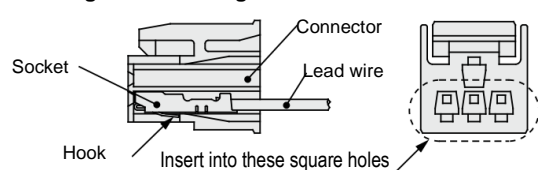

Figure 7.

3 Installation - continued

3.15 Common connector assembly wiring

Refer to catalogue for additional information.

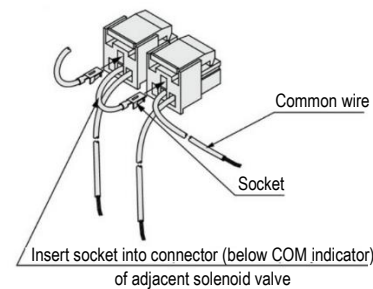

Figure 8. Common connector assembly wiring

3.16 Exhaust restriction

Caution

Since the SZ series is a type in which the pilot valve exhaust joins the main valve exhaust inside the valve, care must be taken that the piping from the exhaust port is not restricted.

3.17 Use as a 3-port valve

Caution

The SZ3000 series valves can be used as normally closed (N.C.) or normally open (N.O.) 3 port valves by closing one of the cylinder ports (A or B) with a plug. However, they should be used with the exhaust ports kept open. They are convenient at times when a double solenoid type 3 port valve is required.

Plug position		B port	A port
Type of actuation		N.C.	N.O.
Number of solenoids	Single		
	Double		

Table 4.

3.18 One-touch fittings

3.18.1 Tube attachment and detachment

Caution

Refer to the Specific Precautions in the catalogue.

3.18.2 Precautions on other tube brands

Caution

When using non-SMC brand tubes, refer to the Specific Precautions in the catalogue.

3.19 Built-in back pressure check valve

Caution

- Valves with built-in back pressure check valve is to protect the back pressure inside a valve. For this reason, use caution that the valves with external pilot specification cannot be pressurized from exhaust port [3(R)]. As compared with the types which do not integrate the back pressure check valve, C value of the flow rate characteristics goes down. For details, please contact SMC.
- Do not switch valves when A or B port is open to the atmosphere, or while the actuators and air operated equipment are in operation. The back pressure prevention seal may be peeled off, which may cause air leakage or malfunctions. Use caution especially when performing a trial operation or maintenance work.

4 Settings

4.1 Changing the connector entry direction

Caution

- Since lead wires are attached to the connector, excessive pulling or twisting can cause broken wires or other issues. Also, take care that lead wires are not pinched when installing the connector.
- If an excessive force is applied on the connector in the 'LOCK' position, the connector block may be damaged. Connector lead wires may break if the switch is in the 'FREE' position during operation. Ensure the switch is moved back in 'LOCK' position.
- Refer to catalogue for additional information.

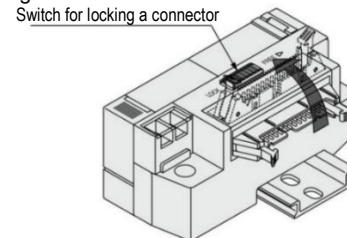

Figure 9.

5 How to Order

Refer to catalogue for 'How to Order' or to product drawing for special products.

6 Outline Dimensions

Refer to catalogue for outline dimensions.

7 Maintenance

7.1 General maintenance

Caution

- Not following proper maintenance procedures could cause the product to malfunction and lead to equipment damage.
- If handled improperly, compressed air can be dangerous.
- Maintenance of pneumatic systems should be performed only by qualified personnel.
- Before performing maintenance, turn off the power supply and be sure

to cut off the supply pressure. Confirm that the air is released to atmosphere.

- After installation and maintenance, apply operating pressure and power to the equipment and perform appropriate functional and leakage tests to make sure the equipment is installed correctly.
- If any electrical connections are disturbed during maintenance, ensure they are reconnected correctly and safety checks are carried out as required to ensure continued compliance with applicable national regulations.
- Do not make any modification to the product.
- Do not disassemble the product, unless required by installation or maintenance instructions.

7.2 Fitting assembly replacement

Refer to catalogue for additional information.

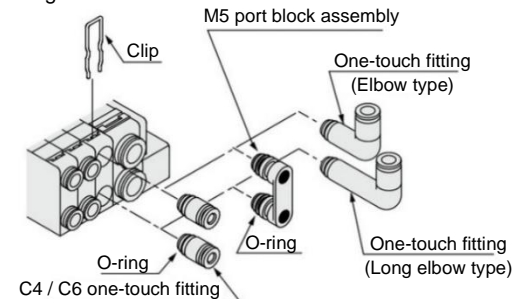

Figure 10.

7.3 Manifold expansion and replacement parts

- When disassembly and assembly are performed, air leakage may result if connections between blocks and tightening of the end block's holding screw, is inadequate. Before supplying air, confirm that there are no gaps, etc. between blocks, and that manifold blocks are securely fastened to the DIN rail. Then supply air and confirm that there is no air leakage before operating.
- Tighten the DIN rail holding screw to the recommended torque of 1.4 N·m.
- Refer to catalogue for additional information and replacement parts.

8 Limitations of Use

8.1 Limited warranty and disclaimer/compliance requirements

Refer to Handling Precautions for SMC Products.

Warning

8.2 Cannot be used as an emergency shut-off valve

This product is not designed for safety applications such as an emergency shut-off valve. If the valves are used in this type of system, other reliable safety assurance measures should be adopted.

8.3 Holding of pressure (including vacuum)

Since valves are subject to air leakage, they cannot be used for applications such as holding pressure (including vacuum) in a system.

8.4 Intermediate stopping

Refer to Handling Precautions for 3/4/5 port Solenoid Valves.

8.5 Air returned or air/spring returned spool valves

- The use of 2-position single valves with air returned or air/spring returned spools has to be carefully considered.
- The return of the valve spool into the de-energized position depends on the pilot pressure. If the pilot pressure drops below the specified operating pressure the position of the spool cannot be defined.
- The design of the system must take into account such behaviour.
- Additional measures might be necessary. For example, the installation of an additional air tank to maintain the pilot pressure. Such measures must be evaluated by risk assessment within the validation process.

Energy source status	Single	Double	3 position	4 position
Air supply present, electricity cut	Spool returns to the off position by air force	Spool stops moving after electricity cut (Position cannot be defined)	Spool returns to off position by spring force	Spools return to off position by air force
Air supply cut before electricity cut	Spool stops moving after air pressure cut (Position cannot be defined)	Spool stops moving after air pressure cut (Position cannot be defined)	Spool returns to off position by spring force (Position cannot be defined)	Spool stops moving after air pressure cut (Position cannot be defined)

Table 5.

Caution

8.6 Leakage voltage

Ensure that any leakage voltage caused by the leakage current when the switching element is OFF is $\leq 3\%$ of the rated voltage across the valve.

8.7 Low temperature operation

Unless otherwise indicated in the specifications for each valve, operation is possible to -10°C , but appropriate measures should be taken to avoid solidification or freezing of drainage and moisture, etc.

8.8 Momentary energization

If a double solenoid valve is operated with momentary energization, it should be energized for at least 0.1 second. However, depending on the secondary load conditions, it should be energized until the cylinder reaches the stroke end position, as there is a possibility of malfunction otherwise.

9 Product Disposal

This product shall not be disposed of as municipal waste. Check your local regulations and guidelines to dispose this product correctly, in order to reduce the impact on human health and the environment.

10 Contacts

Refer to www.smcworld.com or www.smc.eu for your local distributor/importer.

SMC Corporation

URL : <https://www.smcworld.com> (Global) <https://www.smc.eu> (Europe)
 SMC Corporation, 4-14-1, Sotokanda, Chiyoda-ku, Tokyo 101-0021, Japan
 Specifications are subject to change without prior notice from the manufacturer.
 © 2022 SMC Corporation All Rights Reserved.
 Template DKP50047-F-085M