

# Low Profile Single Axis Electric Actuator

## Series **LG1H**

### High Rigidity Direct Acting Guide

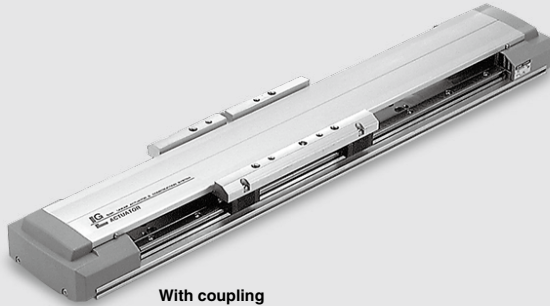

With coupling

Series	Motor type	Guide type	Mounting orientation	Motor/Screw connection	Model	Lead screw lead mm		Page
						Ground ball screw	Rolled ball screw	
LG1H	Standard motor	High rigidity direct acting guide	Horizontal	With coupling	LG1H21	10 20	10 20	Page 836 to

- Construction \_\_\_\_\_ Page 844
- Mounting \_\_\_\_\_ Page 845
- Deflection Data \_\_\_\_\_ Page 846

## Part Number Designations

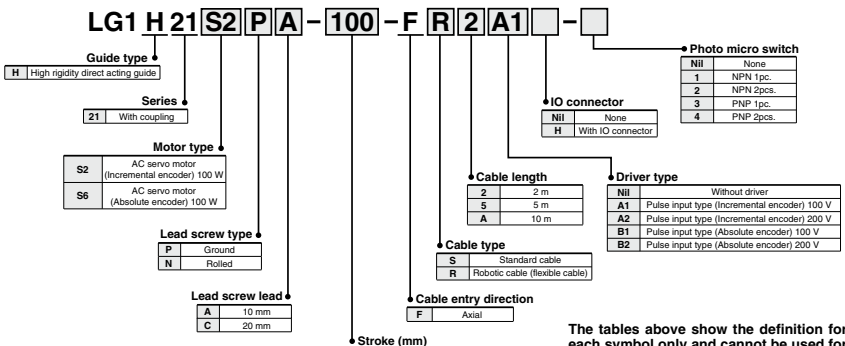

The tables above show the definition for each symbol only and cannot be used for actual model selection.

LJ1

LG1

LTF

LECS

LXF

LXP

LXS

LC6

LZ

LC3F2

D-

E-MY

# Standard Motor/ Horizontal Mount With Coupling

Motor Output  
**100 W**

High Rigidity  
Direct Acting  
Guide

Ground Ball Screw  
 $\varnothing 15$  mm / 10 mm lead

# Series LG1H21



## How to Order

LG1H21 **S2** **PA** - **300** - **F** **R** **2** **A1** - -

**Motor type**

S2	AC servo motor (Incremental encoder) 100 W
S6	AC servo motor (Absolute encoder) 100 W

**Stroke (mm)**  
Refer to the standard stroke.

**Cable type**

S	Standard cable
R	Robotic cable (flexible cable)

**Cable length**

2	2 m
5	5 m
A	10 m

**IO connector**

Nil	None
H	With IO connector

**Photo micro switch**

Nil	None
1	NPN 1pc.
2	NPN 2pcs.
3	PNP 1pc.
4	PNP 2pcs.

**Driver type**

Nil	Without driver
A1	Pulse input type (Incremental encoder) 100 V
A2	Pulse input type (Incremental encoder) 200 V
B1	Pulse input type (Absolute encoder) 100 V
B2	Pulse input type (Absolute encoder) 200 V

## Specifications

	Standard stroke (mm)	100	200	300	400
Performance	Body weight (kg)	5.3	6.1	6.9	7.7
	Operating temperature range (°C)	5 to 40 (No condensation)			
	Work load (kg)	30			
	Maximum speed (mm/s)	500			
	Positioning repeatability (mm)	±0.02			
Main parts	Motor	AC servo motor (100 W)			
	Encoder	Incremental system/Absolute type			
	Lead screw	Ground ball screw $\varnothing 15$ mm, 10 mm lead			
	Guide	High rigidity direct acting guide			
	Motor/Screw connection	With coupling			
Driver	Model	LECS□□□□ (Refer to page 885 for details.)			

## Allowable Moment (N·m)

### Allowable static moment

Pitching	142
Rolling	79
Yawing	150

m : Transfer load (kg)  
a : Workpiece acceleration (mm/s<sup>2</sup>)  
Me: Dynamic moment  
L : Overhang to workpiece center of gravity (mm)

### Allowable dynamic moment

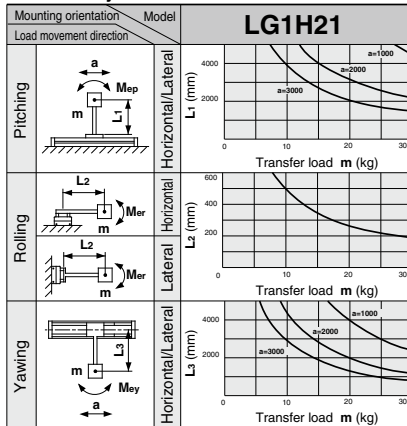

Refer to page 846 for deflection data.

## Investigation of the regeneration option

Depending on the conditions (speed, addition-subtraction speed, down time, load, etc.), the regeneration option may be required. The results of consideration in each case of maximum load or half load for the product specification are below. Please consult SMC when considering the necessity of the regeneration option.

### Maximum load

Driver type	Regeneration option model
A1	Not required.
A2	Not required.
B1	Not required.
B2	Not required.

### Half load

Driver type	Regeneration option model
A1	Not required.
A2	Not required.
B1	Not required.
B2	Not required.

# Standard Motor/Horizontal Mount Specification With Coupling **Series LG1H21**

## Dimensions/LG1H21□PA

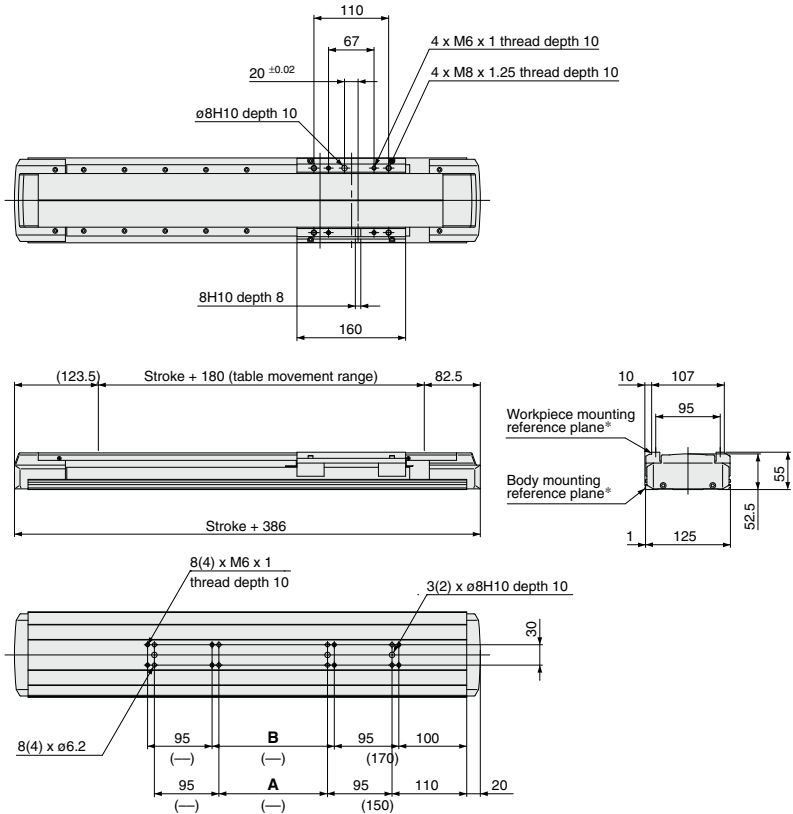

Model	Stroke	A	B
LG1H21□PA-100-F□*	100	—	—
LG1H21□PA-200-F□	200	60	80
LG1H21□PA-300-F□	300	160	180
LG1H21□PA-400-F□	400	260	280

\* Dimensions inside ( ) are for a 100 mm stroke.

\* The body mounting reference plane and workpiece mounting reference plane should be used as standards when mounting onto equipment. Refer to page 845 for mounting.

LJ1

LG1

LTF

LECS□

LXF

LXP

LXS

LC6□

LZ□

LC3F2

D-□

E-MY

## Positioning Time Guide

		Positioning time (sec.)					
Positioning distance (mm)		1	10	100	200	400	
Speed (mm/s)	10	0.5	1.4	10.4	20.4	40.4	
	100	0.5	0.6	1.5	2.5	4.5	
	250	0.5	0.6	0.9	1.3	2.1	
	500	0.5	0.6	0.8	1.0	1.4	

\* Values will vary slightly depending on the operating conditions.

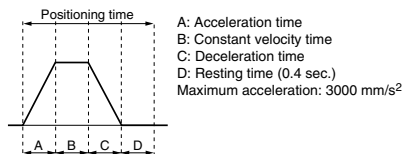

# Standard Motor/ Horizontal Mount With Coupling

Motor Output  
**100 W**

High Rigidity  
Direct Acting  
Guide

Ground Ball Screw  
 $\varnothing 15$  mm / 20 mm lead

# Series LG1H21



## How to Order

**LG1H21 S2 PC - 500 - F R 2 A1** - [ ] - [ ]

**Motor type**

S2	AC servo motor (Incremental encoder) 100 W
S6	AC servo motor (Absolute encoder) 100 W

**Stroke (mm)**  
Refer to the standard stroke.

**Cable type**

S	Standard cable
R	Robotic cable (flexible cable)

**Cable length**

2	2 m
5	5 m
A	10 m

**IO connector**

Nil	None
H	With IO connector

**Photo micro switch**

Nil	None
1	NPN 1pc.
2	NPN 2pcs.
3	PNP 1pc.
4	PNP 2pcs.

**Driver type**

Nil	Without driver
A1	Pulse input type (Incremental encoder) 100 V
A2	Pulse input type (Incremental encoder) 200 V
B1	Pulse input type (Absolute encoder) 100 V
B2	Pulse input type (Absolute encoder) 200 V

## Specifications

Standard stroke (mm)		500	600	700	800	900	1000
Performance	Body weight (kg)	8.5	9.3	10.1	10.9	11.7	12.5
	Operating temperature range (°C)	5 to 40 (No condensation)					
	Work load (kg)	30					
	Maximum speed (Note) (mm/s)	1000	1000	930	740	600	500
	Positioning repeatability (mm)	±0.02					
Main parts	Motor	AC servo motor (100 W)					
	Encoder	Incremental system/Absolute type					
	Lead screw	Ground ball screw $\varnothing 15$ mm, 20 mm lead					
	Guide	High rigidity direct acting guide					
Driver	Motor/Screw connection	With coupling					
	Model	LECS□□□□ (Refer to page 885 for details.)					

(Note) The speed is limited by the transfer load. Refer to the maximum speeds for each transfer load on page 839.

## Allowable Moment (N·m)

### Allowable static moment

Pitching	142
Rolling	79
Yawing	150

**m** : Transfer load (kg)  
**a** : Workpiece acceleration (mm/s<sup>2</sup>)  
**M<sub>e</sub>** : Dynamic moment  
**L** : Overhang to workpiece center of gravity (mm)

### Allowable dynamic moment

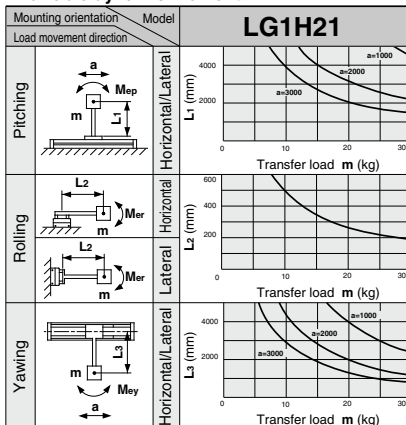

Refer to page 846 for deflection data.

## Investigation of the regeneration option

Depending on the conditions (speed, addition-subtraction speed, down time, load, etc.), the regeneration option may be required. The results of consideration in each case of maximum load or half load for the product specification are below. Please consult SMC when considering the necessity of the regeneration option.

### Maximum load

Driver type	Regeneration option model
A1	LEC-MR-RB-032
A2	Not required.
B1	LEC-MR-RB-032
B2	Not required.

### Half load

Driver type	Regeneration option model
A1	Not required.
A2	Not required.
B1	Not required.
B2	Not required.

# Standard Motor/Horizontal Mount Specification With Coupling **Series LG1H21**

## Dimensions/LG1H21□PC

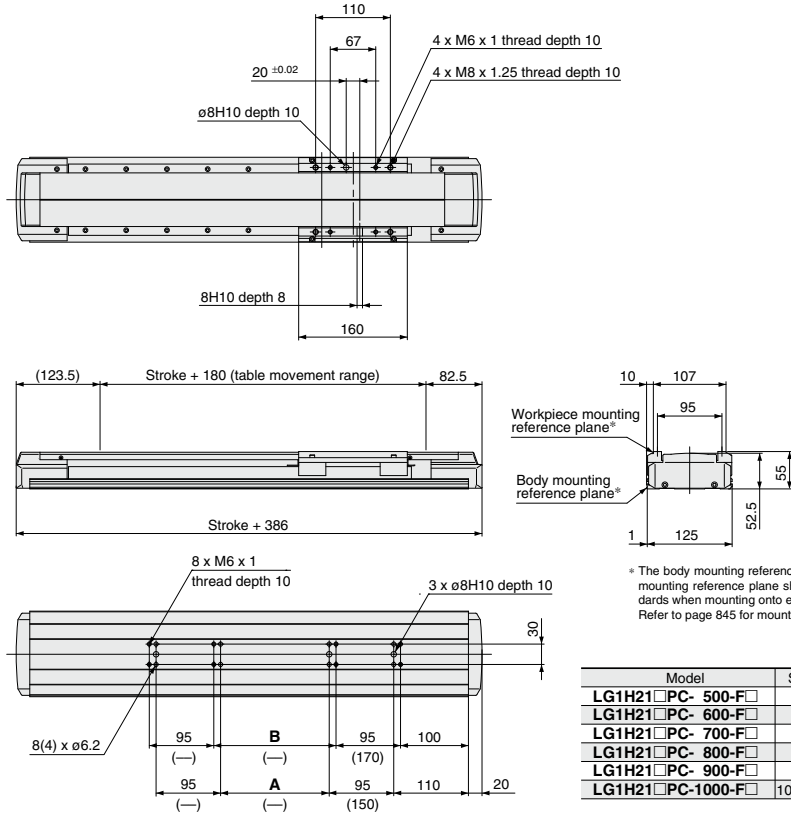

Model	Stroke	A	B
LG1H21□PC- 500-F□	500	360	380
LG1H21□PC- 600-F□	600	460	480
LG1H21□PC- 700-F□	700	560	580
LG1H21□PC- 800-F□	800	660	680
LG1H21□PC- 900-F□	900	760	780
LG1H21□PC-1000-F□	1000	860	880

## Positioning Time Guide

Positioning distance (mm)	Positioning time (sec.)					
	1	10	100	500	1000	
Speed (mm/s)	10	0.5	1.5	10.5	50.5	100.5
	100	0.5	0.6	1.5	5.5	10.5
	500	0.5	0.6	0.9	1.7	2.7
	1000	0.5	0.6	0.9	1.4	1.9

\* Values will vary slightly depending on the operating conditions.

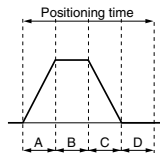

A: Acceleration time  
B: Constant velocity time  
C: Deceleration time  
D: Resting time (0.4 sec.)  
Maximum acceleration: 2000 mm/s<sup>2</sup>

## Maximum Speeds for Each Transfer Load

Model	Transfer load (kg)				Unit (mm/s)
	15	20	25	30	
LG1H21□PC-500-F□	1000	700	500	500	
LG1H21□PC-600-F□	1000	700	500	500	
LG1H21□PC-700-F□	930	600	500	500	
LG1H21□PC-800-F□	740	600	500	500	
LG1H21□PC-900-F□	600	500	500	500	
LG1H21□PC-1000-F□	500	500	500	500	

\* Consult SMC if outside of the above conditions.

# Standard Motor/ Horizontal Mount With Coupling

Motor Output

100 W

High Rigidity  
Direct Acting  
Guide

Rolled Ball Screw

∅15 mm/10 mm lead

# Series LG1H21



## How to Order

**LG1H21 S2 NA - 300 - F R 2 A1** - -

**Motor type**

S2	AC servo motor (Incremental encoder) 100 W
S6	AC servo motor (Absolute encoder) 100 W

**Stroke (mm)**  
Refer to the standard stroke.

**Cable type**

S	Standard cable
R	Robotic cable (flexible cable)

**Cable length**

2	2 m
5	5 m
A	10 m

**IO connector**

Nil	None
H	With IO connector

**Photo micro switch**

Nil	None
1	NPN 1pc.
2	NPN 2pcs.
3	PNP 1pc.
4	PNP 2pcs.

**Driver type**

Nil	Without driver
A1	Pulse input type (Incremental encoder) 100 V
A2	Pulse input type (Incremental encoder) 200 V
B1	Pulse input type (Absolute encoder) 100 V
B2	Pulse input type (Absolute encoder) 200 V

## Specifications

	Standard stroke (mm)	100	200	300	400
Performance	Body weight (kg)	5.3	6.1	6.9	7.7
	Operating temperature range (°C)	5 to 40 (No condensation)			
	Work load (kg)	30			
	Maximum speed (mm/s)	500			
	Positioning repeatability (mm)	±0.05			
Main parts	Motor	AC servo motor (100 W)			
	Encoder	Incremental system/Absolute type			
	Lead screw	Rolled ball screw ∅15 mm, 10 mm lead			
	Guide	High rigidity direct acting guide			
Driver	Motor/Screw connection	With coupling			
	Model	LECS□□□□ (Refer to page 885 for details.)			

## Allowable Moment (N-m)

### Allowable static moment

Pitching	142
Rolling	79
Yawing	150

m : Transfer load (kg)  
a : Workpiece acceleration (mm/s<sup>2</sup>)  
Me : Dynamic moment  
L : Overhang to workpiece center of gravity (mm)

### Allowable dynamic moment

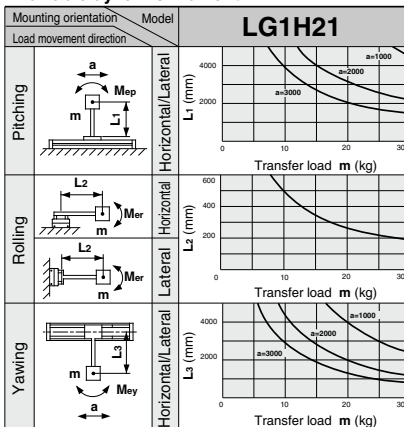

Refer to page 846 for deflection data.

## Investigation of the regeneration option

Depending on the conditions (speed, addition-subtraction speed, down time, load, etc.), the regeneration option may be required.

The results of consideration in each case of maximum load or half load for the product specification are below.

Please consult SMC when considering the necessity of the regeneration option.

### Maximum load

Driver type	Regeneration option model
A1	Not required.
A2	Not required.
B1	Not required.
B2	Not required.

### Half load

Driver type	Regeneration option model
A1	Not required.
A2	Not required.
B1	Not required.
B2	Not required.

# Standard Motor/Horizontal Mount Specification With Coupling **Series LG1H21**

## Dimensions/LG1H21□NA

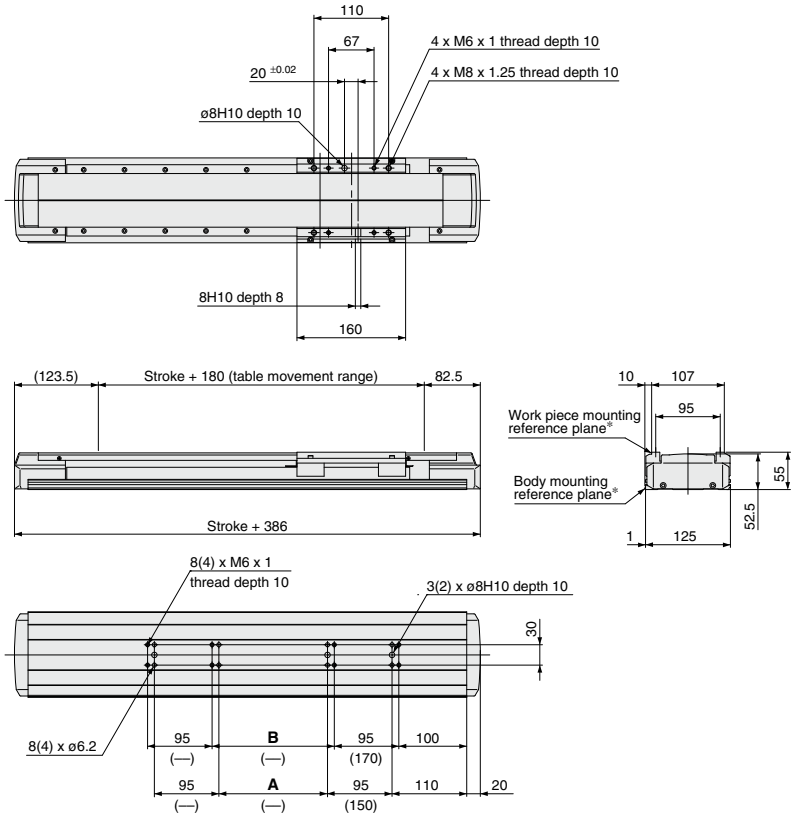

Model	Stroke	A	B
LG1H21□NA-100-F□*	100	—	—
LG1H21□NA-200-F□	200	60	80
LG1H21□NA-300-F□	300	160	180
LG1H21□NA-400-F□	400	260	280

\* Dimensions inside ( ) are for a 100 mm stroke.

\* The body mounting reference plane and workpiece mounting reference plane should be used as standards when mounting onto equipment. Refer to page 845 for mounting.

- LJ1
- LG1**
- LTF
- LECS□
- LXF
- LXP
- LXS
- LC6□
- LZ□
- LC3F2
- D-□
- E-MY

## Positioning Time Guide

		Positioning time (sec.)				
		1	10	100	200	400
Speed (mm/s)	10	0.5	1.4	10.4	20.4	40.4
	100	0.5	0.6	1.5	2.5	4.5
	250	0.5	0.6	0.9	1.3	2.1
	500	0.5	0.6	0.8	1.0	1.4

\* Values will vary slightly depending on the operating conditions.

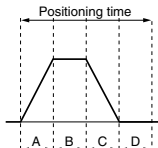

A: Acceleration time  
 B: Constant velocity time  
 C: Deceleration time  
 D: Resting time (0.4 sec.)  
 Maximum acceleration: 3000 mm/s<sup>2</sup>

# Standard Motor/ Horizontal Mount With Coupling

Motor Output  
**100 W**

High Rigidity  
Direct Acting  
Guide

Rolled Ball Screw  
 $\varnothing 15$  mm / 20 mm lead

# Series LG1H21



## How to Order

**LG1H21 S2 NC - 500 - F R 2 A1**

**Motor type**

S2	AC servo motor (Incremental encoder) 100 W
S6	AC servo motor (Absolute encoder) 100 W

**Stroke (mm)**  
Refer to the standard stroke.

**Cable type**

S	Standard cable
R	Robotic cable (flexible cable)

**Cable length**

2	2 m
5	5 m
A	10 m

**IO connector**

Nil	None
H	With IO connector

**Photo micro switch**

Nil	None
1	NPN 1pc.
2	NPN 2pcs.
3	PNP 1pc.
4	PNP 2pcs.

**Driver type**

Nil	Without driver
A1	Pulse input type (Incremental encoder) 100 V
A2	Pulse input type (Incremental encoder) 200 V
B1	Pulse input type (Absolute encoder) 100 V
B2	Pulse input type (Absolute encoder) 200 V

## Specifications

Standard stroke (mm)		500	600	700	800	900	1000
Performance	Body weight (kg)	8.5	9.3	10.1	10.9	11.7	12.5
	Operating temperature range (°C)	5 to 40 (No condensation)					
	Work load (kg)	30					
	Maximum speed (mm/s)	1000	1000	930	740	600	500
Positioning repeatability (mm)		±0.05					
Main parts	Motor	AC servo motor (100 W)					
	Encoder	Incremental system/Absolute type					
	Lead screw	Rolled ball screw $\varnothing 15$ mm, 20 mm lead					
	Guide	High rigidity direct acting guide					
Motor/Screw connection		With coupling					
Driver	Model	LECS□□-□ (Refer to page 885 for details.)					

(Note) The speed is limited by the transfer load. Refer to the maximum speeds for each transfer load on page 843.

## Allowable Moment (N·m)

### Allowable static moment

Pitching	142
Rolling	79
Yawing	150

m : Transfer load (kg)  
a : Workpiece acceleration (mm/s<sup>2</sup>)

Me : Dynamic moment  
L : Overhang to workpiece center of gravity (mm)

### Allowable dynamic moment

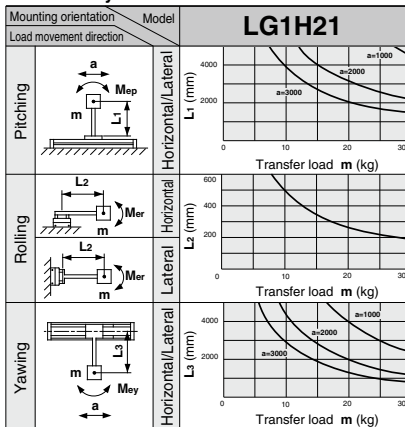

Refer to page 846 for deflection data.

## Investigation of the regeneration option

Depending on the conditions (speed, addition-subtraction speed, down time, load, etc.), the regeneration option may be required. The results of consideration in each case of maximum load or half load for the product specification are below. Please consult SMC when considering the necessity of the regeneration option.

### Maximum load

Driver type	Regeneration option model
A1	LEC-MR-RB-032
A2	Not required.
B1	LEC-MR-RB-032
B2	Not required.

### Half load

Driver type	Regeneration option model
A1	Not required.
A2	Not required.
B1	Not required.
B2	Not required.



**Dimensions/LG1H21□NC**

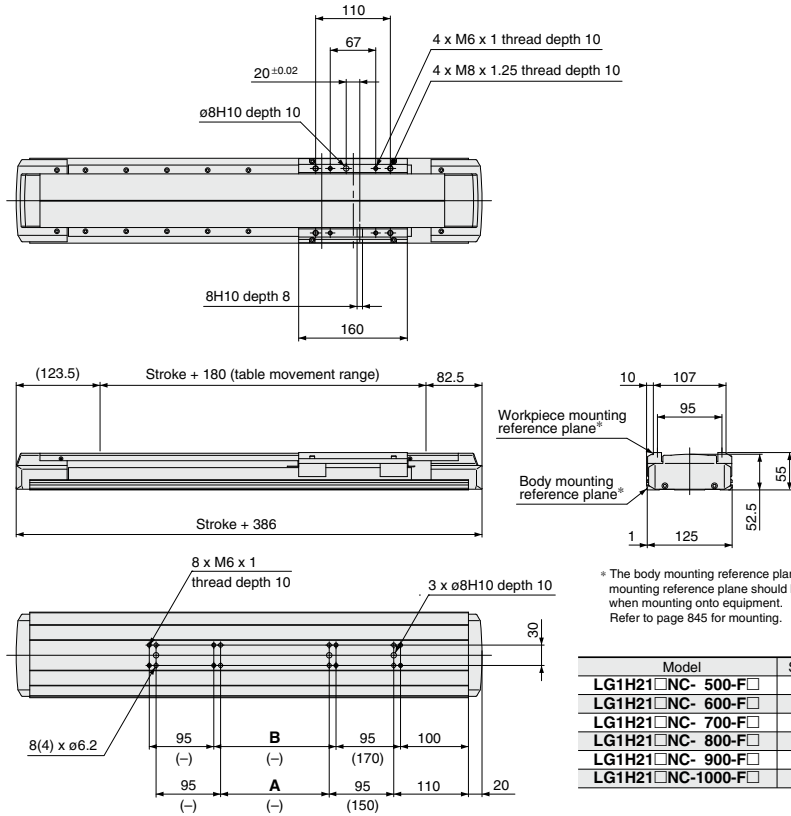

**Positioning Time Guide**

Positioning distance (mm)		Positioning time (sec.)				
		1	10	100	500	1000
Speed (mm/s)	10	0.5	1.5	10.5	50.5	100.5
	100	0.5	0.6	1.5	5.5	10.5
	500	0.5	0.6	0.9	1.7	2.7
	1000	0.5	0.6	0.9	1.4	1.9

\* Values will vary slightly depending on the operating conditions.

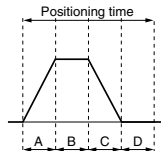

A: Acceleration time  
B: Constant velocity time  
C: Deceleration time  
D: Resting time (0.4 sec.)  
Maximum acceleration: 2000 mm/s<sup>2</sup>

**Maximum Speeds for Each Transfer Load**

Model	Transfer load (kg)			
	15	20	25	30
LG1H21□NC-500-F□	1000	700	500	500
LG1H21□NC-600-F□	1000	700	500	500
LG1H21□NC-700-F□	930	600	500	500
LG1H21□NC-800-F□	740	600	500	500
LG1H21□NC-900-F□	600	500	500	500
LG1H21□NC-1000-F□	500	500	500	500

Unit (mm/s)

\* Consult SMC if outside of the above conditions.

# Series LG1H

## Construction/ With Coupling

### LG1H21

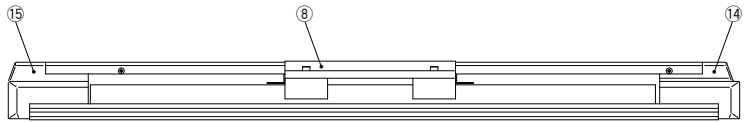
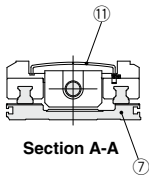
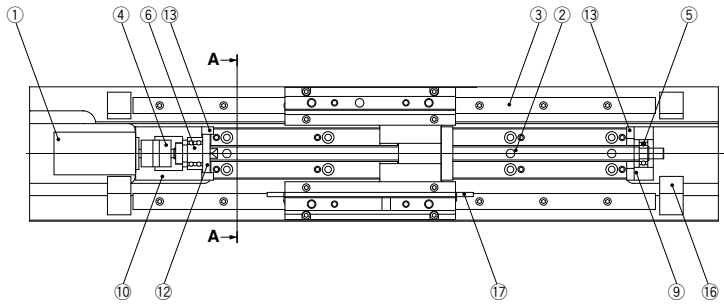

#### Parts list

No.	Description	Material	Note
1	AC servo motor	—	100 W
2	Lead screw	—	Ball screw
3	High rigidity direct acting guide	—	
4	Coupling	—	
5	Bearing R	—	
6	Bearing F	—	
7	Body	Aluminum alloy	
8	Table	Aluminum alloy	
9	Housing A	Aluminum alloy	
10	Housing B	Aluminum alloy	

No.	Description	Material	Note
11	Top cover	Aluminum alloy	
12	Bearing retainer	Aluminum alloy	
13	Bumper	IFR	
14	End cover A	PC	
15	End cover B	PC	
16	Photo micro sensor	—	
17	Sensor plate	—	

# Series LG1H Mounting

## Top Mount

### LG1H21/ With coupling

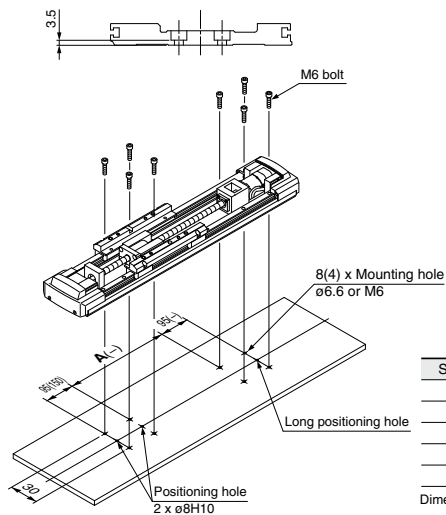

Stroke	A	Stroke	A
100	—	600	460
200	60	700	560
300	160	800	660
400	260	900	760
500	360	1000	860

Dimensions inside ( ) are for a 100 mm stroke.

## Bottom Mount

### LG1H21/ With coupling

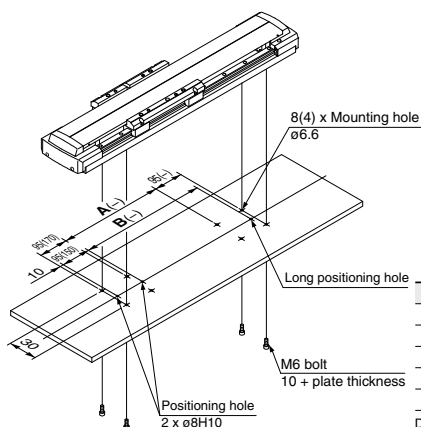

Stroke	A	B	Stroke	A	B
100	—	—	600	480	555
200	80	155	700	580	655
300	180	255	800	680	755
400	280	355	900	780	855
500	380	455	1000	880	955

Dimensions inside ( ) are for a 100 mm stroke.

LJ1

LG1

LTF

LECS □

LXF

LXP

LXS

LC6 □

LZ □

LC3F2

D-□

E-MY

# Series LG1H

## Deflection Data

### Deflection Data

\* Calculated values based on the body's sectional secondary moment.

The load and the amount of deflection at load point W are shown in the graphs below.

#### LG1H/ Aluminum body

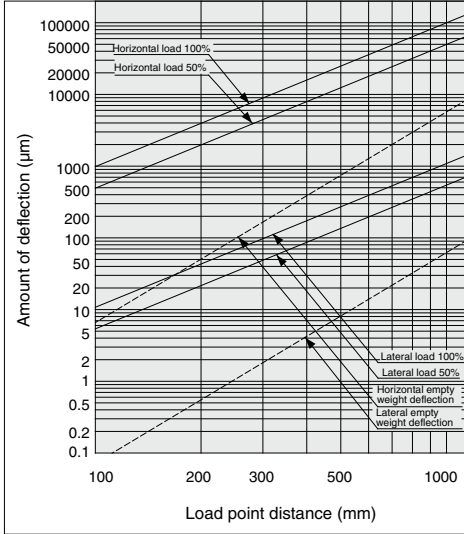

With single end support and table moved to the end of the stroke

