

# Electric Cylinder

## LZB/LZC Series



*It can be operated like an air cylinder.*



**LZB Series**

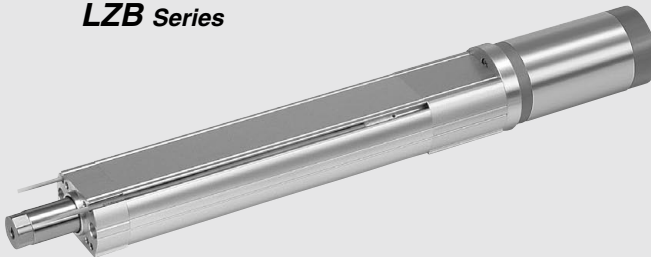

**LZC Series**

- LEF
- LEJ
- LEL
- LEM
- LEY
- LES
- LEPY  
LEPS
- LER
- LEH
- LEY  
-X5
- 11-  
LEFS
- 11-  
LEJS
- 25A-
- LEC
- LEC  
S
- LEC  
SS-T
- LEC  
Y
- Motor-  
less
- LAT
- LZ
- LC3F2

Model	Max. thrust	Max. speed	Lead screw	Stroke
<b>LZB</b>	196 N	200 mm/s	Slide screw: $\phi 8, \phi 12$ Lead: 2, 6, 12	25, 40, 50, 100, 200
<b>LZC</b>				

- **System Chart** ..... P.926
- **Model Selection** ..... P.927
- **Electric Cylinder/LZB** ..... P.928
- **Electric Cylinder/LZC** ..... P.934
- **LZB/C Vertical Application Specifications** ..... P.938
- **Accessories** ..... P.939
- **Auto Switch Proper Mounting Position (Detection at Stroke End) and It's Mounting Height** ..... P.941
- **Mounting and Moving Auto Switches** ..... P.942

# LZ□ Series System Chart

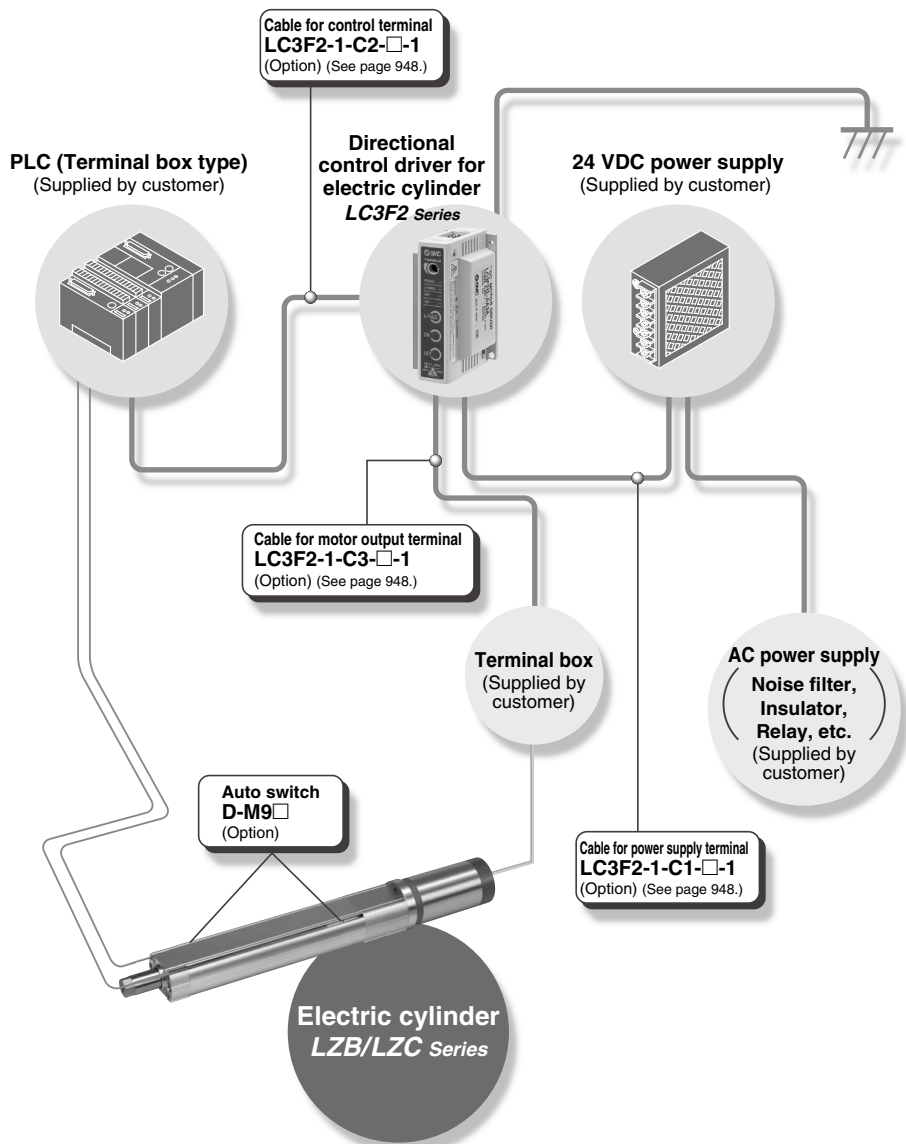

# LZB/LZC Series

## Model Selection

Note) These graphs are made using actual data. Therefore these graphs are to be used as a reference and are not a guarantee of product's performance in any case. The graphs may change depending on the operating condition or environment.

### Horizontal Motion of Pressing Force

**Model selection condition 1)**  
Used as a force-pressing, 50 N or greater pressing force is required.



**Model selection result 1)**  
From Graph 1, LZB/C□3's lead 2 is applicable. (Pressing force: 80 N)

**Graph 1 LZ□3: [Speed-Thrust] Relationship Graph**

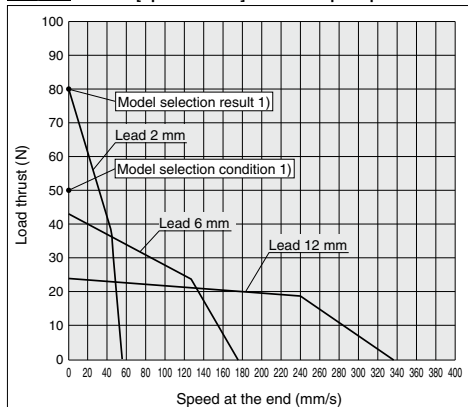

### Horizontal Transfer

**Model selection condition 2)**  
Used as a transfer, 60 N transfer thrust and 40 mm/s transfer speed are required.



**Model selection result 2)**  
From Graph 2, LZB/C□5's lead 6 mm and lead 12 mm are applicable. But, speed at the end with 60 N load will be 100 mm/s for lead 6 mm and 60 mm/s for lead 12 mm. Select a suitable product in accordance with the customer's equipment.

**Graph 2 LZ□5: [Speed-Thrust] Relationship Graph**

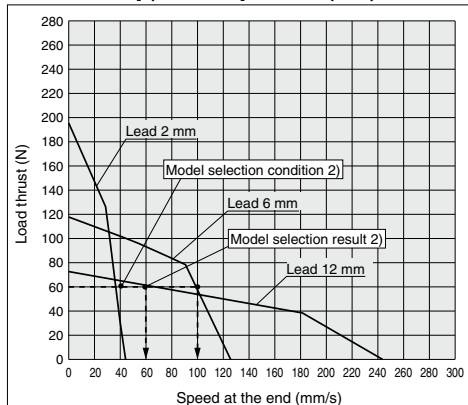

### Speed-Thrust Graph (Horizontal Operation)

**LZ□3**

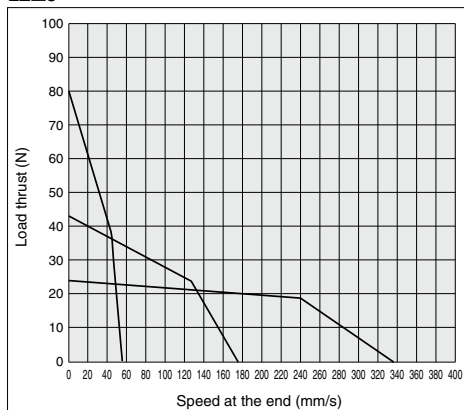

**LZ□5**

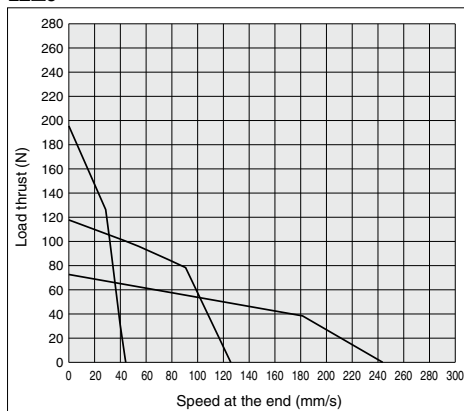

LEF

LEJ

LEL

LEM

LEY

LES

LEPY

LEPS

LER

LEH

LEY

-X5

11-LEFS

11-LEJS

25A-

LEC□

LEC

S□

LEC

SS-T

LEC

Y□

Motor-

less

LAT

LZ□

LC3F2

# Electric Cylinder LZB Series



## How to Order

**With auto switch** LZB B 3 L - 100 A 3 - M9B

**Built-in magnet**

**Mounting type**

B	Basic type
L	Axial foot type
F	Rod flange type
U	Rod trunnion type

**Cylinder size**

3	Equivalent to ø16 cylinder (N30)
5	Equivalent to ø25 cylinder (N50)

Note) Equivalent to 0.4 MPa, theoretical output (lead 2)  
For details, refer to page 927 "Speed - Thrust Graph".

**Thread lead (mm)**

L	Lead 2
M	Lead 6
H	Lead 12

**Stroke (mm)**  
Refer to "Standard Stroke" table.

**Number of auto switches**

Nil	2 pcs.
S	1 pc.
n	n

**Auto switch**

Nil	Without auto switch (Built-in magnet)
-----	---------------------------------------

\* Refer to the table below for auto switch model numbers.  
\* Auto switches are shipped together (not assembled).

**Rod end thread**

Nil	Female
L	Male

\* Rod end male thread is shipped together.

**Motor size**

3	Applicable cylinder size 3
5	Applicable cylinder size 5

**Motor type**

A	DC motor
---	----------

### Standard Stroke

Cylinder size	Standard stroke (mm) *
3, 5	25, 40, 50, 100, 200

- \* Other intermediate strokes can be manufactured upon receipt of order.  
(Maximum manufacturable stroke: 200 mm)  
Conditions for using a trunnion bracket are as follows:
- Maximum stroke: 150 mm
  - Thread lead L (lead 2 mm) only

### Applicable Auto Switches

For detailed auto switch specifications, refer to page 944.

Type	Special function	Electrical entry	Indicator light	Wiring (Output)	Load voltage		Auto switch model	Lead wire length (m) *				Pre-wired connector	Applicable load	
					DC	AC		0.5 (Nil)	1 (M)	3 (L)	5 (Z)		IC circuit	Relay PLC
Solid state auto switch	—	Grommet	Yes	3-wire (NPN)	24 V	5 V	—	M9B	●	●	○	○	—	—
				3-wire (PNP)		12 V		M9P	●	●	○	○		
				2-wire		12 V		M9B	●	●	○	○		

- \* Lead wire length symbols: 0.5 m ..... Nil (Example) M9B  
1 m ..... M M9BM  
3 m ..... L M9BL  
5 m ..... Z M9BZ

- \* Solid state auto switches marked "○" are produced upon receipt of order.

## Specifications



Model	LZB□3L	LZB□3M	LZB□3H	LZB□5L	LZB□5M	LZB□5H
Size	3 (Equivalent to ø16 cylinder) <sup>Note 1)</sup>			5 (Equivalent to ø25 cylinder) <sup>Note 1)</sup>		
Lead screw	Thread diameter					
	ø8			ø12		
	Lead (mm)					
	2	6	12	2	6	12
Rated speed with no load (mm/s) <sup>Note 2)</sup>	33 or more	100 or more	200 or more	33 or more	100 or more	200 or more
Rated thrust (N) <sup>Note 3)</sup>	80 or more	43 or more	24 or more	196 or more	117 or more	72 or more
Stroke (mm)	25, 40, 50, 100, 200					
Main body (kg)*	0.67 + (0.07/50 stroke)			1.74 + (0.16/50 stroke)		
Operating ambient temperature (°C)	5 to 40 (No condensation)					
Allowable tolerance of stroke	$\begin{matrix} +1 \\ 0 \end{matrix}$					
Motor	DC motor					
Applicable directional control driver model	LC3F212-5A3□			LC3F212-5A5□		
Applicable auto switch model	D-M9N, M9P, M9B					

Note 1) Equivalent to 0.4 MPa, theoretical output (lead 2)

Note 2) In the table speeds are shown without a load, as rated speed, and thrusts are shown as rated thrust based on the pressure force.

Note 3) Speed will vary as they are affected by a load. Refer to page 927 for model selection.

\* Refer to page 939 for mounting bracket weight.

## ⚠ Specific Product Precautions

- Do not apply any lateral load to the rod of the LZB series. When applying a lateral load, use a guide to avoid the load from being applied to the rod.

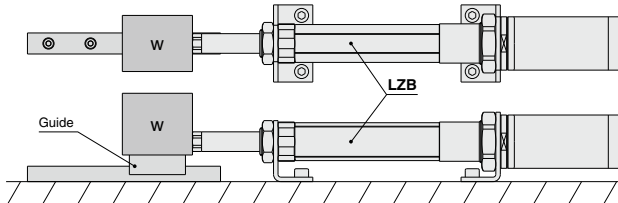

## 2. Auto switch mounting

There are 4 grooves on the outside surface of the cylinder tube, indicating the auto switch installation range. Mount the auto switches within the range shown below.

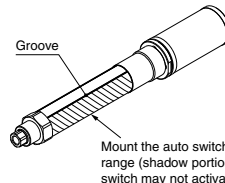
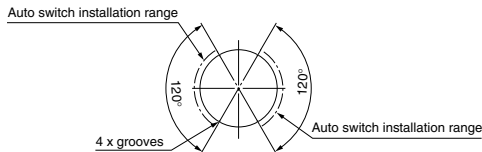

\* Refer to pages 941 and 942 for information on mounting an auto switch.

- LEF
- LEJ
- LEL
- LEM
- LEY
- LES
- LEPY
- LEPS
- LER
- LEH
- LEY
- X5
- 11-
- LEFS
- 11-
- LEJS
- 25A-
- LEC□
- LEC
- S□
- LEC
- SS-T
- LEC
- Y□
- Motor-
- less
- LAT
- LZ□
- LC3F2

# LZB Series

## Dimensions Note) Grounding must be performed.

### L(D)ZBB3□

\* The electrical entry direction is different depending on the product.

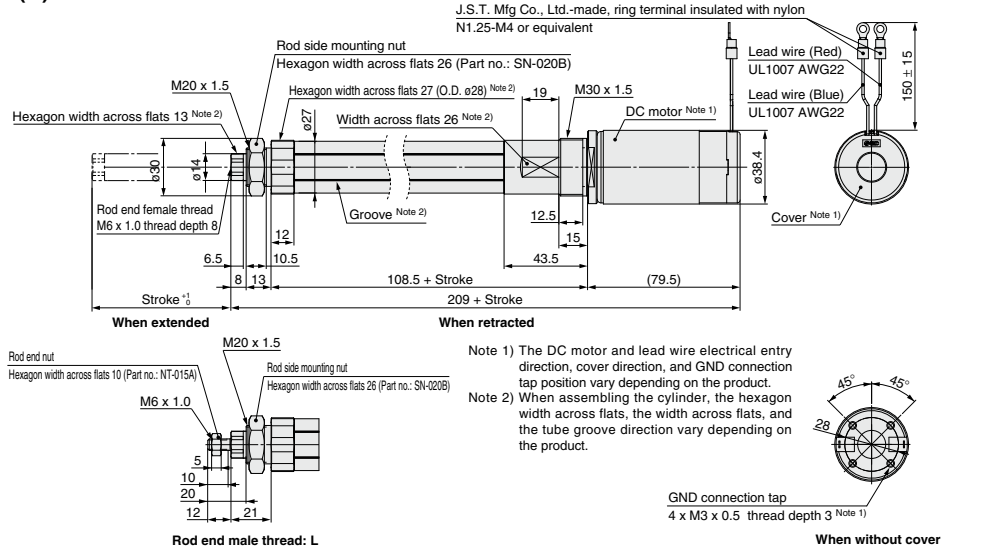

### Axial foot type/L(D)ZBL3□

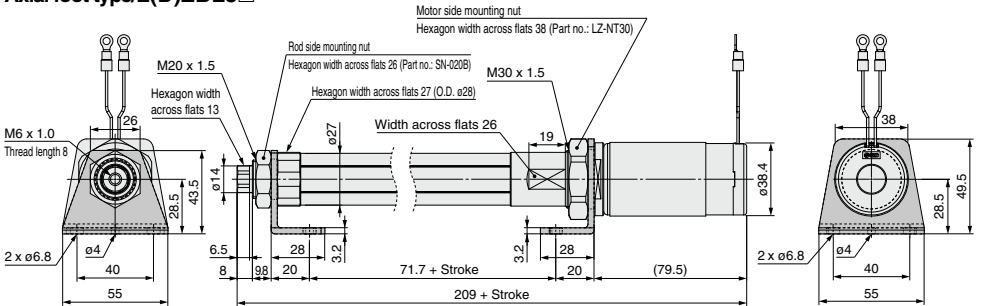

### Rod flange type/L(D)ZBF3□

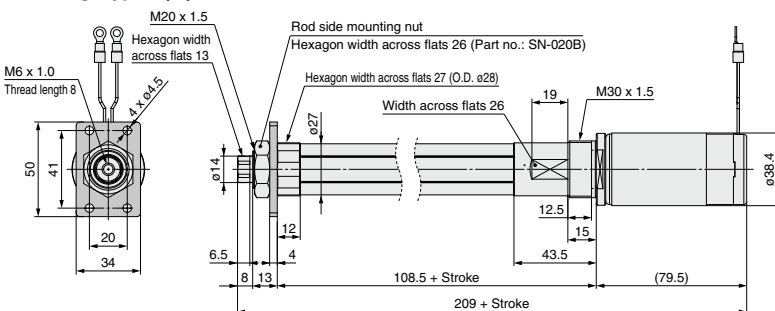

## Dimensions

### Rod trunnion type/L(D)ZBU3□

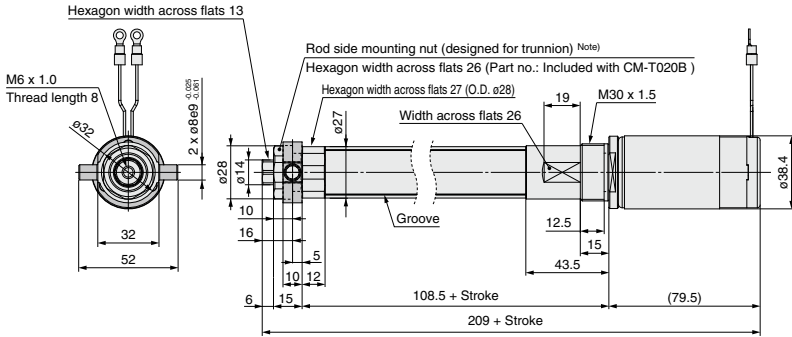

Note) The trunnion cannot be mounted using the rod side mounting nuts of other mounting types.

## ⚠ Caution for using a trunnion bracket

In the event of mounting a trunnion bracket, fix it to the position illustrated below before using.

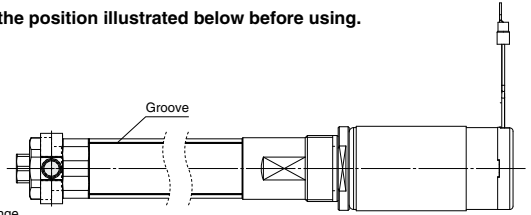
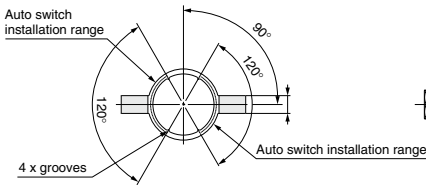

\* Conditions for using a trunnion bracket are as follows:

- Maximum stroke: 150 mm
- Thread lead L (lead 2 mm) only

LEF
LEJ
LEL
LEM
LEY
LES
LEPY
LEPS
LER
LEH
LEY
-X5
11-
LEFS
11-
LEJS
25A-
LEC□
LEC
S□
LEC
SS-T
LEC
Y□
Motor-
less
LAT
LZ□
LC3F2

# LZB Series

## Dimensions Note) Grounding must be performed.

### L(D)ZBB5□

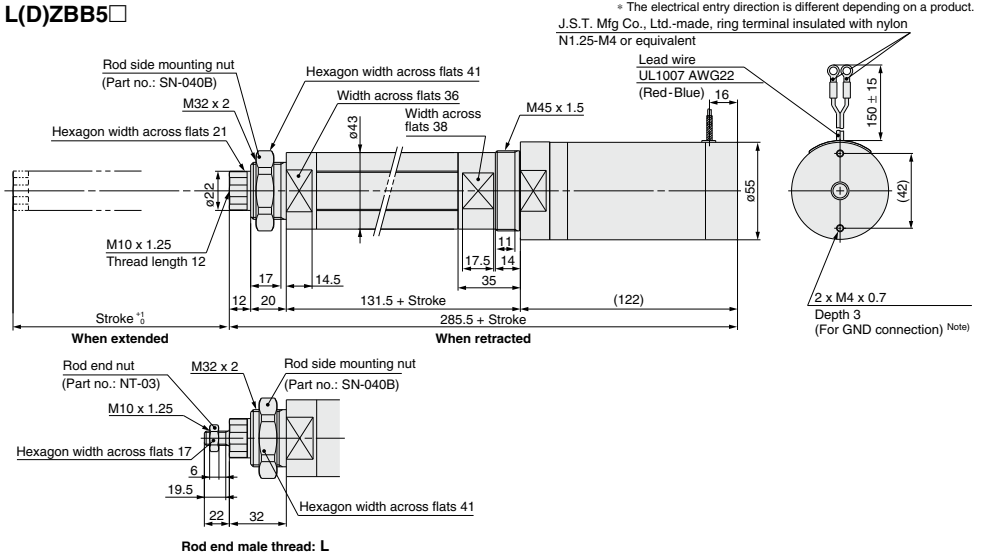

### Axial foot type/L(D)ZBL5□

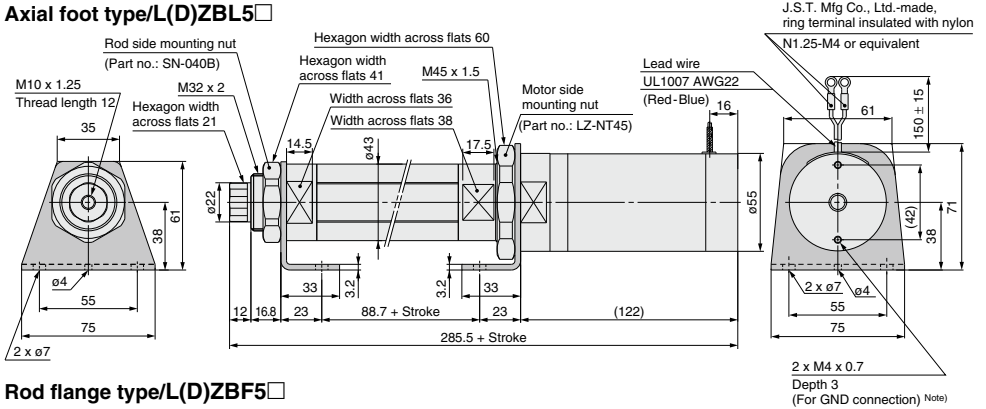

### Rod flange type/L(D)ZBF5□

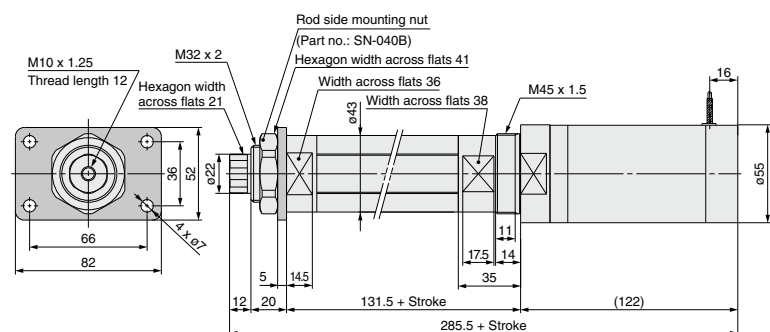



## Dimensions

### Rod trunnion type/L(D)ZBU5□

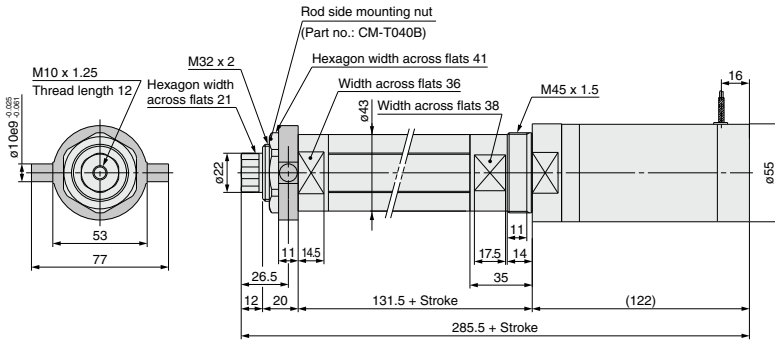

## ⚠ Caution for using a trunnion bracket

In the event of mounting a trunnion bracket, fix it to the position illustrated below before using.

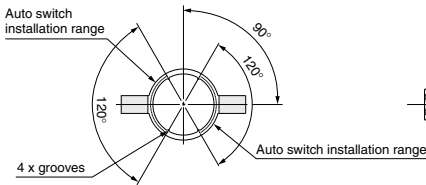

\* Conditions for using a trunnion bracket are as follows:

- Maximum stroke: 150 mm
- Thread lead L (lead 2 mm) only

LEF
LEJ
LEL
LEM
LEY
LES
LEPY
LEPS
LER
LEH
LEY
-X5
11-
LEFS
11-
LEJS
25A-
LEC□
LEC
S□
LEC
SS-T
LEC
Y□
Motor-
less
LAT
LZ□
LC3F2

# Electric Cylinder LZC Series



## How to Order

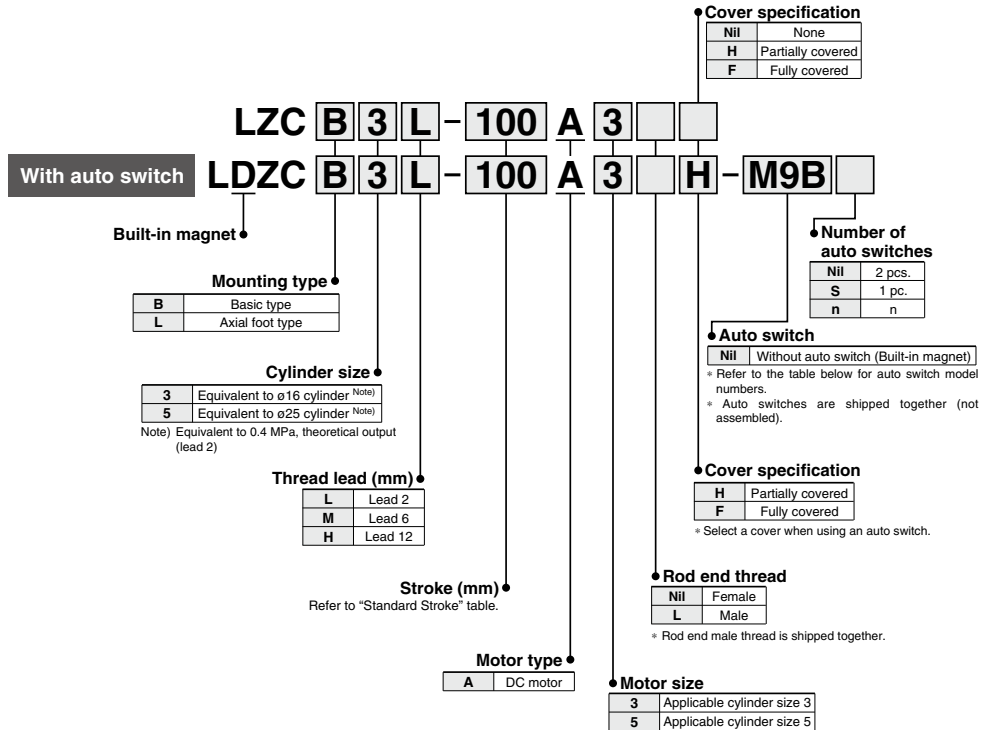

### Standard Stroke

Cylinder size	Standard stroke (mm) *
3, 5	25, 40, 50, 100, 200

\* Other intermediate strokes can be manufactured upon receipt of order.  
(Maximum manufacturable stroke: 200 mm)

### Applicable Auto Switches

For detailed auto switch specifications, refer to page 944.

Type	Special function	Electrical entry	Indicator light	Wiring (Output)	Load voltage		Auto switch model	Lead wire length (m) *				Pre-wired connector	Applicable load	
					DC	AC		0.5 (Nil)	1 (M)	3 (L)	5 (Z)		IC circuit	Relay PLC
Solid state switch	—	Grommet	Yes	3-wire (NPN)	24 V	5 V	—	●	●	●	○	○		
				3-wire (PNP)		12 V		●	●	○	○			
				2-wire		12 V		●	●	○	○			

\* Lead wire length symbols: 0.5 m ..... Nil (Example) M9B  
1 m ..... M M9BM  
3 m ..... L M9BL  
5 m ..... Z M9BZ

\* Solid state auto switches marked "○" are produced upon receipt of order.

**Specifications**



Model		L□ZC□3L	L□ZC□3M	L□ZC□3H	L□ZC□5L	L□ZC□5M	L□ZC□5H
Size		3 (Equivalent to ø16 cylinder) <sup>Note 1)</sup>			5 (Equivalent to ø25 cylinder) <sup>Note 1)</sup>		
Lead screw	Thread diameter	ø8			ø12		
	Lead (mm)	2	6	12	2	6	12
Rated speed with no load (mm/s) <sup>Note 2)</sup>		33 or more	100 or more	200 or more	33 or more	100 or more	200 or more
Rated thrust (N) <sup>Note 3)</sup>		80 or more	43 or more	24 or more	196 or more	117 or more	72 or more
Stroke (mm)		25, 40, 50, 100, 200					
Main body (kg) <sup>*</sup>		0.72 + (0.03/50 stroke)			1.72 + (0.16/50 stroke)		
Lateral load for rod end (at maximum stroke) (kg)		0.1			0.24		
Operating ambient temperature (°C)		5 to 40 (No condensation)					
Allowable tolerance of stroke		+1 0					
Motor		DC motor					
Applicable directional control driver model		LC3F212-5A3□			LC3F212-5A5□		
Applicable auto switch model		D-M9N, M9P, M9B					

Note 1) Equivalent to 0.4 MPa, theoretical output (lead 2)

Note 2) In the table speeds are shown without a load, as rated speed, and thrusts are shown as rated thrust based on the pressure force.

Note 3) Speed will vary as they are affected by a load. Refer to page 927 for model selection.

\* Refer to page 939 for mounting bracket weight.

**Allowable Lateral Load for Rod End**

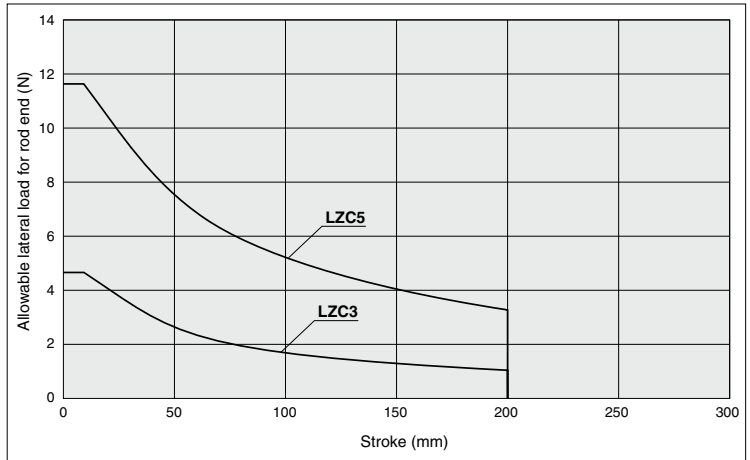

- LEF
- LEJ
- LEL
- LEM
- LEY
- LES
- LEPY
- LEPS
- LER
- LEH
- LEY-X5
- 11-LEFS
- 11-LEJS
- 25A-
- LEC□
- LEC S□
- LEC SS-T
- LEC Y□
- Motor-less
- LAT
- LZ□
- LC3F2

# LZC Series

## Dimensions Note) Grounding must be performed.

### L(D)ZCB3□

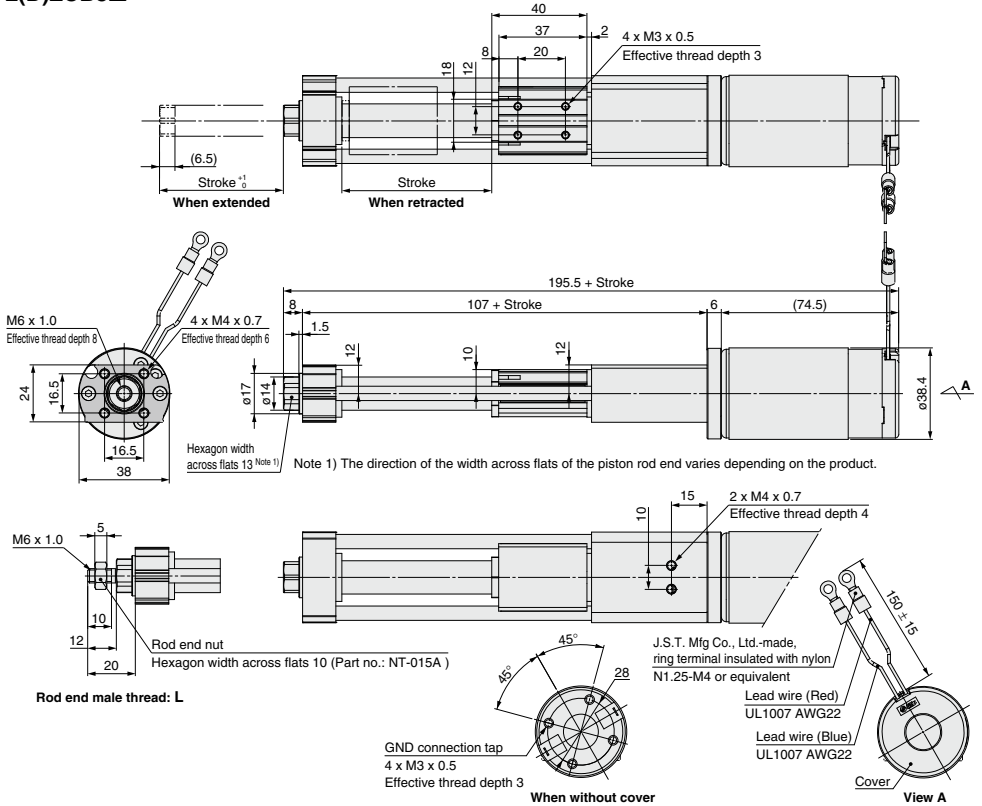

### Cover specification

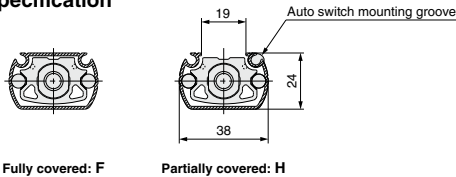

### Axial foot type: L

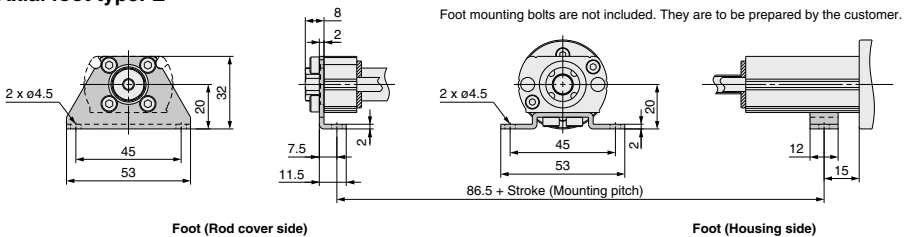

## Dimensions Note) Grounding must be performed.

### L(D)ZCB5□

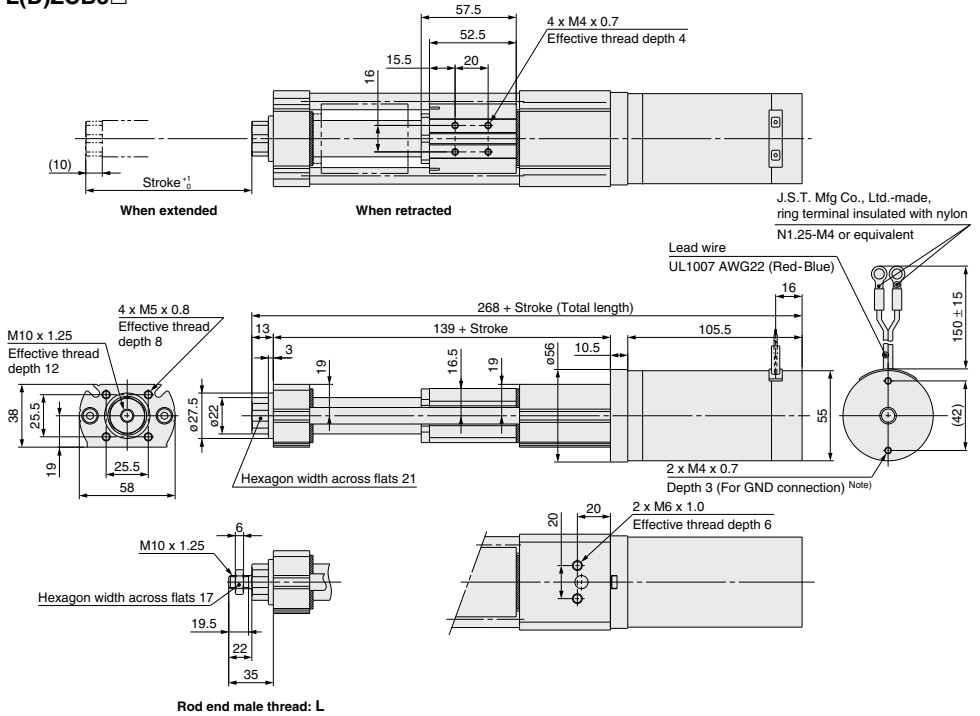

### Cover specification

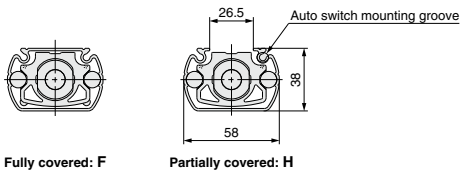

### Axial foot type: L

Foot mounting bolts are not included. They are to be prepared by the customer.

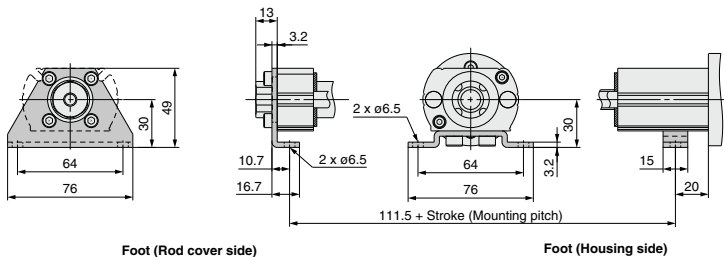

LEF
LEJ
LEL
LEM
LEY
LES
LEPY LEPS
LER
LEH
LEY -X5
11-LEFS
11-LEJS
25A-
LEC□
LEC S□
LEC SS-T
LEC Y□
Motor-less
LAT
LZ□
LC3F2

# LZB/LZC Series

## LZB/C Vertical Application Specifications

Some of the LZ series can be used in vertical applications.  
However, please check before using vertically.

Never apply a force exceeding the prescribed force.  
When a force exceeding the transfer thrust is applied, the cylinder and directional control driver (LC3F2) may be damaged.

### Model which can be used vertically

- L(D)ZB□3L-□A3□-□□
- L(D)ZC□3L-□A3□□-□□
- L(D)ZB□5L-□A5□-□□
- L(D)ZC□5L-□A5□□-□□

### Specifications

Model	L(D)ZB□3L	L(D)ZC□3L	L(D)ZB□5L	L(D)ZC□5L
Speed (mm/s)	P.927 Refer to the graph on speed – thrust.			
Transfer thrust (Vertically) (N)	40		100	
Holding force* (N)	40		100	
Standard stroke (mm)	25, 40, 50, 100, 200			
Operating ambient temperature (°C)	5 to 40 (No condensation)			
Motor	DC motor			
Applicable directional control driver model	LC3F212-5A3□		LC3F212-5A5□	
Applicable auto switch model	D-M9N, D-M9P, D-M9B			

\* Holding force

Holding force means the force which cannot be dropped even if a load should be applied vertically when a cylinder is stopped.  
Therefore, for example, holding is not possible when turning off the power supply once a cylinder has been activated.  
Additionally, a load may be dropped due to external impacts or vibrations.

## Accessories

### LZB

Accessory	Description
With auto switch	Switch mounting band, switch mounting bracket (one included per one switch)
Foot type	Rod side foot bracket, motor side foot bracket Rod side mounting nut, motor side mounting nut
Flange type	Flange bracket, rod side mounting nut
Trunnion type	Trunnion bracket Rod side mounting nut (designed for trunnion)

### LZC

Accessory	Description
Foot type	Rod side foot bracket, motor side foot bracket Foot bracket mounting bolts (6)

## Accessory Bracket

### Mounting nut

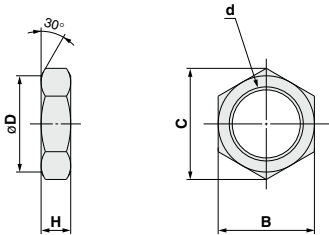

### Rod end nut

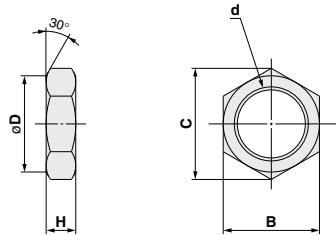

Name	Part no.	Applicable series	B	C	D	d	H
Rod side mounting nut	<b>SN-020B</b>	LZB3	26	30	25.5	M20 x 1.5	8
Motor side mounting nut	<b>LZ-NT30</b>	LZB3	38	42	38	M30 x 1.5	10
Rod side mounting nut	<b>SN-040B</b>	LZB5	41	47.3	40.5	M32 x 2.0	10
Motor side mounting nut	<b>LZ-NT45</b>	LZB5	60	64	60	M45 x 1.5	10

Part no.	Applicable series	B	C	D	d	H
<b>NT-015A</b>	LZ□3	10	11.5	9.8	M6 x 1.0	5
<b>NT-03</b>	LZ□5	17	19.6	16.5	M10 x 1.25	6

## Mounting Bracket/Part No.

Series	LZB3	LZB5
Rod side foot	LZB-LR3 (64 g)	LZB-LR5 (112 g)
Motor side foot	LZB-LM3 (64 g)	LZB-LM5 (126 g)
Flange	LZB-F3 (40 g)	LZB-F5 (120 g)
Rod side trunnion	CM-T020B*1 (40 g)	CM-T040B*1 (100 g)

Series	LZC3	LZC5
Rod side foot	LZC-LR3 (21 g)	LZC-LR5 (71 g)
Motor side foot	LZC-LM3 (10 g)	LZC-LM5 (27 g)

( ): Weight for bracket  
Note) Bracket mounting nuts are not included. Please prepare separately.

( ): Weight for bracket  
Note) Bracket mounting nuts are not included. Please purchase mounting nuts matched to each bracket separately.

\*1 The trunnion rod side mounting nuts (designed for the trunnion type) are included with the mounting bracket.

LEF  
LEJ  
LEL  
LEM  
LEY  
LES  
LEPY  
LEPS  
LER  
LEH  
LEY  
-X5  
11-  
LEFS  
11-  
LEJS  
25A-  
LEC□  
LEC  
□  
LEC  
SS-T  
LEC  
Y□  
Motor-  
less  
LAT  
LZ□  
LC3F2

# Auto Switches Mounting

## Auto Switch Hysteresis

Hysteresis is the distance between the position at which slider movement operates an auto switch to the position at which reverse movement turns the switch off. This hysteresis is included in part of the operating range (one side).

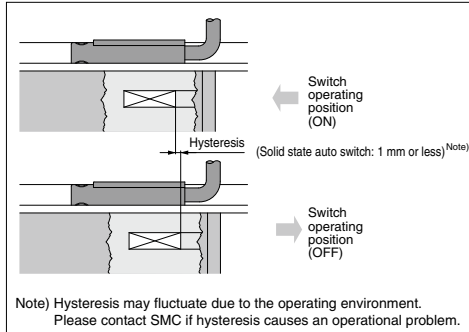



**Auto Switch Proper Mounting Position (Detection at Stroke End) and It's Mounting Height**

Solid state auto switch

D-M9□

LDZB

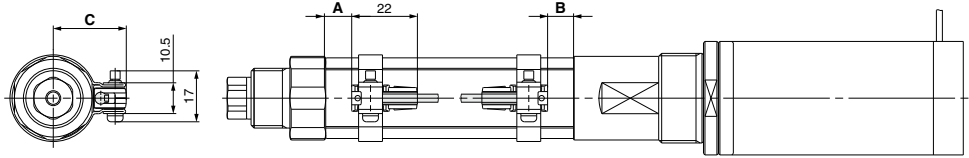

**Auto Switch Mounting Position/Height**

Model	A	B	C
LDZB□3	20	19	24
LDZB□5	33	33	32

**Operating Range of Auto Switch \***

Model	A
LDZB□3	3
LDZB□5	5

\* The operating range is a guide including hysteresis, but is not guaranteed. There may be substantial variation depending on the surrounding environment (assuming approximately ±30% dispersion).

**Minimum Stroke for Auto Switch Mounting**

Model	1 pc.	2 pcs. (Different sides)	2 pcs. (Same sides)
LDZB□3	10	15	45
LDZB□5	10	15	45

LDZC

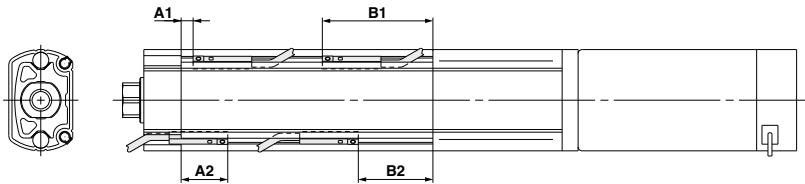

**Auto Switch Mounting Position for Stroke End Detection**

Model	A1	A2	B1	B2
LDZC□3	4.5	17.5	41.5	28
LDZC□5	7	57	20	44

**Operating Range of Auto Switch \***

Model	A
LDZC□3	2
LDZC□5	2

\* The operating range is a guide including hysteresis, but is not guaranteed. There may be substantial variation depending on the surrounding environment (assuming approximately ±30% dispersion).

**Minimum Stroke for Auto Switch Mounting**

Model	1 pc.	2 pcs.
LDZC□3	5	10
LDZC□5	5	10

- LEF
- LEJ
- LEL
- LEM
- LEY
- LES
- LEPY
- LEPS
- LER
- LEH
- LEY-X5
- 11-LEFS
- 11-LEJS
- 25A-
- LEC□
- LEC S□
- LEC SS-T
- LEC Y□
- Motor-less
- LAT
- LZ□
- LC3F2

## Mounting and Moving Auto Switches (Series LDZB Only)

### ⚠ Caution

1. Tighten the screw under the specified torque when mounting the auto switch.
2. Set the auto switch mounting band perpendicularly to cylinder tube.

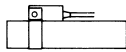

Correctly attached

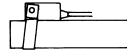

Incorrectly attached

### Mounting the Auto Switch

1. Attach a switch bracket to the switch holder.  
(Fit the switch bracket to the switch holder.)
2. Mount an auto switch mounting band to the cylinder tube.
3. Set the switch holder (1.) between the reinforcing plates of the band mounted to the cylinder.
4. Insert an auto switch mounting screw in the hole of the reinforcing plate through the auto switch holder, and thread it into the other plate. Tighten the screw temporarily.
5. Remove the set screw attached to the auto switch.
6. Attach a switch spacer to the auto switch.
7. Insert the auto switch with the switch spacer from the back of the switch holder.  
(Insert the auto switch with an angle of approximately 10 to 15°. See figure 1.)
8. To secure the auto switch, tighten the switch mounting screw with the specified torque (0.8 N·m to 1.0 N·m).

### Adjusting the Auto Switch Position

1. Unloosen the auto switch mounting screw 3 turns to adjust the auto switch set position.
2. Tighten the auto switch mounting screw as described above (8.) after adjustment.

### Removing the Auto Switch

1. Remove the auto switch mounting screw from the switch holder.
2. Move the auto switch back towards the position where it stops at the lead wire side.
3. Hold up the lead wire side of the auto switch at the angle of around 45°.
4. Maintain the angle, and pull back the auto switch obliquely at the same angle.

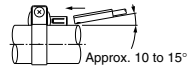
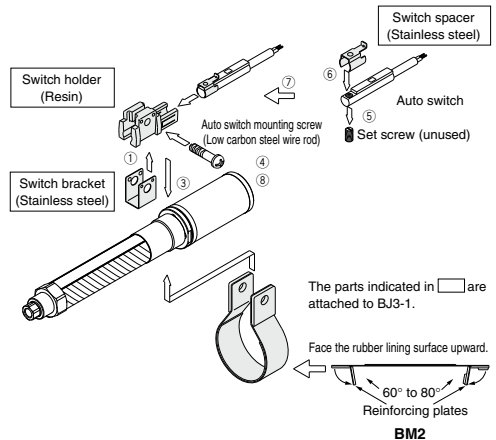

Figure 1. Auto switch insert angle



### Auto Switch Mounting Bracket/Part No.

Applicable series	Mounting bracket	Mounting band
LDZB□3	BJ3-1	BM2-025
LDZB□5	( Switch holder Switch spacer Switch bracket )	LZB5-SB

Order one auto switch mounting bracket and one auto switch mounting band per one auto switch.

# Prior to Use

## Auto Switch Connection and Example

### Sink Input Specifications

#### 3-wire, NPN

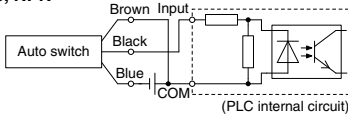

#### 2-wire

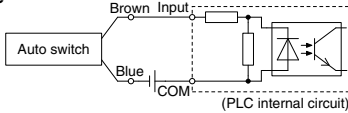

### Source Input Specifications

#### 3-wire, PNP

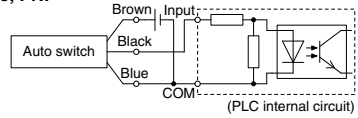

#### 2-wire

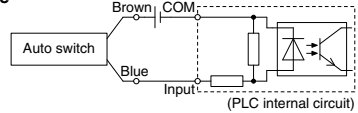

Connect according to the applicable PLC input specifications, as the connection method will vary depending on the PLC input specifications.

### Example of AND (Series) and OR (Parallel) Connection

\* When using solid state auto switches, ensure the application is set up so the signals for the first 50 ms are invalid.

#### 3-wire AND connection for NPN output (Using relays)

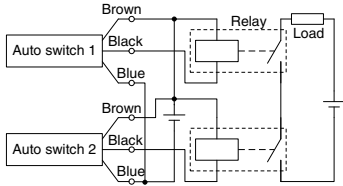

#### (Performed with auto switches only)

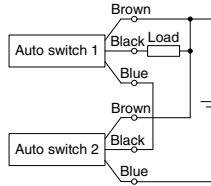

#### 3-wire OR connection for NPN output

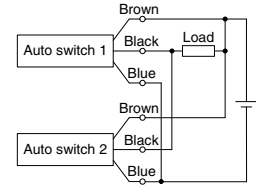

#### 3-wire AND connection for PNP output (Using relays)

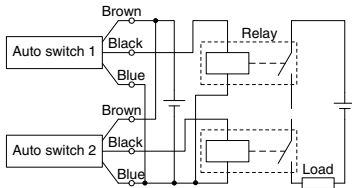

#### (Performed with auto switches only)

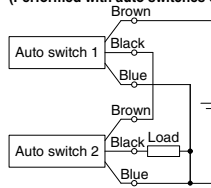

#### 3-wire OR connection for PNP output

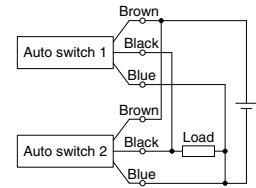

#### 2-wire AND connection

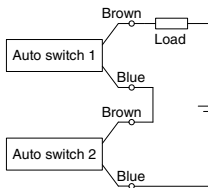

When two auto switches are connected in series, a load may malfunction because the load voltage will decline when in the ON state. The indicator lights will light up when both of the auto switches are in the ON state. Auto switches with load voltage less than 20V cannot be used.

Load voltage at ON = Power supply voltage – Residual voltage x 2 pcs.  
= 24 V – 4 V x 2 pcs.  
= 16 V

Example: Power supply is 24 VDC  
Internal voltage drop in auto switch is 4 V.

#### 2-wire OR connection

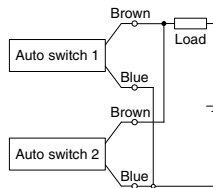

(Solid state)  
When two auto switches are connected in parallel, malfunction may occur because the load voltage will increase when in the OFF state.

(Reed)  
Because there is no current leakage, the load voltage will not increase when turned OFF. However, depending on the number of auto switches in the ON state, the indicator lights may sometimes grow dim or not light up, due to the dispersion and reduction of the current flowing to the auto switches.

Load voltage at OFF = Leakage current x 2 pcs. x Load impedance  
= 1 mA x 2 pcs. x 3 kΩ  
= 6 V

Example: Load impedance is 3 kΩ.  
Leakage current from auto switch is 1 mA.

- LEF
- LEJ
- LEL
- LEM
- LEY
- LES
- LEPY
- LEPS
- LER
- LEH
- LEY
- X5
- 11-LEFS
- 11-LEJS
- 25A-
- LEC
- LEC
- LEC
- SS-T
- LEC
- Y
- Motor-less
- LAT
- LZ
- LC3F2

# Auto Switches

## Solid State Auto Switch



### Applicable Actuators



D-M9 (F9)	LZ Series
-----------	-----------

### Auto Switch Specifications

Auto switch model	D-M9N	D-M9P	D-M9B	D-F9G	D-F9H
<b>Contact</b>	N.O. (A contact)			N.C. (B contact)	
<b>Electrical entry direction</b>	In-line				
<b>Wiring type</b>	3-wire		2-wire	3-wire	
<b>Output type</b>	NPN	PNP	—	NPN	PNP
<b>Applicable load</b>	IC circuit, Relay, PLC		24 VDC relay, PLC	IC circuit, Relay, PLC	
<b>Power supply voltage</b>	5, 12, 24 VDC (4.5 to 28 V)		—	5, 12, 24 VDC (4.5 to 28 V)	
<b>Current consumption</b>	10 mA or less		—	10 mA or less	
<b>Load voltage</b>	28 VDC or less	—	24 VDC (10 to 28 VDC)	28 VDC or less	—
<b>Load current</b>	40 mA or less		2.5 to 40 mA	40 mA or less	80 mA or less
<b>Internal voltage drop</b>	0.8 V or less at 10 mA (2 V or less at 40 mA)		4 V or less	1.5 V or less (0.8 V or less at 10 mA load current)	0.8 V or less
<b>Leakage current</b>	100 $\mu$ A or less at 24 VDC		0.8 mA or less	100 $\mu$ A or less at 24 VDC	
<b>Indicator light</b>	Red LED illuminates when turned ON.			Red LED illuminates when turned OFF.	
<b>Standard</b>	CE marking				

● Lead wires — Oilproof heavy-duty vinyl cord:  $\phi$ 2.7 x 3.2 ellipse (D-M9□) $\phi$ 2.7 (D-F9□) $\phi$ 3.4 (D-Y7□), 3 cores (Brown, Black, Blue), 2 cores (Brown, Blue).

● Insulation resistance — Over 50 M $\Omega$  at 500 VDC Mega (between lead wire and case)

● Withstand voltage — 1000 VAC 1 minute (between lead wire and between case)

● Ambient temperature — -10 to 60°C ● Operating time — 1 ms or less ● Impact resistance — 1000 m/s<sup>2</sup>

\* For details, refer to Best Pneumatics No. 2-1.

With pre-wired connector is also available.



## LZB/LZC Series

# Specific Product Precautions

Be sure to read this before handling the products. For safety instructions as well as electric actuator and auto switch precautions, refer to the “Handling Precautions for SMC Products” and the “Operation Manual” on the SMC website: <https://www.smcworld.com>

### Caution

**1. Mount the auto switches at the center of the operating range.**

Check ON and OFF points before setting auto switches so that positions can be detected at the center of the operating range. If mounted at the end of the operating range, the signal detection will be unstable.

**2. Be aware of the environment temperature and thermal cycle.**

Operate auto switches and auto switch cylinders within the operating temperature range. The reliability of the auto switches may be adversely affected, especially, when they are exposed to thermal shock, severe temperature and humidity cycle etc.

**3. Be aware of the suitability of oil, chemicals etc.**

Resin and rubber materials are used for the auto switches and auto switch mounting brackets. Therefore, if there are chemicals such as oil or organic solvents in the environment, the resin and rubber materials may be adversely affected.

**4. During maintenance, securely tighten the switch mounting screws periodically.**

Use auto switch mounting brackets with the proper tightening torque. In addition, securely tighten the auto switch mounting screws periodically.

**5. Be careful not to pull or strain the lead wires.**

Be careful not to apply excess tensile force (over 10 N) to the auto switches. Also, adjust the position of the auto switches by sufficiently loosening the auto switch mounting screws (3 turns or more).

**6. Do not use the auto switches in environments with strong vibration and impact.**

Do not use the auto switches in environments where excess vibration and impact force outside of the specifications are applied.

**7. Be sure to use a switch spacer and a switch bracket.**

Confirm that a switch spacer is mounted to the end of the auto switch before fastening the auto switch. If the switch bracket is not mounted, the auto switch may move after installation.

LEF
LEJ
LEL
LEM
LEY
LES
LEPY
LEPS
LER
LEH
LEY
-X5
11-
LEFS
11-
LEJS
25A-
LEC□
LEC
S□
LEC
SS-T
LEC
Y□
Motor-
less
LAT
LZ□
LC3F2