

Intrinsically Safe Explosion-proof 5 Port Solenoid Valve

Can be used as a certified intrinsic safety type product only in Japan.

Ex ia IIC T5 (Certificate model number: DEK22.0071X)

This product has passed equipment certification.

When using this product, be sure to use a safety retainer which has passed testing based on the internationally recommended practices for explosion-protected electrical installations in general industries.

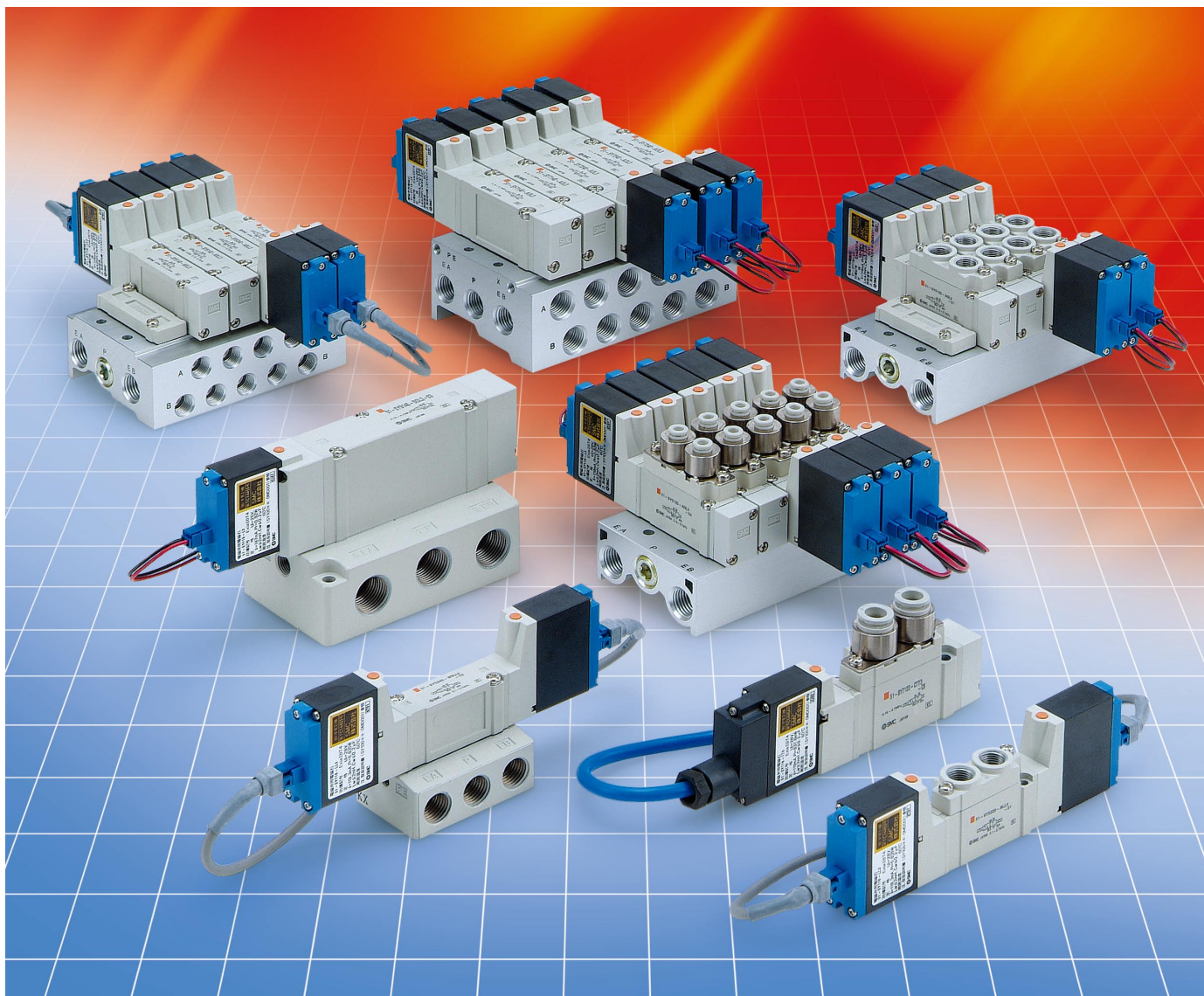

Series 51-SY5000/7000/9000

SMC
CAT.ES11-90B ©

Compact, High Flow

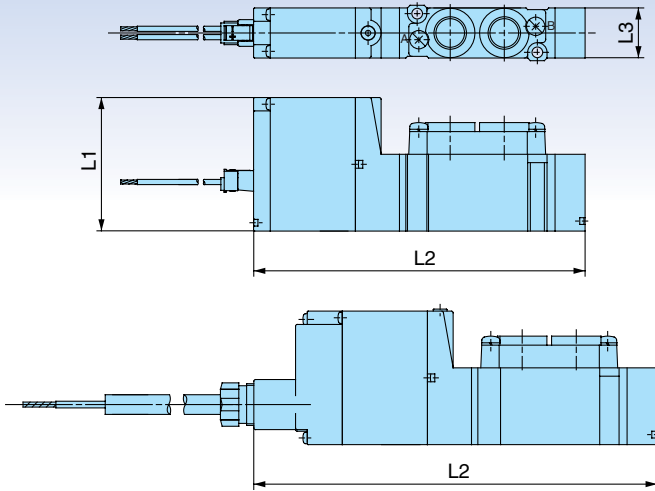

Dimensions

Dimension Model	L1	L2	L3
51-SY5120-L	40	104	15
51-SY5120-LL		120.8	
51-SY7120-L		118.2	18
51-SY7120-LL	135		
51-SY9120-L	42	148.3	23
51-SY9120-LL		165.1	
51-SY9120-TT			

Flow-rate Characteristics

Series		Flow-rate characteristics					
		1→4/2 (P→A/B)			4/2→5/3 (A/B→EA/EB)		
		C[dm ³ /(s·bar)]	b	Cv	C[dm ³ /(s·bar)]	b	Cv
Body ported	51-SY5□20	1.9	0.35	0.49	2.4	0.39	0.61
	51-SY7□20	4.1	0.23	0.93	3.3	0.33	0.81
	51-SY9□20	7.0	0.33	1.7	7.6	0.35	2.0
Base mounted	51-SY5□40	2.4	0.41	0.64	2.8	0.29	0.66
	51-SY7□40	4.1	0.41	1.1	4.1	0.29	1.0
	51-SY9□40	7.9	0.34	2.0	9.6	0.43	2.6

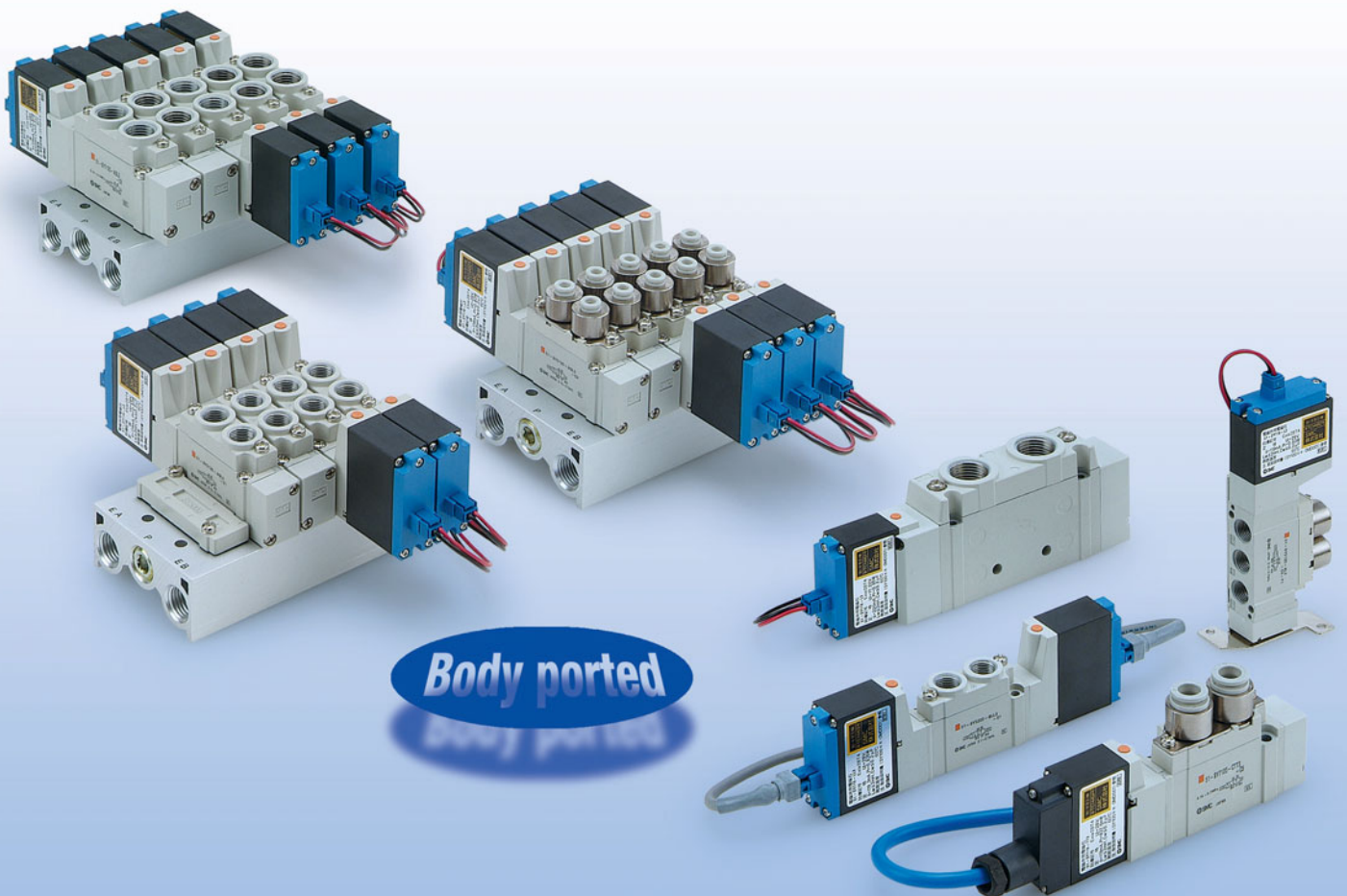

3 Types of Connectors

- Easily maintained by adapting connector for the lead wire (L- and LL-type)

- IP65 compliant (TT-type)

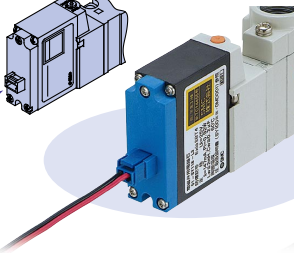
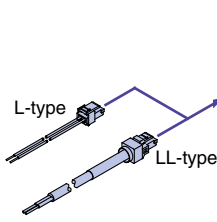

L-type plug connector (L-type)

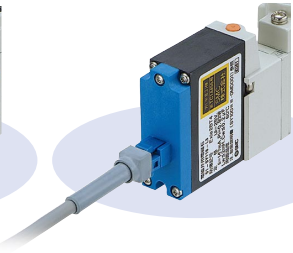

L-type plug connector with cover (LL-type)

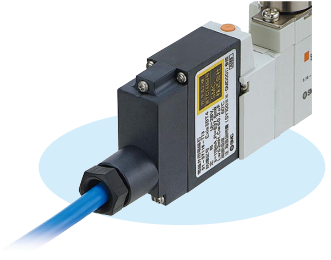

With IP65 compliant cable (TT-type)

2 Types of Barriers



Zener diode type

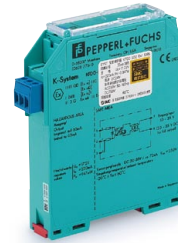

Insulating type

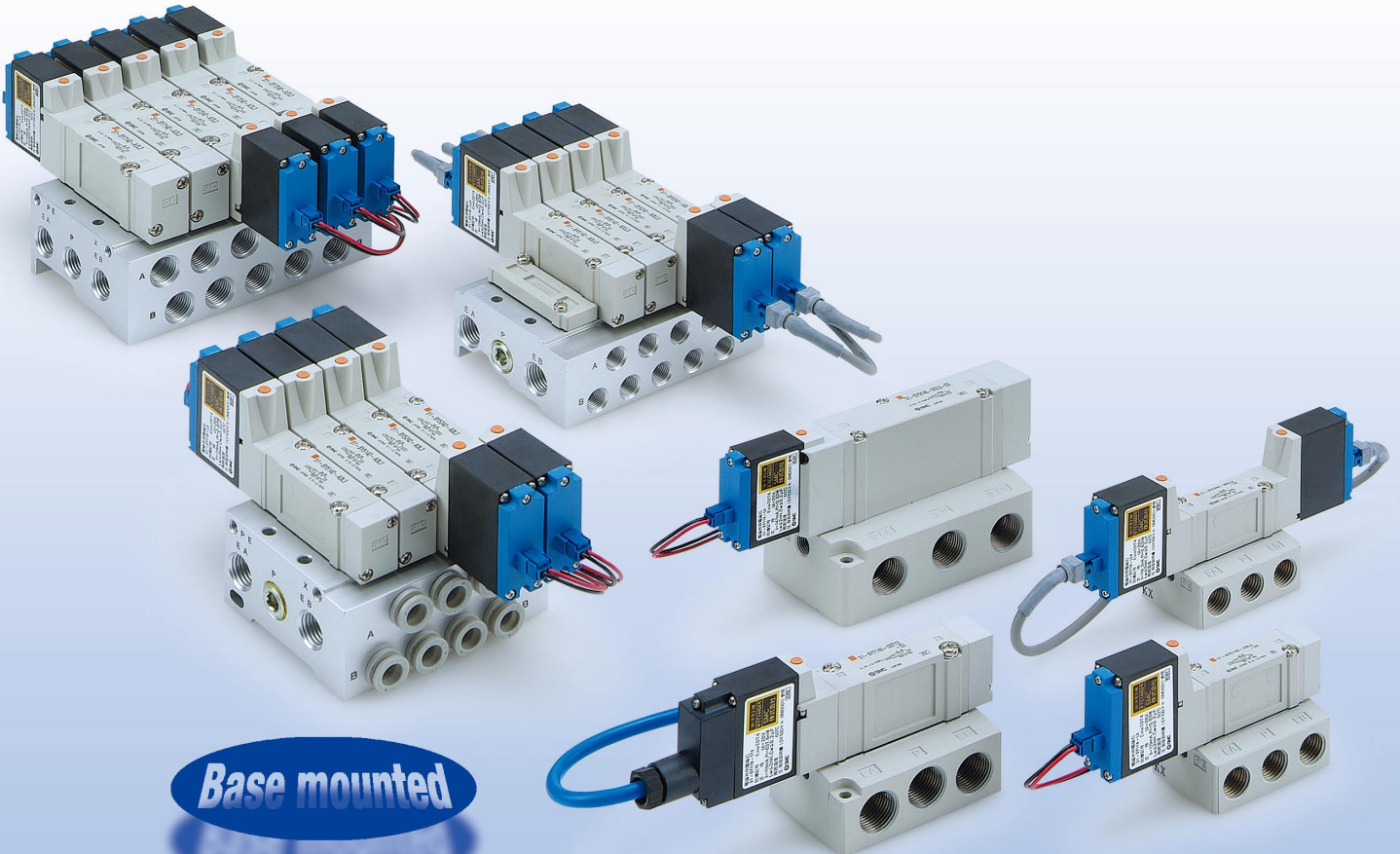

Base mounted



Intrinsically Safe Explosion-proof 5 Port Solenoid Valve Series 51-SY5000/7000/9000 Body Ported Single Unit

How to Order

51-SY 5 1 20-A LL 3 - 01 - -



Series

5	51-SY5000
7	51-SY7000
9	51-SY9000

Explosion-proof

51	Intrinsically safe explosion-proof structure
----	--

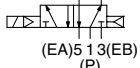
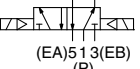
Type of actuation

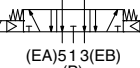
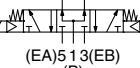
1	2-position single (A)4 2(B)  (EA)5 1 3(EB) (P)
2	2-position double (A)4 2(B)  (EA)5 1 3(EB) (P)
3 Note)	3-position closed center (A)4 2(B)  (EA)5 1 3(EB) (P)
4 Note)	3-position exhaust center (A)4 2(B)  (EA)5 1 3(EB) (P)
5 Note)	3-position pressure center (A)4 2(B)  (EA)5 1 3(EB) (P)

Note) 3-position type is not available for the 51-SY9000 series.

Barrier designation Note 1) Note 2)

Nil	Without barrier
A	Z728.H
F	KFD0-SD2-Ex1.1065

Note 1) Attached barrier type
Note 2) Contact Pepperl+Fuchs for details on the barrier specifications.

Thread type

Nil	Rc
F	G
N	NPT
T	NPTF

A, B port size
Thread piping

Symbol	Port size	Applicable series
01	1/8	51-SY5000
02	1/4	51-SY7000
02	1/4	51-SY9000
03	3/8	

One-touch fitting (Metric size) Note)

Symbol	Port size	Applicable series
C4	ø4 one-touch fitting	51-SY5000
C6	ø6 one-touch fitting	
C8	ø8 one-touch fitting	
C8	ø8 one-touch fitting	51-SY7000
C10	ø10 one-touch fitting	
C8	ø8 one-touch fitting	51-SY9000
C10	ø10 one-touch fitting	
C12	ø12 one-touch fitting	

Manual override

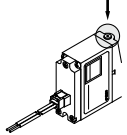
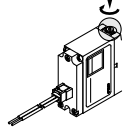
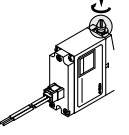
Nil: Non-locking push type 	D: Push-turn locking slotted type 	E: Push-turn locking lever type 
--	---	---

Lead wire length

Symbol	Lead wire length	Note
3	300 mm	—
6	600 mm	Maximum length for L-type
10	1000 mm	—
15	1500 mm	—
20	2000 mm	—
30	3000 mm	—
100	10000 mm	Semi-standard

Electrical entry

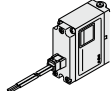
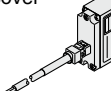
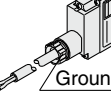
Symbol	Electrical entry
L	L-type plug connector 
LL	L-type plug connector with cover 
TT Note)	With IP65 compliant cable Ground nut 

Note) TT-type is connected to the terminal block.
Cables other than the connected one cannot be used.

Bracket

Nil: Without bracket
F1: With foot bracket (2-position single only)
F2: With side bracket

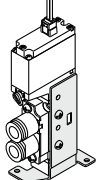
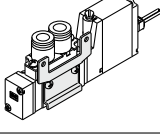



* The 51-SY9000 has no bracket.

Note) **Warning**
If a resin tube is used, take measures against static electricity.

Body Ported *Series 51-SY5000/7000/9000*

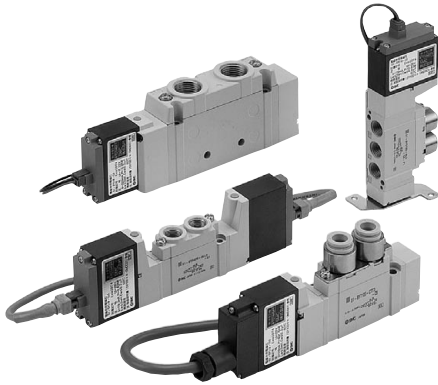
Specifications



Series		51-SY5000	51-SY7000	51-SY9000
Fluid		Air		
Internal pilot operating pressure range (MPa)	2-position single	0.15 to 0.7		
	2-position double	0.1 to 0.7		
	3-position	0.2 to 0.7		
Ambient and fluid temperature (°C)		-10 to 50 (No freezing)		
Max. operating frequency (Hz)	2-position single, double	1		
	3-position			
Manual override (Manual operation)		Non-locking push type, Push-turn locking slotted type, Push-turn locking lever type		
Pilot exhaust method		Main/Pilot valve common exhaust		
Lubrication		Not required		
Mounting orientation		Unrestricted		
Impact/Vibration resistance (m/s²) <small>Note 1)</small>		150/30		
Enclosure (Based on IEC60529)		IP30 (L-type), IP40 (LL-type), IP65 (TT-type)		
Electrical entry		L-type plug connector (L), L-type plug connector with cover (LL), With IP65 compliant cable (TT)		
Coil rated voltage		12 VDC		
Allowable voltage fluctuation		-10% to +10% of rated voltage		
Coil insulation type		Class B		
Power consumption		0.52 W (at rated voltage)		
Type of explosion-proof structure		Intrinsically safe explosion-proof structure (ia) <small>Note 2)</small>		
Applicable gas or ignition temperature of steam and explosion class		IIC T5		
Voltage to barrier		24 VDC <small>Note 3) Note 4)</small>		
Tolerant voltage fluctuation		-10% to +10% of rated voltage		

Note 1) Impact resistance: No malfunction occurred when it is tested in the axial direction and at the right angles to the main valve and armature in both energized and de-energized states every once for each condition. (Values at the initial period)

Vibration resistance: No malfunction occurred in a one-sweep test between 45 and 2000 Hz. Test was performed at both energized and de-energized states in the axial direction and at the right angles to the main valve and armature. (Values at the initial period)

Note 2) **Warning** Can not be used in a class-0 environment. Use in a class-2 or class-1 environment.

Note 3) **Caution** The valve and barrier have polarity. If voltage is supplied with wrong polarity, the barrier can not be used.

Note 4) **Caution** Voltage to the valve should be 10.8 VDC (minimum value).

Response Time

Note) Based on dynamic performance test, JIS B8419: 2010.
(Coil temperature: 20°C, barrier A, F at 24 VDC)

Type of actuation	Response time (ms) (at 0.5 MPa)		
	51-SY5000	51-SY7000	51-SY9000
2-position single	26 or less	38 or less	50 or less
2-position double	22 or less	30 or less	50 or less
3-position	38 or less	56 or less	—

Series 51-SY5000/7000/9000

Flow-rate Characteristics

Series 51-SY5000

Valve model	Type of actuation		Port size		Flow-rate characteristics <small>Note)</small>												
			1, 5, 3 (P, EA, EB)	4, 2 (A, B)	1→4/2 (P→A/B)			4/2→5/3 (A/B→EA/EB)									
					C(dm ³ /s·bar)	b	Cv	C(dm ³ /s·bar)	b	Cv							
51-SY5 □20-□ -01	2-position	Single	1/8	C4 ø4 one-touch fitting	1.9	0.35	0.49	2.4	0.39	0.61							
		Double															
	3-position	Closed center									1.7	0.43	0.45	1.8	0.35	0.46	
		Exhaust center															
		Pressure center															
		Exhaust center															
51-SY5 □20-□ -C4	2-position	Single			C6 ø6 one-touch fitting	0.75	0.43	0.20	0.85	0.64	0.30						
		Double															
	3-position	Closed center										0.74	0.40	0.19	0.84	0.57	0.28
		Exhaust center															
		Pressure center															
		Exhaust center															
51-SY5 □20-□ -C6	2-position	Single	C8 ø8 one-touch fitting	1.5		0.33	0.33	2.0	0.37	0.52							
		Double															
	3-position	Closed center									1.3	0.31	0.33	1.6	0.32	0.39	
		Exhaust center															
		Pressure center															
		Exhaust center															
51-SY5 □20-□ -C8	2-position	Single		C10 ø10 one-touch fitting	1.9	0.21	0.45	2.3	0.29	0.57							
		Double															
	3-position	Closed center									1.6	0.29	0.39	1.7	0.38	0.46	
		Exhaust center															
		Pressure center															
		Exhaust center															

 Note) []: Normal position

Series 51-SY9000

Valve model	Type of actuation		Port size		Flow-rate characteristics									
			1, 5, 3 (P, EA, EB)	4, 2 (A, B)	1→4/2 (P→A/B)			4/2→5/3 (A/B→EA/EB)						
					C(dm ³ /s·bar)	b	Cv	C(dm ³ /s·bar)	b	Cv				
51-SY9 □20-□ -02	2-position	Single	1/4	C8 ø8 one-touch fitting	7.0	0.33	1.7	7.6	0.35	2.0				
		Double												
51-SY9 □20-□ -03	2-position	Single			C10 ø10 one-touch fitting	8.0	0.29	1.9	8.0	0.33	2.0			
		Double												
51-SY9 □20-□ -C8	2-position	Single				C12 ø12 one-touch fitting	4.3	0.28	0.96	7.1	0.32	1.7		
		Double												
51-SY9 □20-□ -C10	2-position	Single					C10 ø10 one-touch fitting	6.1	0.28	1.4	7.9	0.33	1.9	
		Double												
51-SY9 □20-□ -C12	2-position	Double						C12 ø12 one-touch fitting	7.0	0.25	1.6	8.6	0.41	2.2
		Single												

Series 51-SY7000

Valve model	Type of actuation		Port size		Flow-rate characteristics <small>Note)</small>												
			1, 5, 3 (P, EA, EB)	4, 2 (A, B)	1→4/2 (P→A/B)			4/2→5/3 (A/B→EA/EB)									
					C(dm ³ /s·bar)	b	Cv	C(dm ³ /s·bar)	b	Cv							
51-SY7 □20-□ -02	2-position	Single	1/4	C8 ø8 one-touch fitting	4.1	0.23	0.93	3.3	0.33	0.81							
		Double															
	3-position	Closed center									2.9	0.31	0.70	2.4	0.38	0.63	
		Exhaust center															
		Pressure center															
		Exhaust center															
51-SY7 □20-□ -C8	2-position	Single			C10 ø10 one-touch fitting	3.2	0.26	0.77	3.2	0.37	0.82						
		Double															
	3-position	Closed center										2.6	0.24	0.63	2.4	0.31	0.62
		Exhaust center															
		Pressure center															
		Exhaust center															
51-SY7 □20-□ -C10	2-position	Single	C10 ø10 one-touch fitting	3.8		0.26	0.86	3.2	0.34	0.82							
		Double															
	3-position	Closed center									2.8	0.27	0.67	2.4	0.21	0.59	
		Exhaust center															
		Pressure center															
		Exhaust center															

 Note) []: Normal position

Construction

Series SY

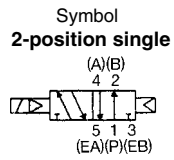

2-position single

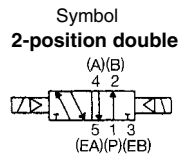
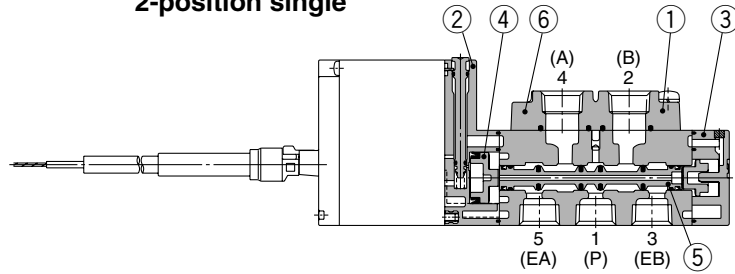

2-position double

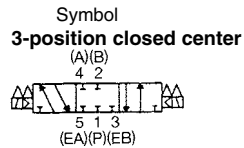
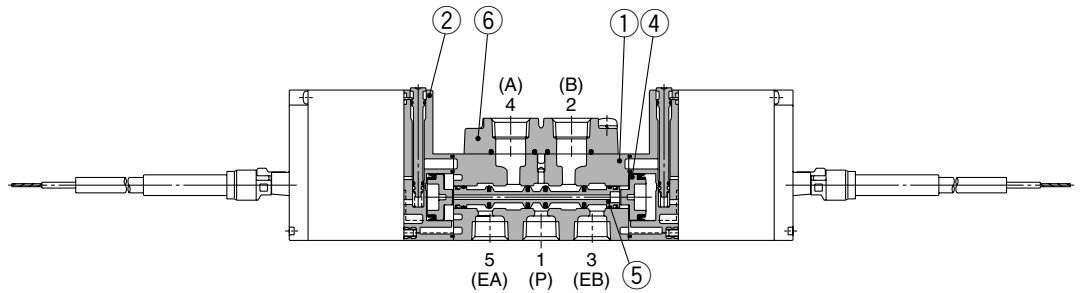

3-position closed center/exhaust center/pressure center

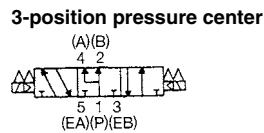
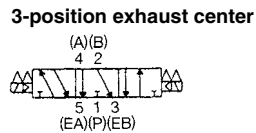
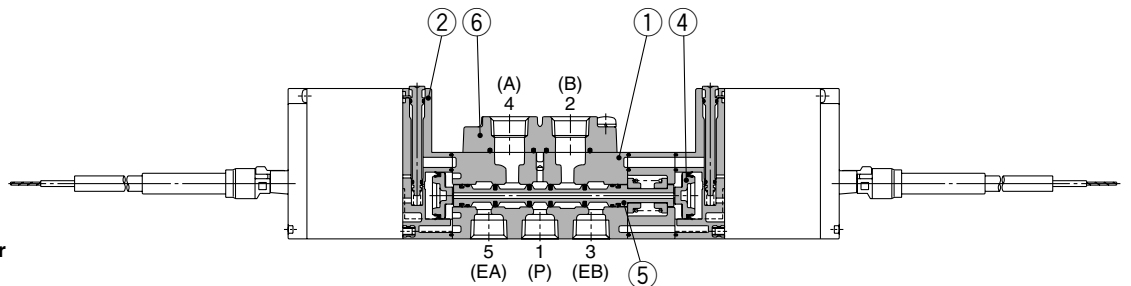

(This figure shows a closed center type.)

Component Parts

No.	Description	Material	Note
1	Body	Aluminum die-casted	White
2	Adapter plate	Resin	White (51-SY9000: Gray)
3	End plate	Resin	White
4	Piston	Resin	—
5	Spool valve assembly	Aluminum, HNBR	—

Replacement Parts

No.	Description	Part no.
6	Port block assembly	Refer to "How to Order Port Block Assembly" on page 5.

Bracket Assembly Part No.

Description	Part no.
Bracket (for F1)	SX ⁵ 000-16-2A (with mounting screw)
Bracket (for F2)	SX ⁵ 000-16-1A (with mounting screw)

* The 51-SY9000 has no bracket.

How to Change Port Block Assembly

If using body ported type, both A and B port sizes can be changed by replacing the port block assembly mounted on the body. When changing this block assembly, the correct screw torque must be achieved to avoid possible air leakage.

● 51-SY5000

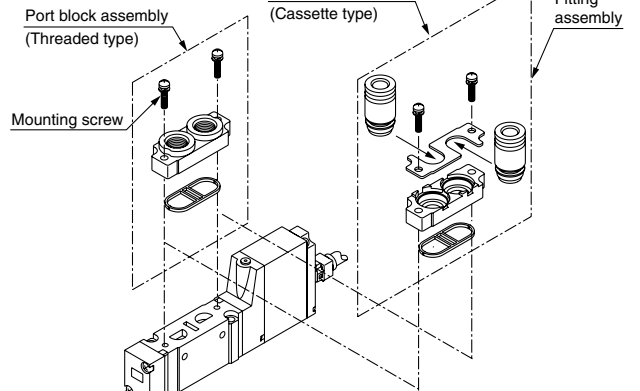

⚠ Caution

Mounting screw tightening torques

51-SY⁵000 (M3): 0.6 N·m
51-SY9000 (M4): 1.4 N·m

* Refer to "How to Order Port Block Assembly" on page 5 for part number.

Series 51-SY5000/7000/9000

How to Order Port Block Assembly

SY 000-6A-

• **Series**

5	51-SY5000
7	51-SY7000
9	51-SY9000

• **Thread type**

Nil	Rc
F	G
N	NPT
T	NPTF

• **A, B port size**

Thread piping

Symbol	Port size	Applicable series
01	1/8	51-SY5000
02	1/4	51-SY7000
02	1/4	51-SY9000
03	3/8	

One-touch fitting (Metric size)

Symbol	Port size	Applicable series
C4	ø4 one-touch fitting	51-SY5000
C6	ø6 one-touch fitting	
C8	ø8 one-touch fitting	
C8	ø8 one-touch fitting	51-SY7000
C10	ø10 one-touch fitting	
C8	ø8 one-touch fitting	51-SY9000
C10	ø10 one-touch fitting	
C12	ø12 one-touch fitting	

One-touch fitting (Inch size)

Symbol	Port size	Applicable series
N3	ø5/32" one-touch fitting	51-SY5000
N7	ø1/4" one-touch fitting	
N9	ø5/16" one-touch fitting	
N9	ø5/16" one-touch fitting	51-SY7000
N11	ø3/8" one-touch fitting	
N9	ø5/16" one-touch fitting	51-SY9000
N11	ø3/8" one-touch fitting	

* Only the fitting assembly replacement is also possible.

Metric size

Series	Port size	Part number
51-SY5000	ø4 one-touch fitting	VVQ1000-51A-C4
	ø6 one-touch fitting	VVQ1000-51A-C6
	ø8 one-touch fitting	VVQ1000-51A-C8
51-SY7000	ø8 one-touch fitting	VVQ2000-51A-C8
	ø10 one-touch fitting	VVQ2000-51A-C10
51-SY9000	ø8 one-touch fitting	VVQ4000-50B-C8
	ø10 one-touch fitting	VVQ4000-50B-C10
	ø12 one-touch fitting	VVQ4000-50B-C12

Inch size

Series	Port size	Part number
51-SY5000	ø5/32" one-touch fitting	VVQ1000-51A-N3
	ø1/4" one-touch fitting	VVQ1000-51A-N7
	ø5/16" one-touch fitting	VVQ1000-51A-N9
51-SY7000	ø5/16" one-touch fitting	VVQ2000-51A-N9
	ø3/8" one-touch fitting	VVQ2000-51A-N11
51-SY9000	ø5/16" one-touch fitting	VVQ4000-50B-N9
	ø3/8" one-touch fitting	VVQ4000-50B-N11

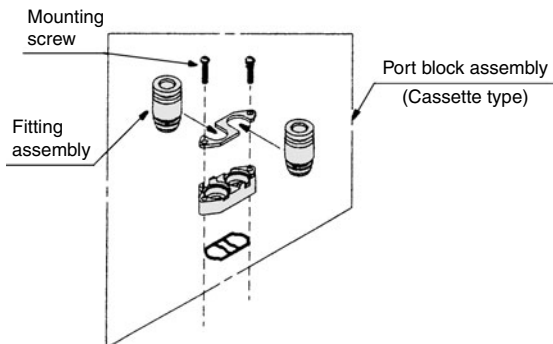

Warning If a resin tube is used, take measures against static electricity.

Dimensions: 51-SY5000

2-position single
L-type plug connector (L)
51-SY5120-□L□□-01□ (-F2)

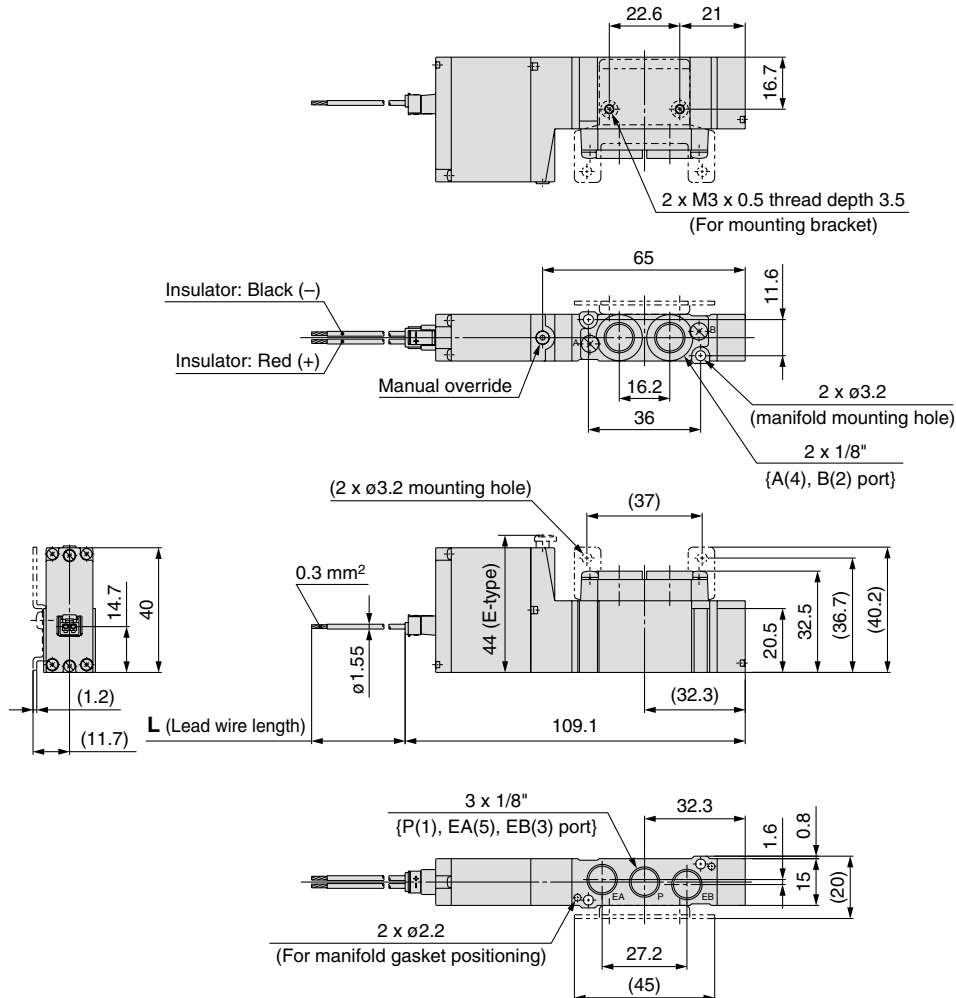

With foot bracket
51-SY5120-□L□□-01□-F1

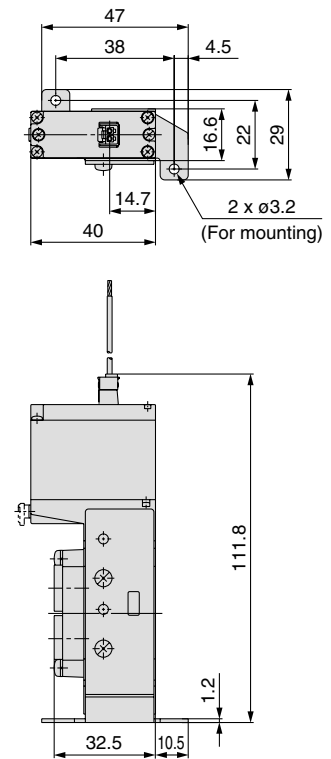

L-type plug connector with cover (LL)
51-SY5120-□LL□□-01□ (-F2)

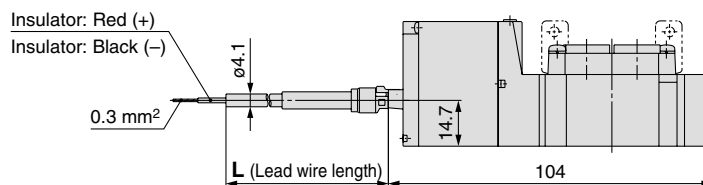

With IP65 compliant cable (TT)
51-SY5120-□TT□□-01□ (-F2)

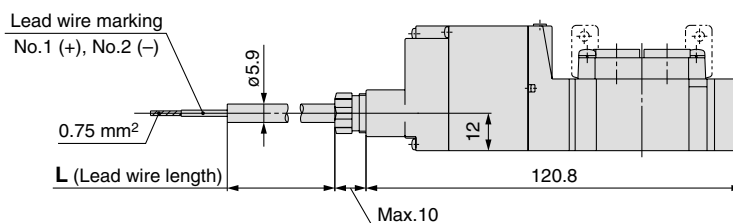

Series 51-SY5000/7000/9000

Dimensions: 51-SY5000

2-position double

L-type plug connector (L)

51-SY5220-□L□□-01□ (-F2)

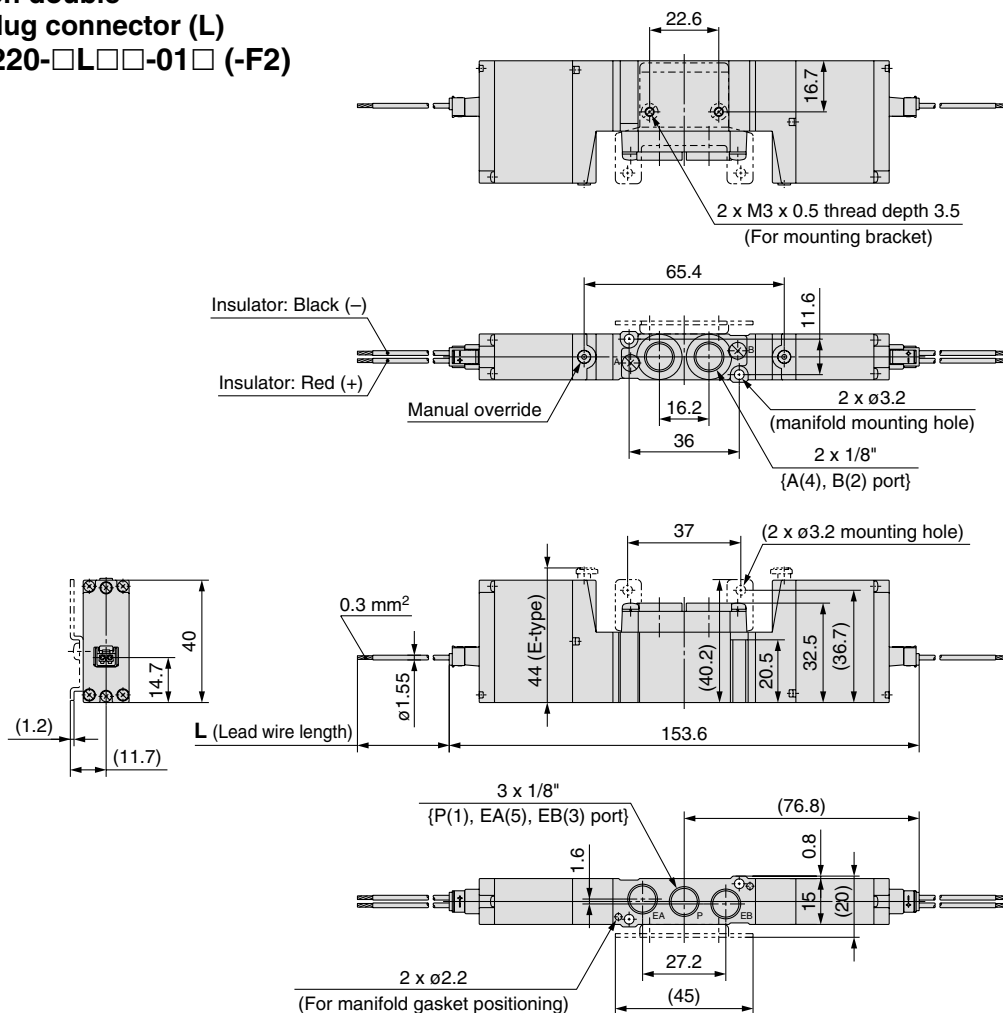

L-type plug connector with cover (LL)

51-SY5220-□LL□□-01□ (-F2)

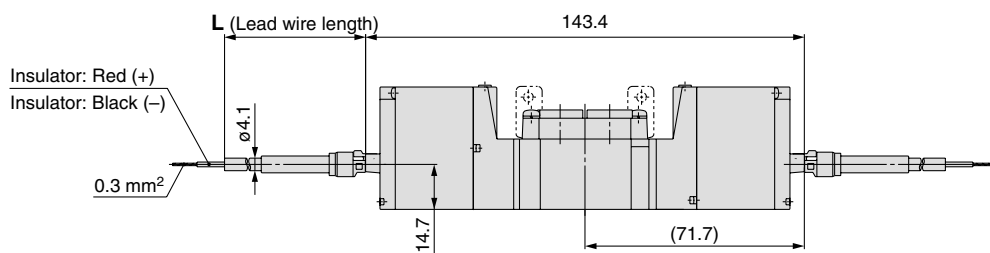

With IP65 compliant cable (TT)

51-SY5220-□TT□□-01□ (-F2)

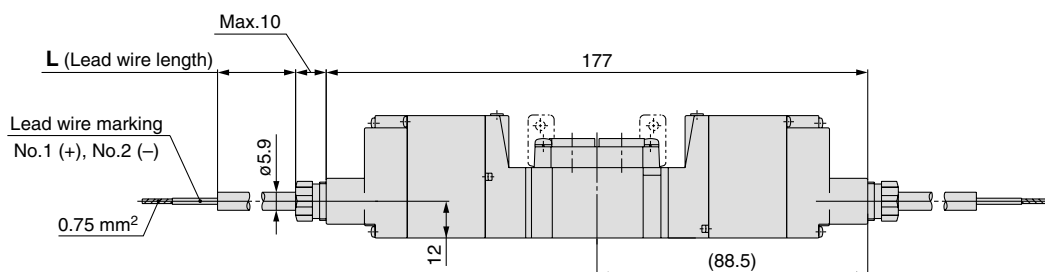

Dimensions: 51-SY5000

3-position closed center/exhaust center/pressure center

L-type plug connector (L)

51-SY5³/₄20-□L□□-01□ (-F2)

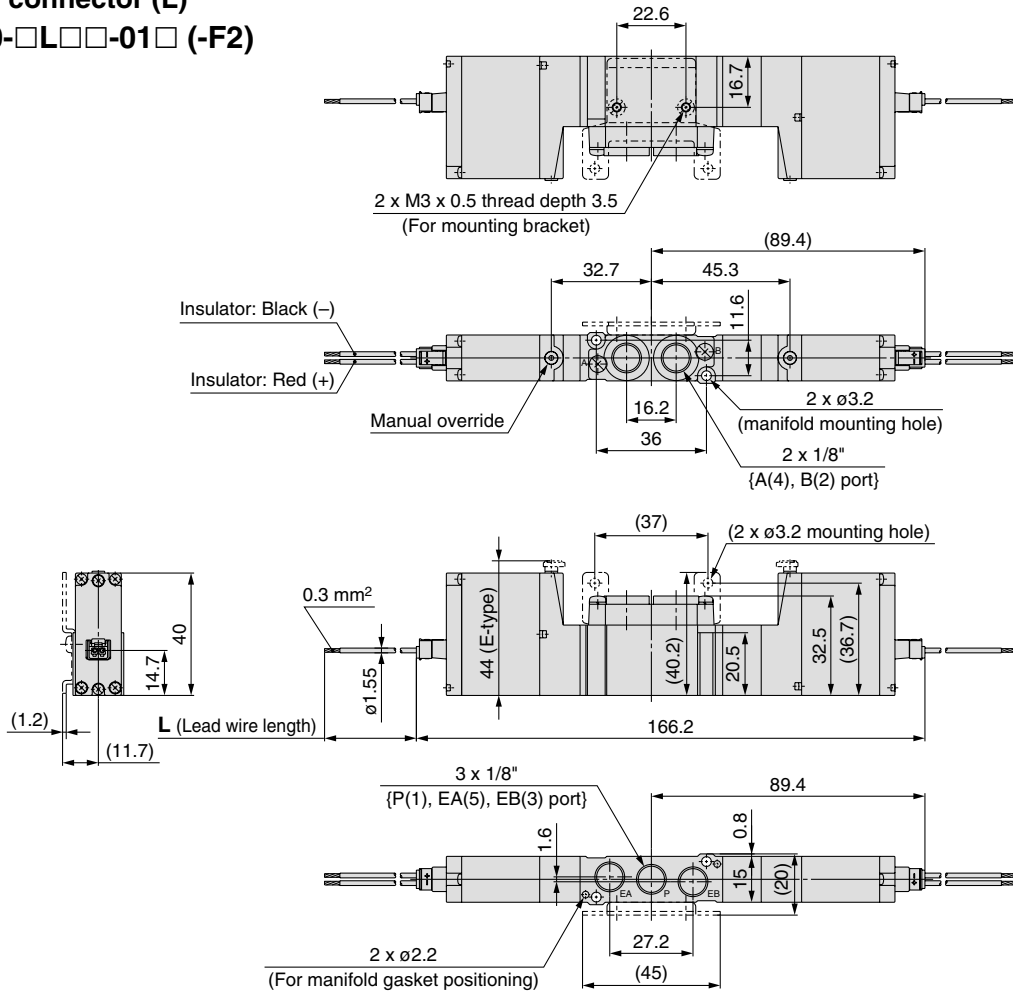

L-type plug connector with cover (LL)

51-SY5³/₄20-□LL□□-01□ (-F2)

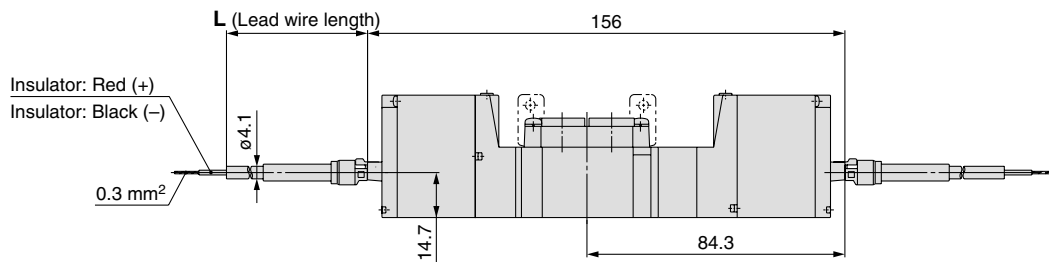

With IP65 compliant cable (TT)

51-SY5³/₄20-□TT□□-01□ (-F2)

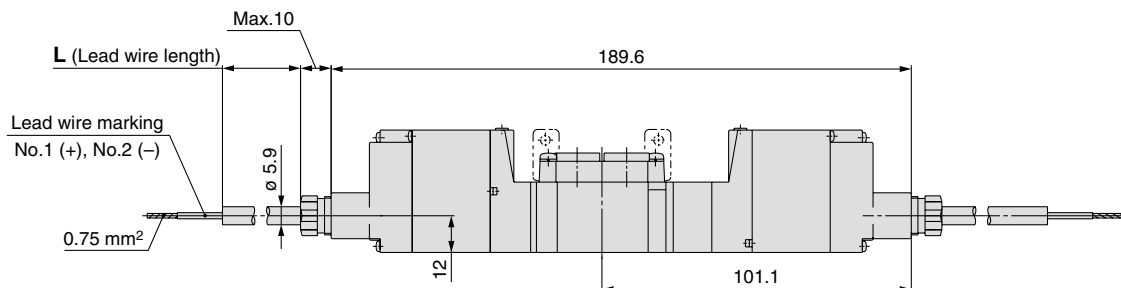

Series 51-SY5000/7000/9000

Dimensions: 51-SY7000

2-position single

L-type plug connector (L)

51-SY7120-□L□□-02□ (-F2)

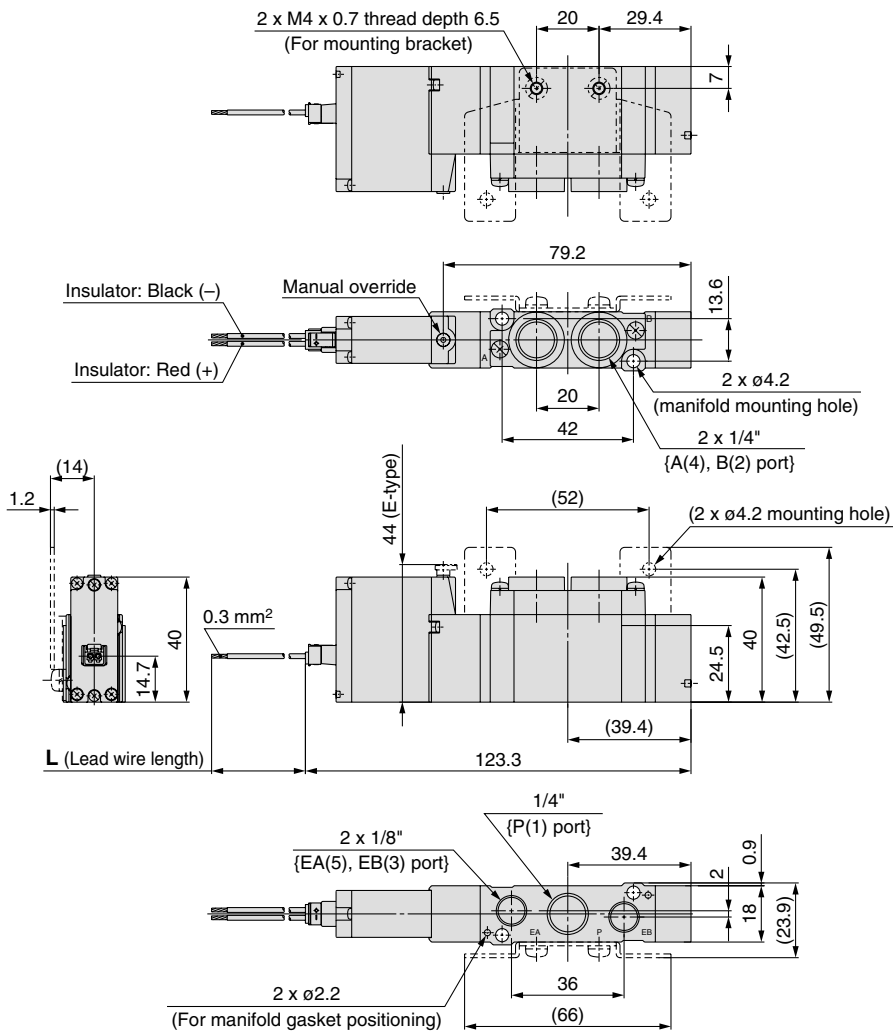

With foot bracket

51-SY7120-□L□□-02□-F1

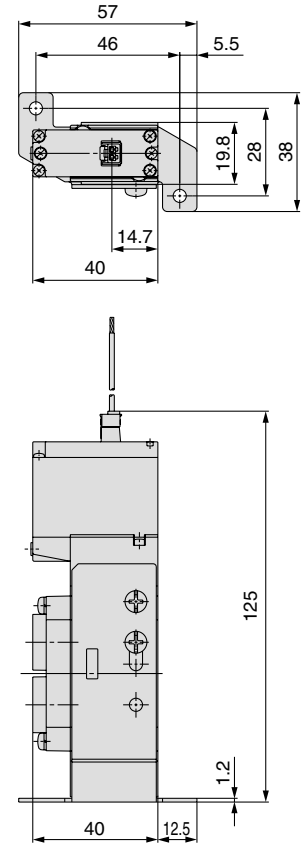

L-type plug connector with cover (LL)

51-SY7120-□LL□□-02□ (-F2)

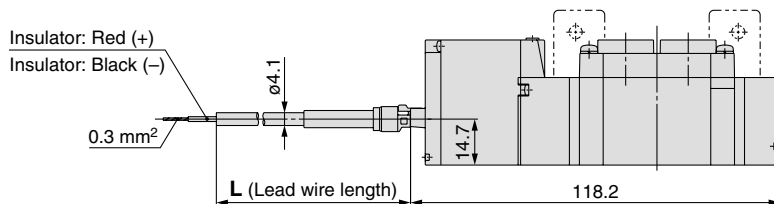

With IP65 compliant cable (TT)

51-SY7120-□TT□□-02□ (-F2)

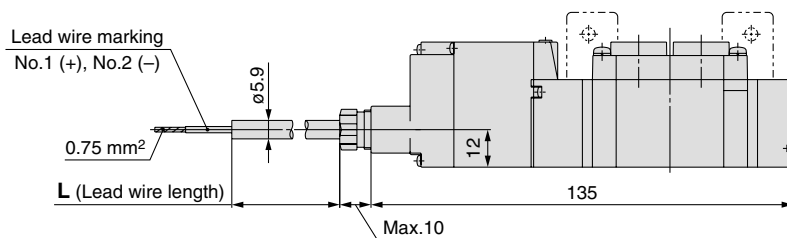

Dimensions: 51-SY7000

2-position double

L-type plug connector (L)

51-SY7220-□L□□-02□ (-F2)

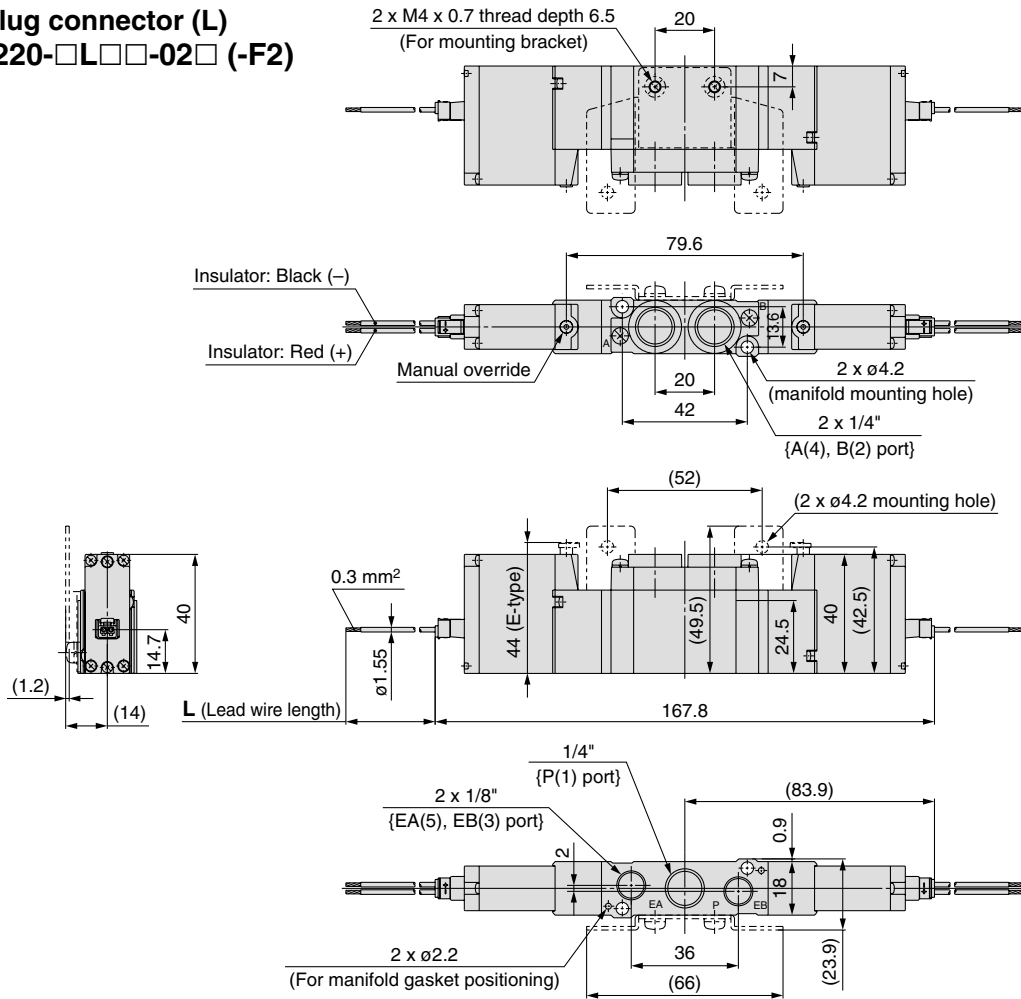

L-type plug connector with cover (LL)

51-SY7220-□LL□□-02□ (-F2)

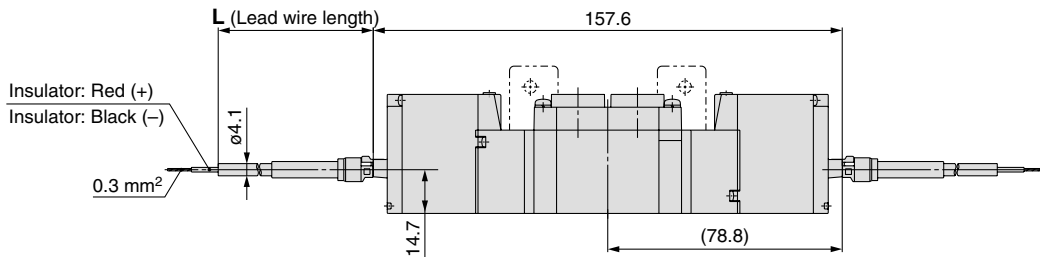

With IP65 compliant cable (TT)

51-SY7220-□TT□□-02□ (-F2)

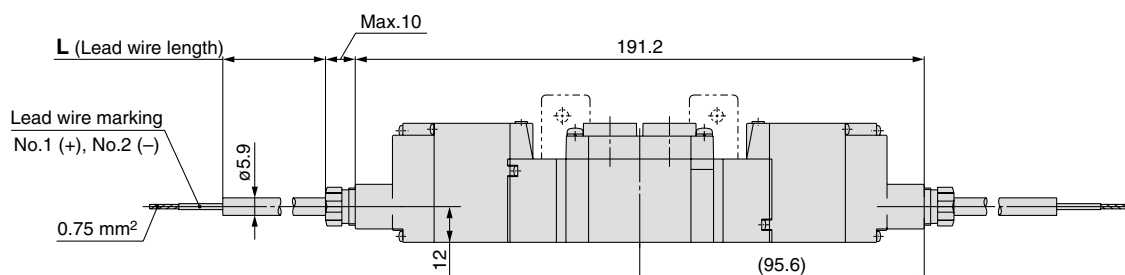

Series 51-SY5000/7000/9000

Dimensions: 51-SY7000

3-position closed center/exhaust center/pressure center

L-type plug connector (L)

51-SY7³/₄20-□L□□-02□ (-F2)

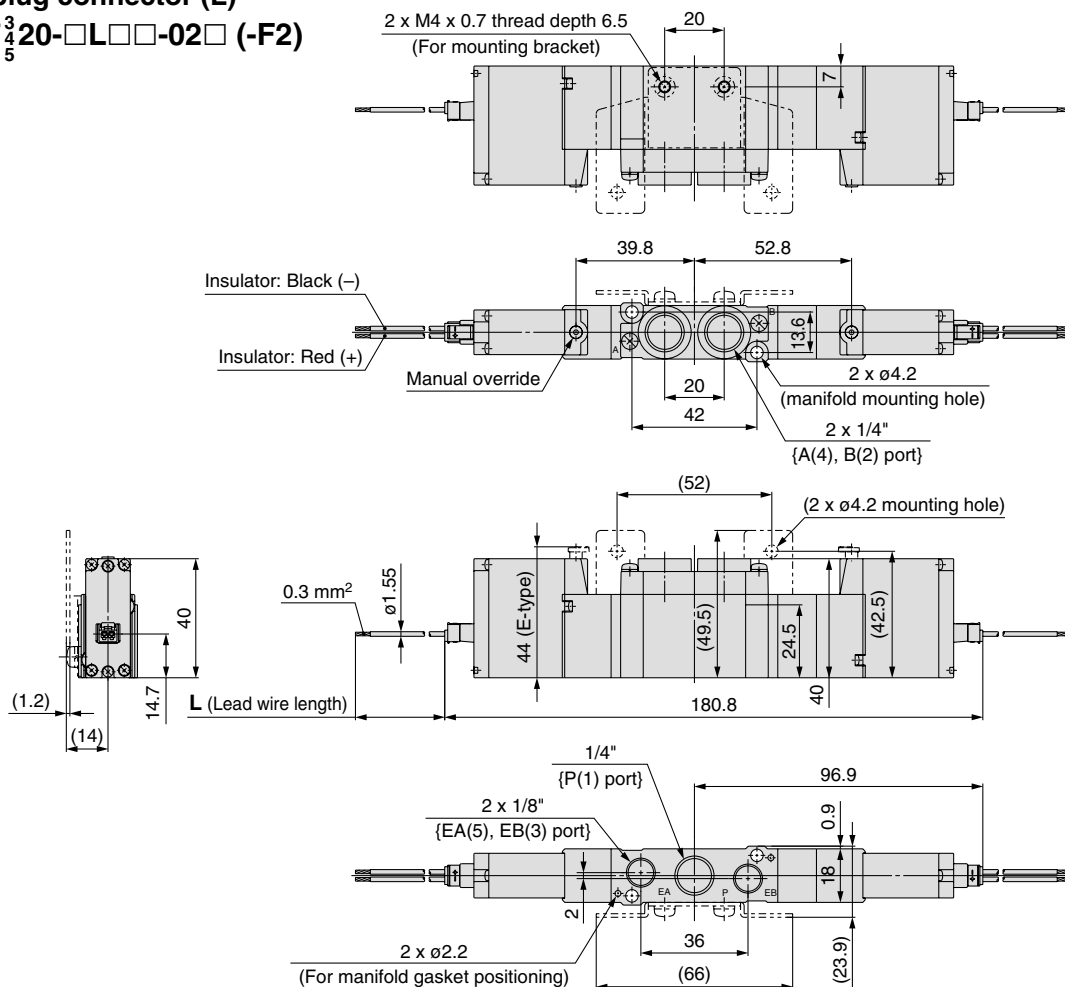

L-type plug connector with cover (LL)

51-SY7³/₄20-□LL□□-02□ (-F2)

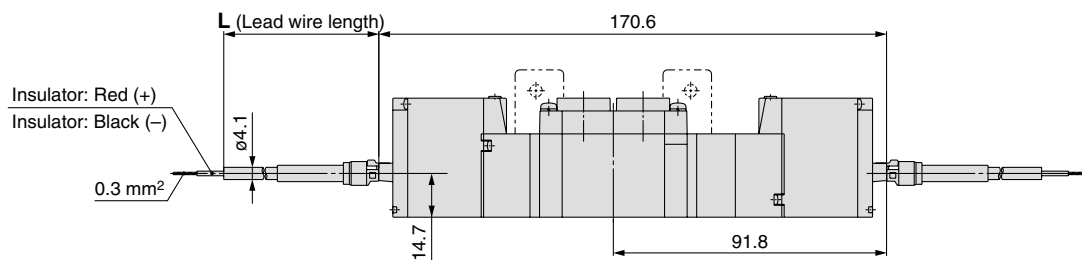

With IP65 compliant cable (TT)

51-SY7³/₄20-□TT□□-02□ (-F2)

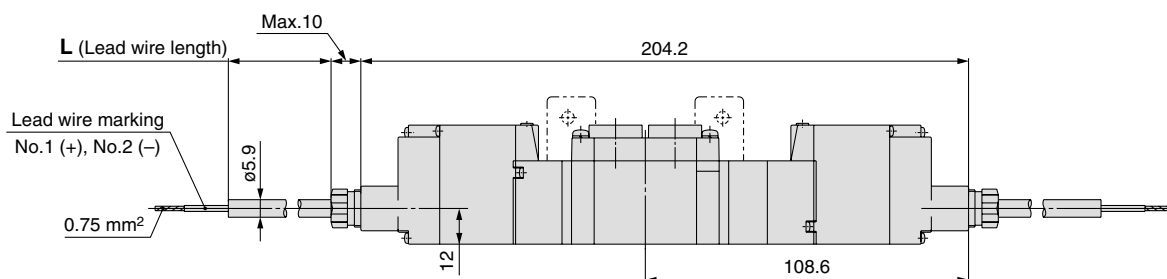

Body Ported *Series 51-SY5000/7000/9000*

Dimensions: 51-SY9000

2-position single
L-type plug connector (L)
51-SY9120-□L□□-02□

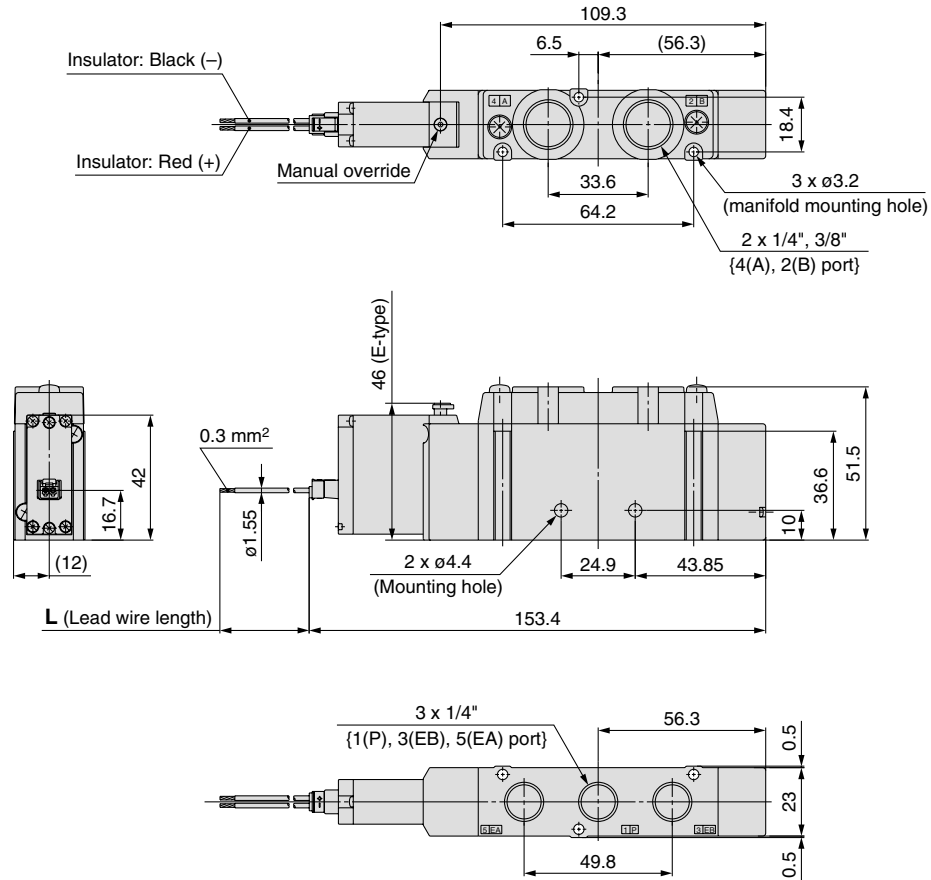

L-type plug connector with cover (LL)
51-SY9120-□LL□□-02□

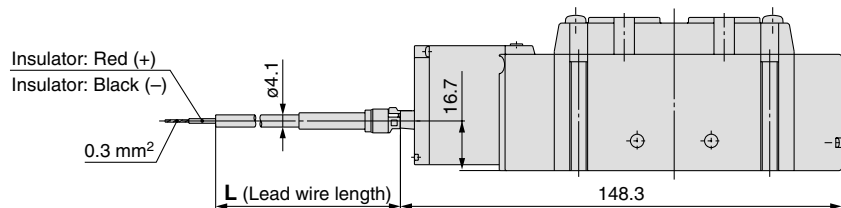

With IP65 compliant cable (TT)
51-SY9120-□TT□□-02□

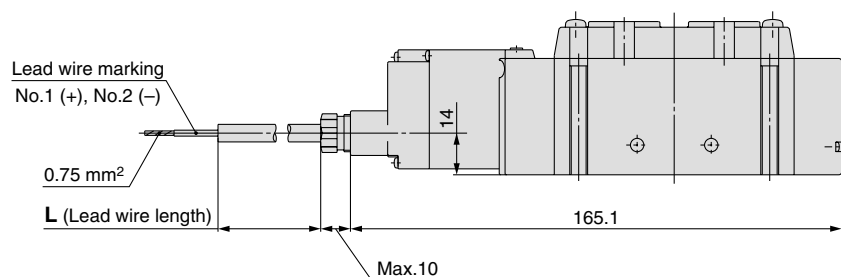

Series 51-SY5000/7000/9000

Dimensions: 51-SY9000

2-position double
L-type plug connector (L)
51-SY9220-□L□□-02□
03□

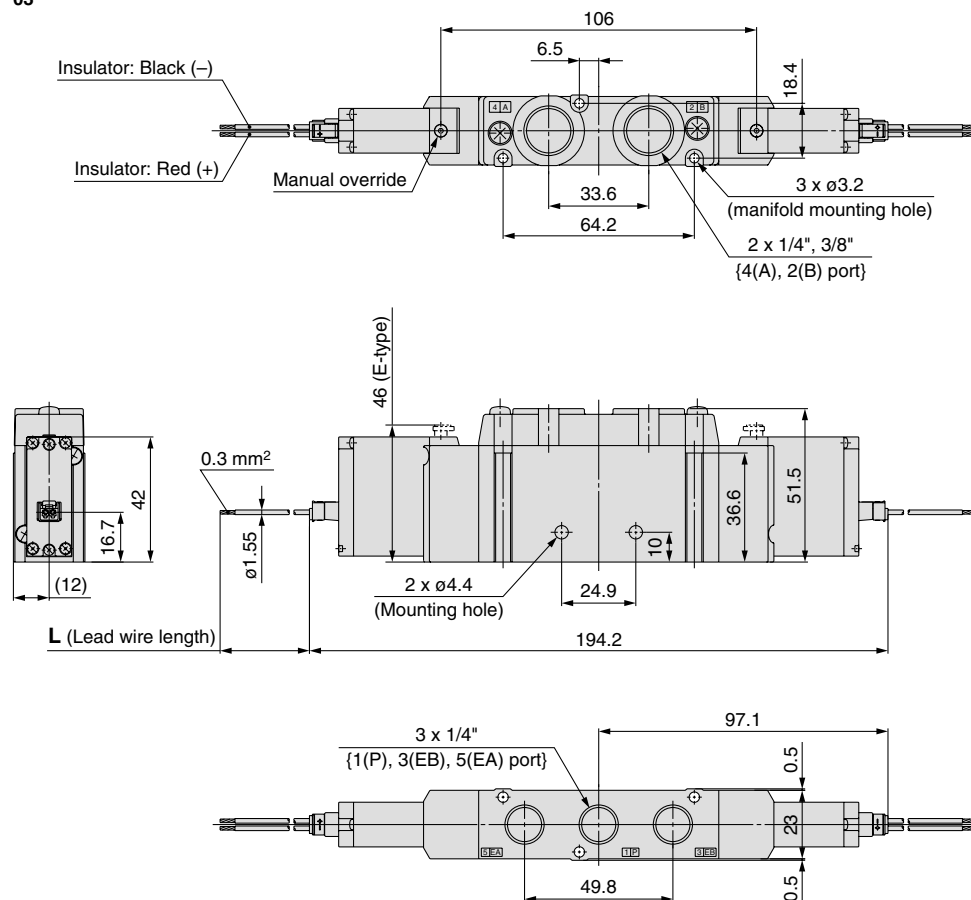

L-type plug connector with cover (LL)

51-SY9220-□LL□□-02□
03□

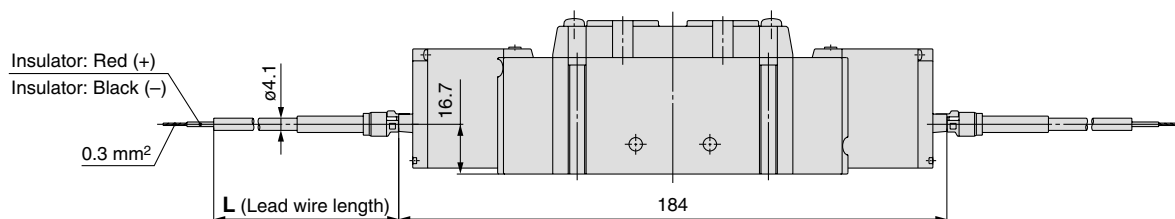

With IP65 compliant cable (TT)

51-SY9220-□TT□□-02□
03□

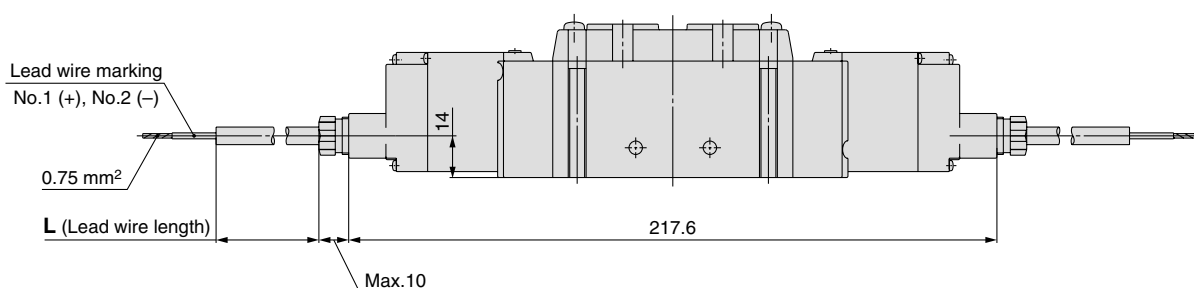

Dimensions/51-SY9000

3-position closed centre/exhaust centre/pressure centre L plug connector (L)

3
51-SY9420-L□□-02□□
5

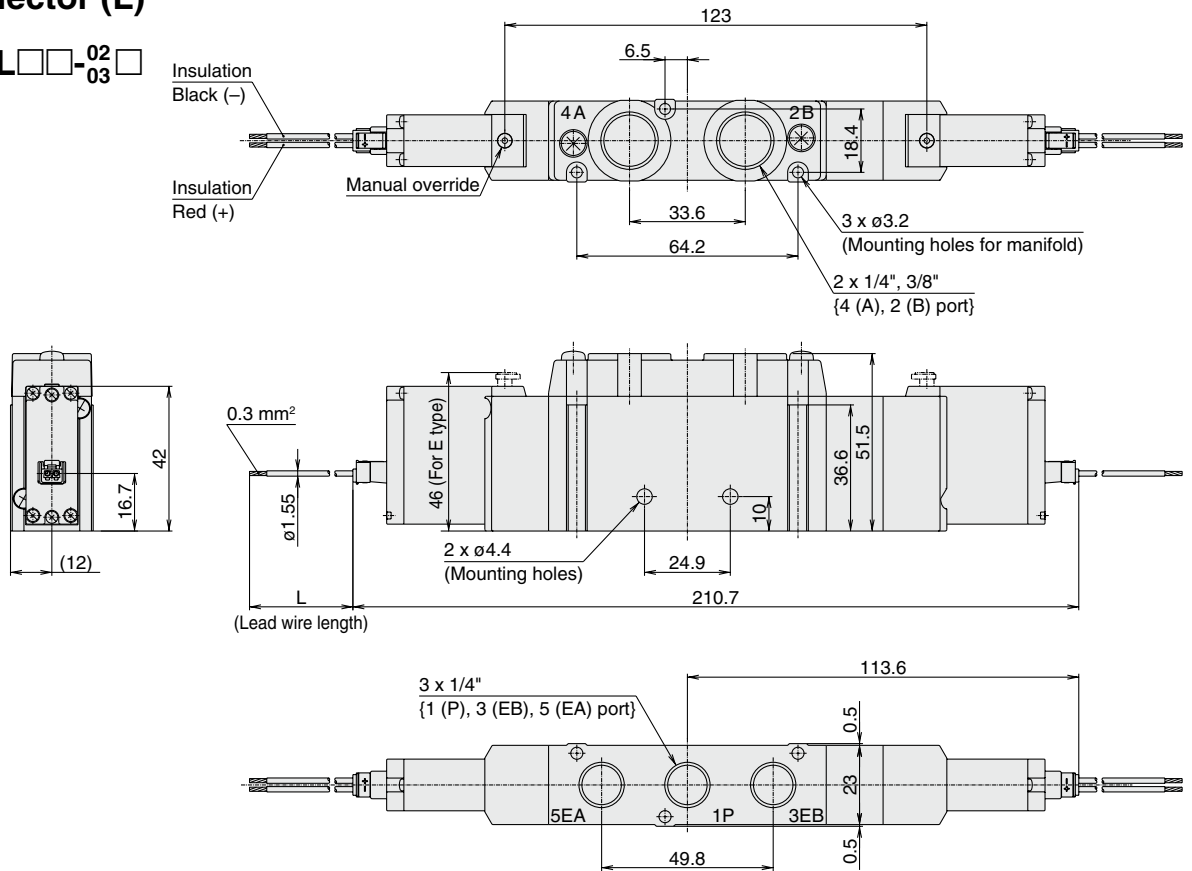

L plug connector with cover (LL)

3
51-SY9420-LL□□-02□□
5

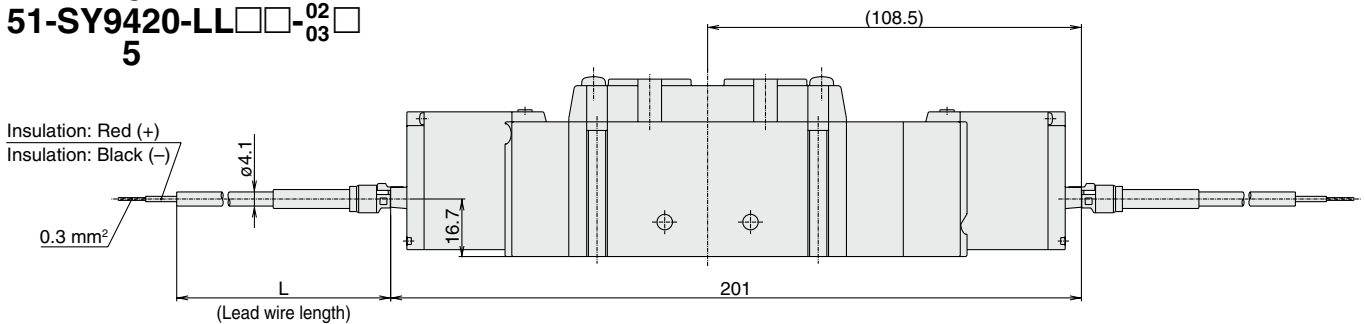

With IP65 compliant cable (TT)

3
51-SY9420-TT□□-02□□
5

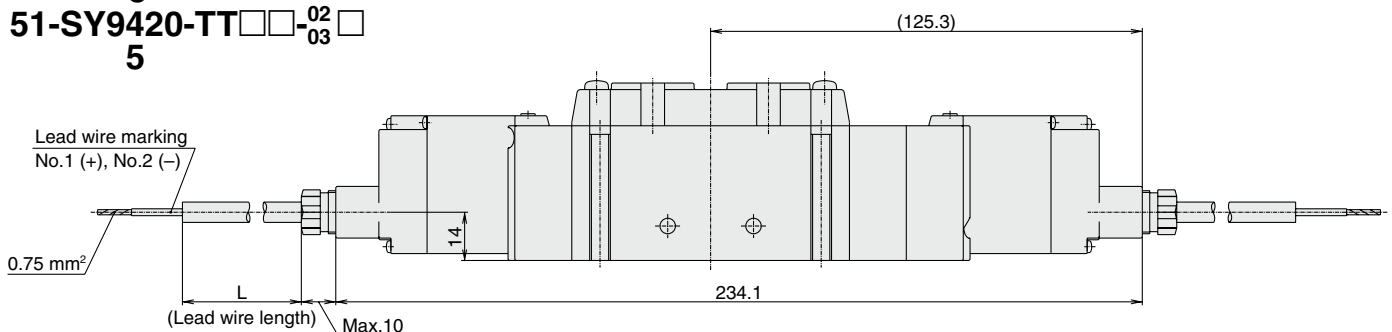

Intrinsically Safe Explosion-proof 5 Port Solenoid Valve Series 51-SY5000/7000/9000 Base Mounted Single Unit

How to Order

51 - SY 5 2 40 - A LL - - -

Series

5	51-SY5000
7	51-SY7000
9	51-SY9000

Explosion-proof

51	Intrinsically safe explosion-proof structure
----	--

Type of actuation

1	2-position single (A)4 2(B) (EA)5 1 3(EB) (P)
2	2-position double (A)4 2(B) (EA)5 1 3(EB) (P)
3 Note)	3-position closed center (A)4 2(B) (EA)5 1 3(EB) (P)
4 Note)	3-position exhaust center (A)4 2(B) (EA)5 1 3(EB) (P)
5 Note)	3-position pressure center (A)4 2(B) (EA)5 1 3(EB) (P)

Note) 3-position type is not available for the 51-SY9000 series.

Pilot type

Nil	Internal pilot
R	External pilot

Barrier designation Note 1) Note 2)

Nil	Without barrier
A	Z728.H
F	KFD0-SD2-Ex1.1065

Note 1) Attached barrier type
Note 2) Contact Pepperl+Fuchs for details on the barrier specifications.

Thread type

Nil	Rc
F	G
N	NPT
T	NPTF

Port size

Symbol	Port size	Applicable series
Nil	Without sub-plate	
02	1/4 With sub-plate	51-SY5000 51-SY7000
03	3/8 With sub-plate	51-SY7000 51-SY9000
04	1/2 With sub-plate	51-SY9000

Manual override

Nil: Non-locking push type 	D: Push-turn locking slotted type 	E: Push-turn locking lever type
---------------------------------------	--	--

Lead wire length

Symbol	Lead wire length	Note
3	300 mm	—
6	600 mm	Maximum length for L-type
10	1000 mm	—
15	1500 mm	—
20	2000 mm	—
30	3000 mm	—
100	10000 mm	Semi-standard

Electrical entry

Symbol	Electrical entry
L	L-type plug connector
LL	L-type plug connector with cover
TT Note)	With IP65 compliant cable Ground nut

Note) TT-type is connected to the terminal block.
Cables other than the connected one cannot be used.

Series 51-SY5000/7000/9000

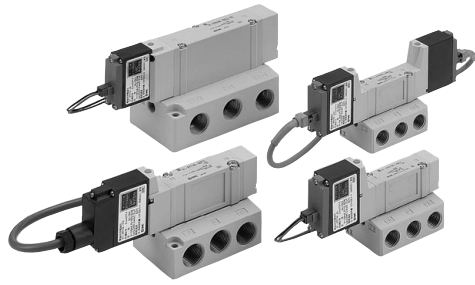

Specifications

Series		51-SY5000	51-SY7000	51-SY9000
Fluid		Air		
Internal pilot operating pressure range (MPa)	2-position single	0.15 to 0.7		
	2-position double	0.1 to 0.7		
	3-position	0.2 to 0.7		
External pilot operating pressure range (MPa)	Operating pressure range		-100 kPa to 0.7	
	Pilot pressure range	2-position single	0.25 to 0.7	
		2-position double	0.25 to 0.7	
	3-position	0.25 to 0.7		
Ambient and fluid temperature (°C)		-10 to 50 (No freezing)		
Max. operating frequency (Hz)	2-position single, double	1		
	3-position			
Manual override (Manual operation)		Non-locking push type, Push-turn locking slotted type, Push-turn locking lever type		
Pilot exhaust method	Internal pilot	Main/Pilot valve common exhaust		
	External pilot	Pilot valve individual exhaust		
Lubrication		Not required		
Mounting orientation		Unrestricted		
Impact/Vibration resistance (m/s ²) ^{Note 1)}		150/30		
Enclosure (Based on IEC60529)		IP30 (L-type), IP40 (LL-type), IP65 (TT-type)		
Electrical entry		L-type plug connector (L), L-type plug connector with cover (LL), With IP65 compliant cable (TT)		
Coil rated voltage		12 VDC		
Allowable voltage fluctuation		-10% to +10% of rated voltage		
Coil insulation type		Class B		
Power consumption		0.52 W (at rated voltage)		
Type of explosion-proof structure		Intrinsically safe explosion-proof structure (ia) ^{Note 2)}		
Applicable gas or ignition temperature of steam and explosion class		IIC T5		
Voltage to barrier		24 VDC ^{Note 3) Note 4)}		
Tolerant voltage fluctuation		-10% to +10% of rated voltage		

Note 1) Impact resistance: No malfunction occurred when it is tested in the axial direction and at the right angles to the main valve and armature in both energized and de-energized states every once for each condition. (Values at the initial period)

Vibration resistance: No malfunction occurred in a one-sweep test between 45 and 2000 Hz. Test was performed at both energized and de-energized states in the axial direction and at the right angles to the main valve and armature. (Values at the initial period)

Note 2) **Warning** Can not be used in a class-0 environment. Use in a class-2 or class-1 environment.

Note 3) **Caution** The valve and barrier have polarity. If voltage is supplied with wrong polarity, the barrier can not be used.

Note 4) **Caution** Voltage to the valve should be 10.8 VDC (minimum value).

Response Time

Note) Based on dynamic performance test, JIS B 8375-1981.
(Coil temperature: 20°C, barrier A, F at 24 VDC)

Type of actuation	Response time (ms) (at 0.5 MPa)		
	51-SY5000	51-SY7000	51-SY9000
2-position single	26 or less	38 or less	50 or less
2-position double	22 or less	30 or less	50 or less
3-position	38 or less	56 or less	—

Flow-rate Characteristics

Series 51-SY5000

Valve model	Type of actuation		Port size	Flow-rate characteristics ^{Note)}					
				1→4/2 (P→A/B)			4/2→5/3 (A/B→EA/EB)		
				C(dm ³ /(s·bar))	b	Cv	C(dm ³ /(s·bar))	b	Cv
51-SY5□40-□ -02	2-position	Single	1/4	2.4	0.41	0.64	2.8	0.29	0.66
		Double							
	3-position	Closed center		1.8	0.47	0.50	1.8	0.40	0.47
		Exhaust center		1.4	0.55	0.44	3.0 [1.2]	0.33 [0.48]	0.72 [0.37]
	Pressure center	3.3 [0.84]	0.36 [0.60]	0.85 [0.28]	1.8	0.40	0.48		

 Note) []: Normal position

Series 51-SY7000

Valve model	Type of actuation		Port size	Flow-rate characteristics ^{Note)}					
				1→4/2 (P→A/B)			4/2→5/3 (A/B→EA/EB)		
				C(dm ³ /(s·bar))	b	Cv	C(dm ³ /(s·bar))	b	Cv
51-SY7□40-□ -02	2-position	Single	1/4	4.1	0.41	1.1	4.1	0.29	1.0
		Double							
	3-position	Closed center		3.0	0.43	0.80	2.6	0.41	0.72
		Exhaust center		2.6	0.42	0.71	4.7 [1.7]	0.35 [0.48]	1.1 [0.49]
	Pressure center	5.3 [2.3]	0.39 [0.49]	1.3 [0.65]	2.2	0.49	0.63		
51-SY7□40-□ -03	2-position	Single	3/8	4.9	0.29	1.2	4.5	0.27	1.1
		Double							
	3-position	Closed center		3.0	0.40	0.80	2.6	0.45	0.73
		Exhaust center		2.6	0.42	0.71	4.8 [1.7]	0.35 [0.48]	1.1 [0.49]
	Pressure center	5.3 [2.3]	0.31 [0.51]	1.3 [0.64]	2.3	0.45	0.66		

 Note) []: Normal position

Series 51-SY9000

Valve model	Type of actuation		Port size	Flow-rate characteristics					
				1→4/2 (P→A/B)			4/2→5/3 (A/B→EA/EB)		
				C(dm ³ /(s·bar))	b	Cv	C(dm ³ /(s·bar))	b	Cv
51-SY9□40-□ -03	2-position	Single	3/8	7.9	0.34	2.0	9.6	0.43	2.6
Double									
51-SY9□40-□ -04	2-position	Single	1/2	8.0	0.48	2.2	10	0.29	2.5
Double									

Series 51-SY5000/7000/9000

Construction

Series SY

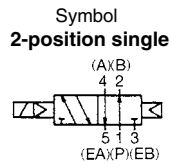

2-position single

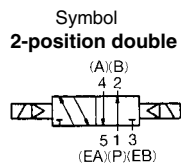
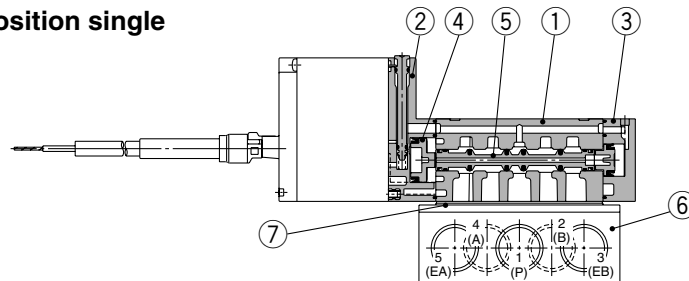

2-position double

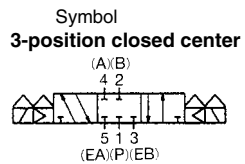
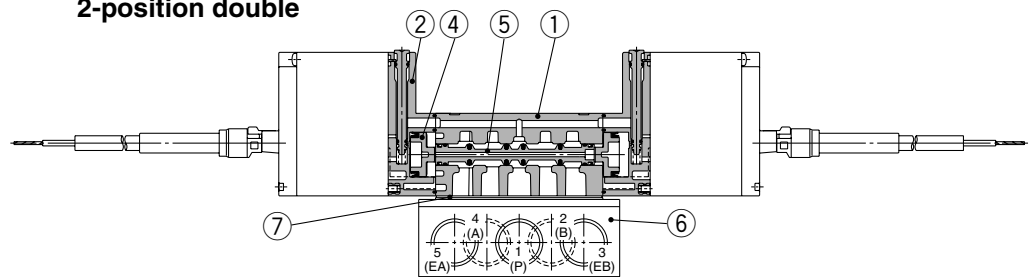

3-position closed center/exhaust center/pressure center

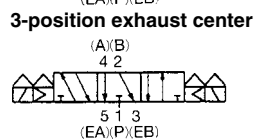
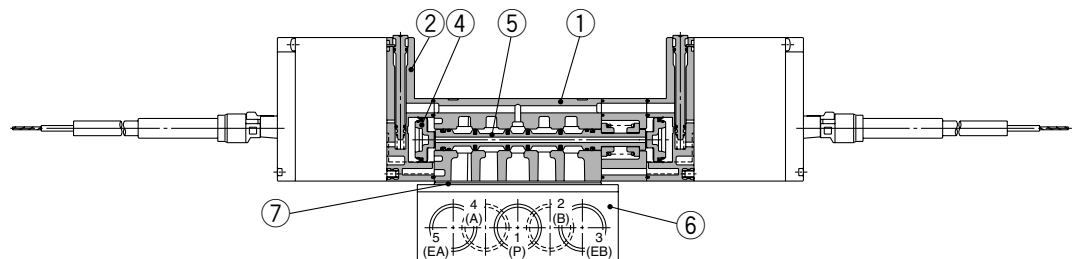

3-position pressure center

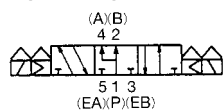

(This figure shows a closed center type.)

Component Parts

No.	Description	Material	Note
1	Body	Aluminum die-casted	White
2	Adapter plate	Resin	White (51-SY9000: Gray)
3	End plate	Resin	White
4	Piston	Resin	—
5	Spool valve assembly	Aluminum, HNBR	—

Replacement Parts

No.	Description	Part no.			Note
		51-SY5□40	51-SY7□40	51-SY9□40	
6	Sub-plate	SY5000-27-1*	1/4: SY7000-27-1* 3/8: SY7000-27-2*	3/8: SY9000-27-1* 1/2: SY9000-27-2*	Aluminum die-casted
7	Gasket	SY5000-11-15	SY7000-11-11	SY9000-11-2	HNBR
—	Round head combination screw	M3 x 26	M4 x 31	SY9000-18-2 (M3 x 42)	For valve mounting (Flat nickel plated)

* Thread type

Caution
Mounting screw
tightening torques

M3: 0.8 N·m
M4: 1.4 N·m

Series 51-SY5000/7000/9000

Dimensions: 51-SY5000

2-position double

L-type plug connector (L)

51-SY5240(R)-□L□□-02□

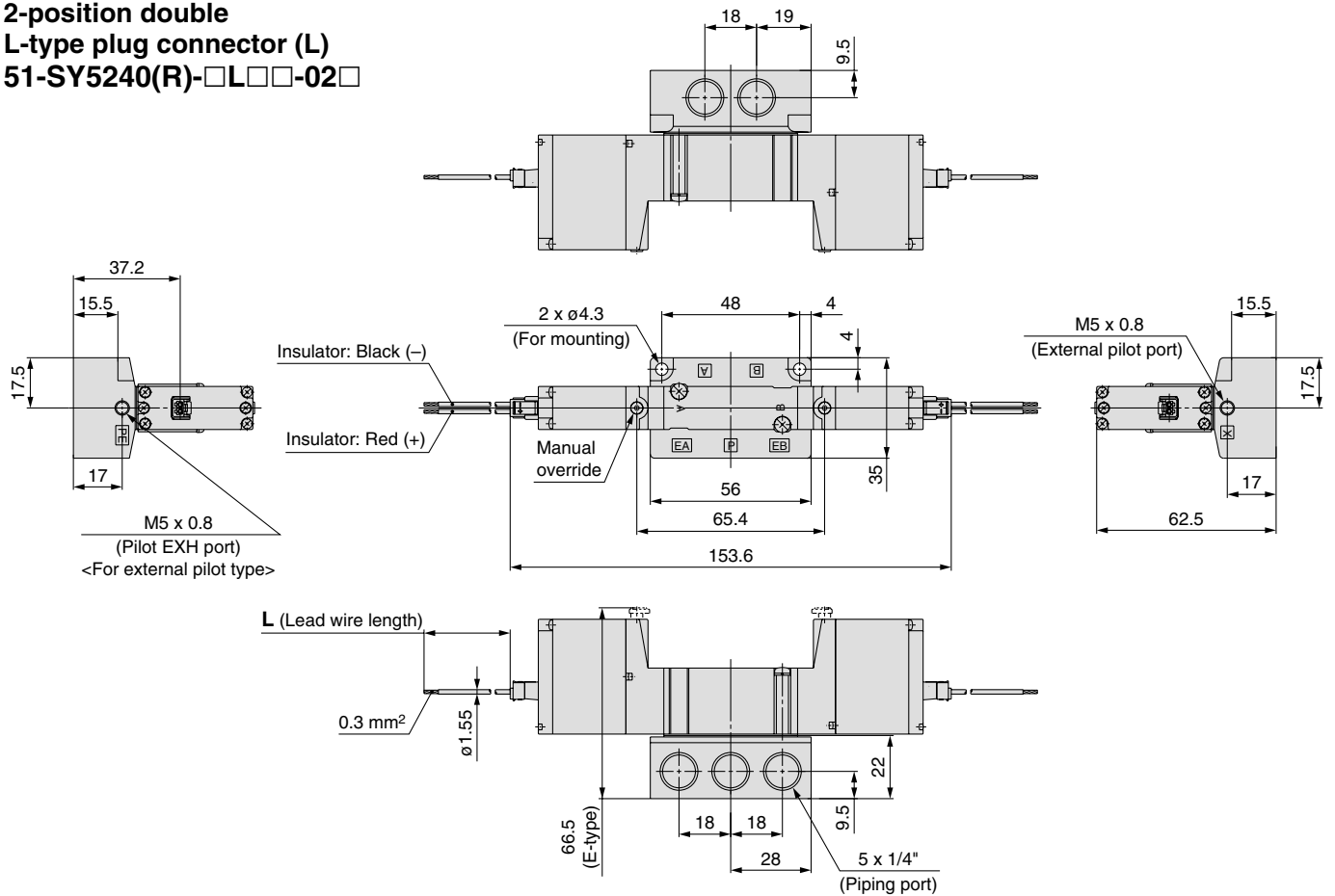

L-type plug connector with cover (LL)

51-SY5240(R)-□LL□□-02□

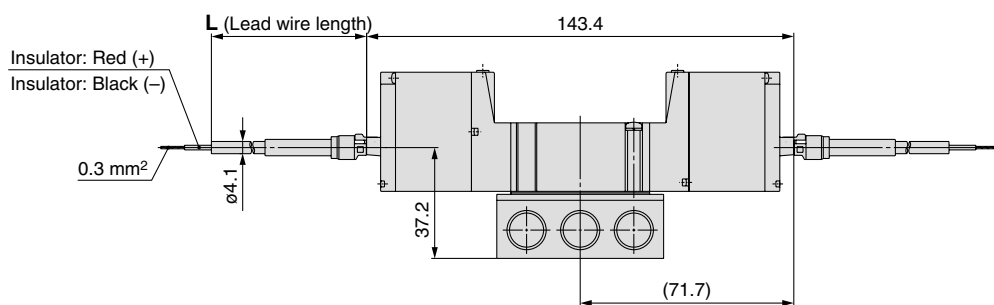

With IP65 compliant cable (TT)

51-SY5240(R)-□TT□□-02□

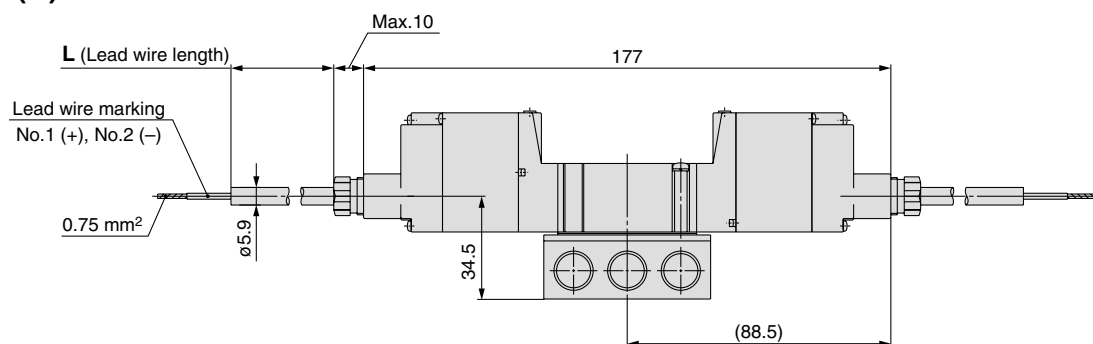

Dimensions: 51-SY5000

3-position closed center/exhaust center/pressure center

L-type plug connector (L)

51-SY5³/₄40(R)-□L□□-02□

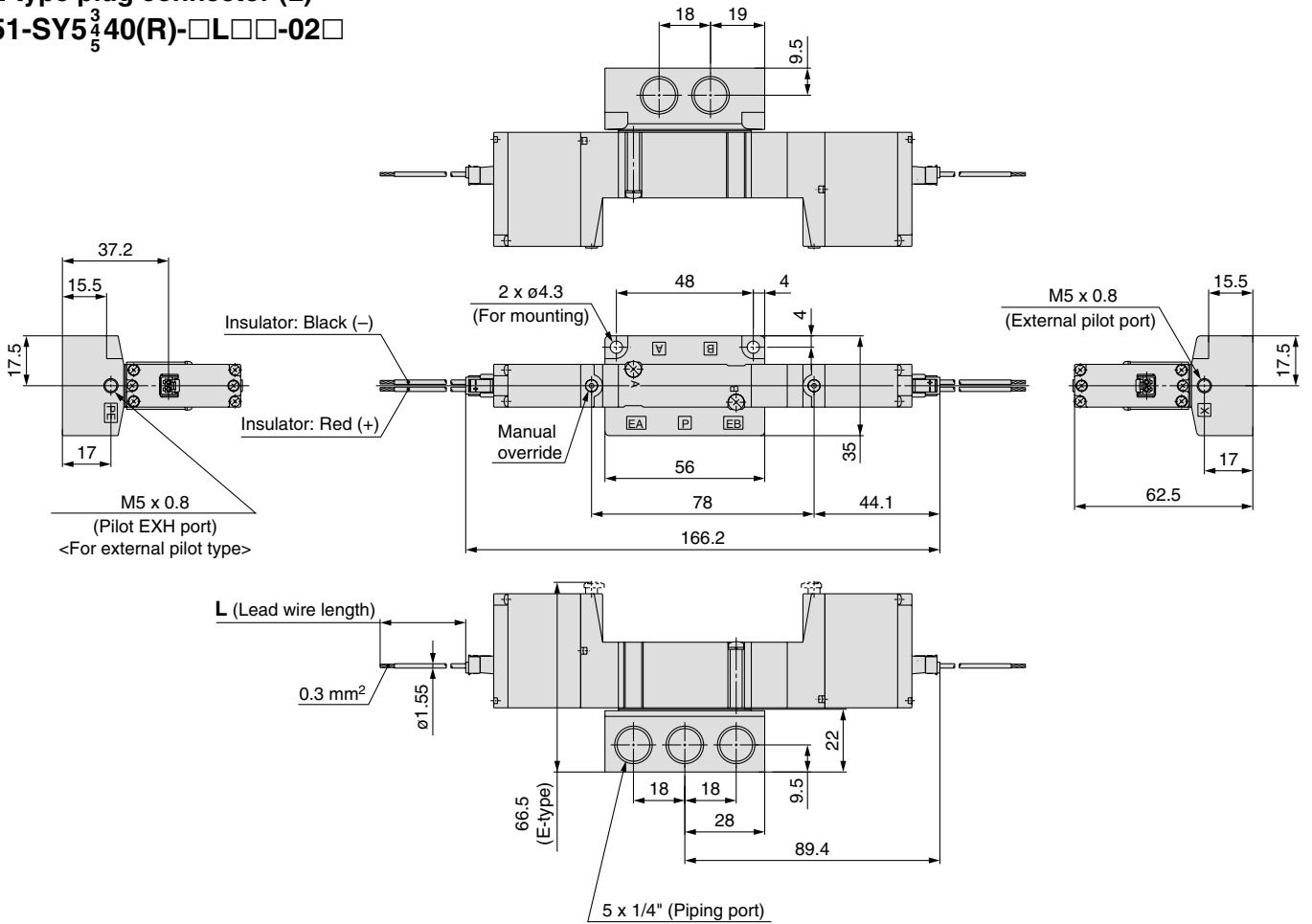

L-type plug connector with cover (LL)

51-SY5³/₄40(R)-□LL□□-02□

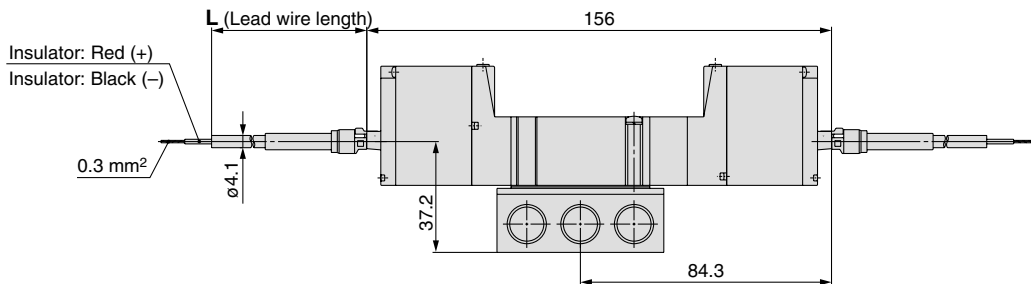

With IP65 compliant cable (TT)

51-SY5³/₄40(R)-□TT□□-02□

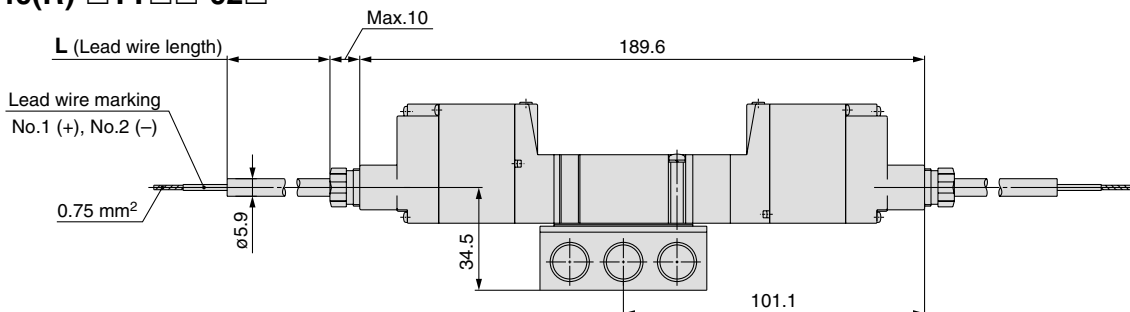

Series 51-SY5000/7000/9000

Dimensions: 51-SY7000

2-position single

L-type plug connector (L)

51-SY7140(R)-□L□□□-⁰²/₀₃□

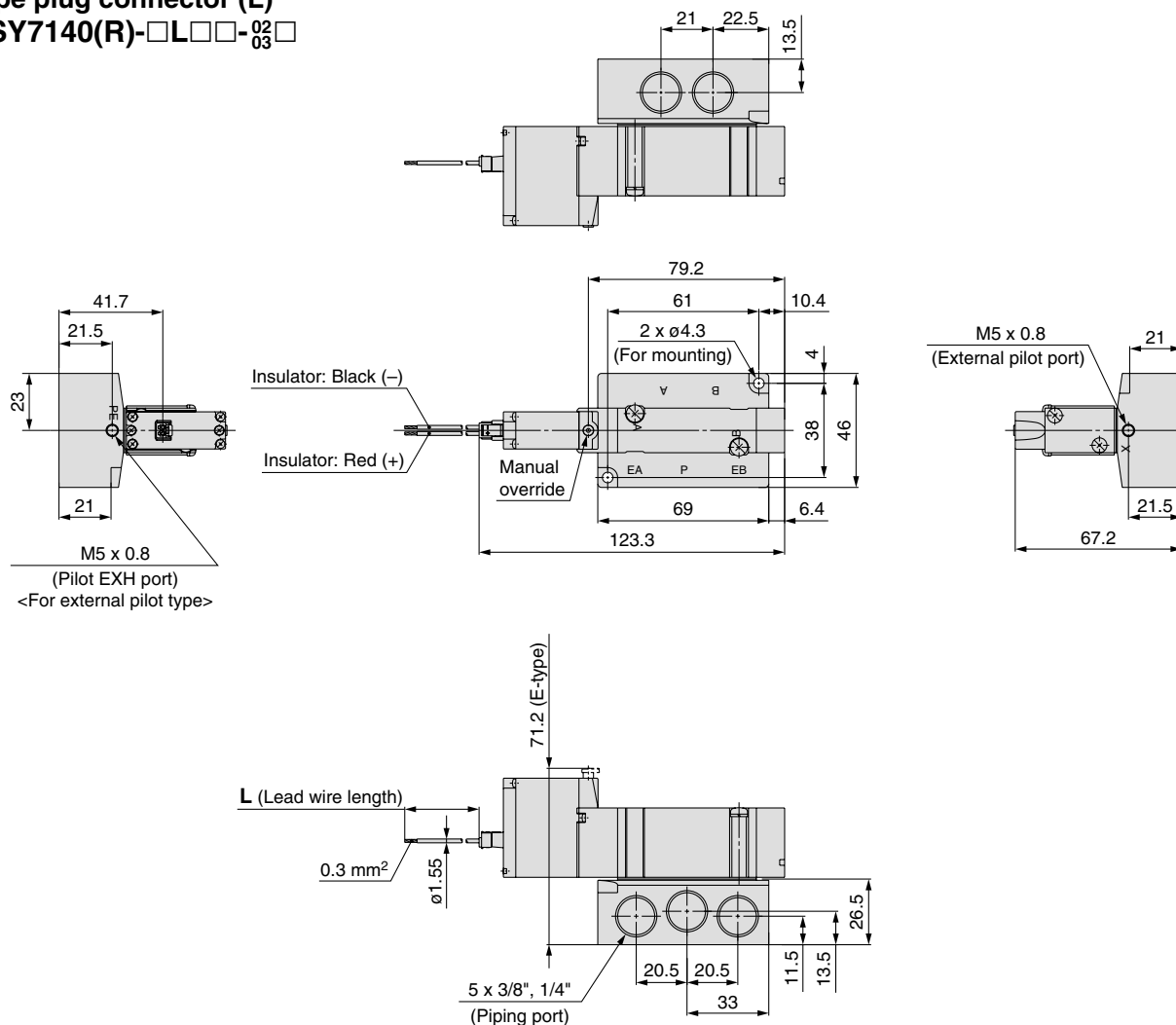

L-type plug connector with cover (LL)

51-SY7140(R)-□LL□□□-⁰²/₀₃□

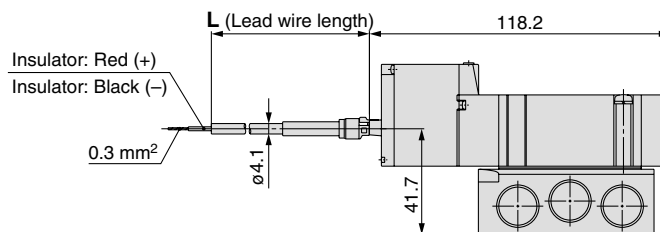

With IP65 compliant cable (TT)

51-SY7140(R)-□TT□□□-⁰²/₀₃□

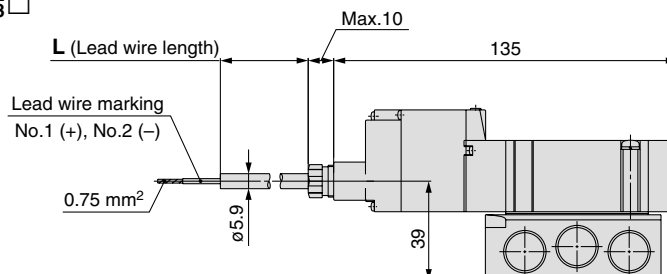

Base Mounted Series 51-SY5000/7000/9000

Dimensions: 51-SY7000

2-position double L-type plug connector (L)

51-SY7240(R)-□L□□-⁰²/₀₃□

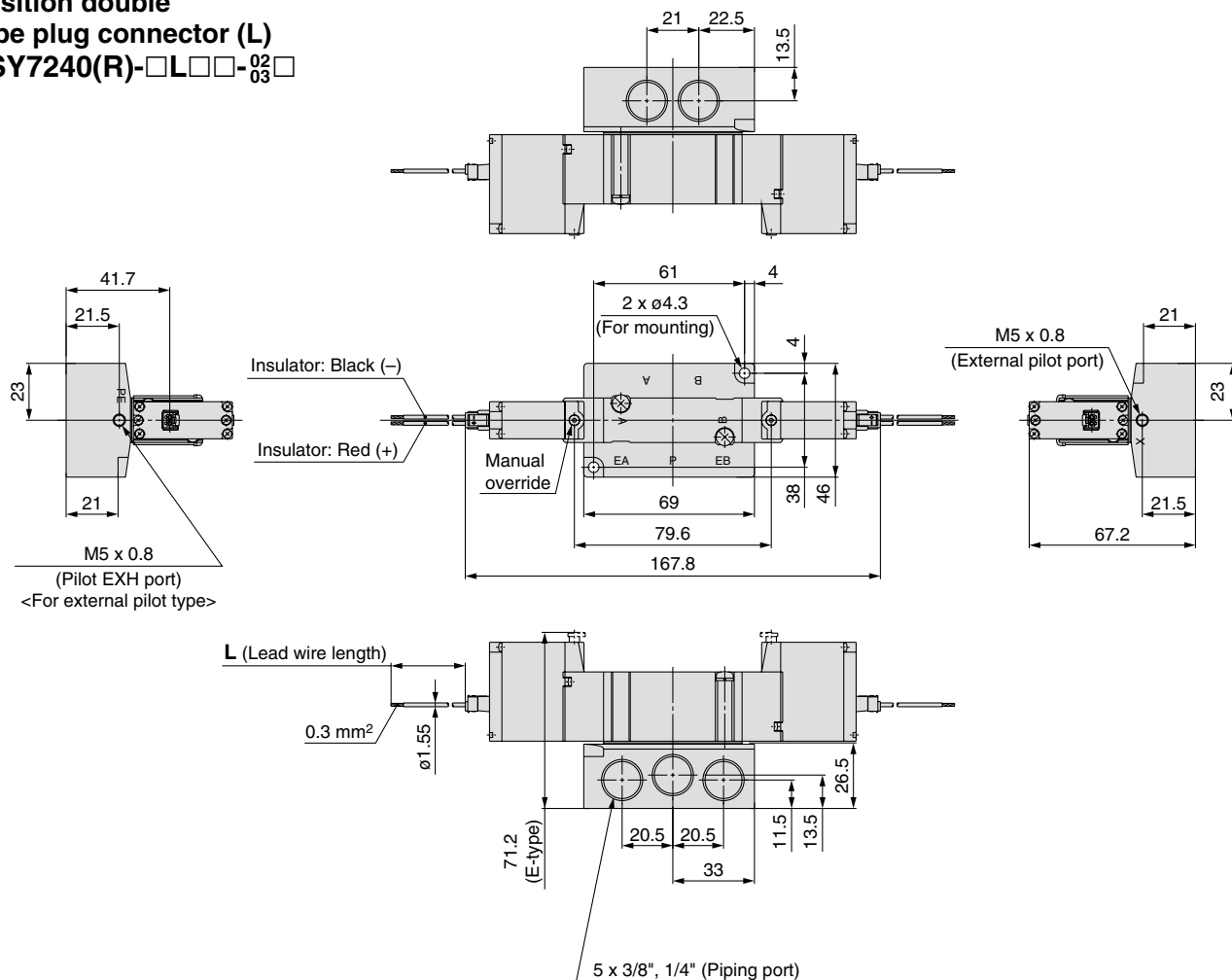

L-type plug connector with cover (LL)

51-SY7240(R)-□LL□□-⁰²/₀₃□

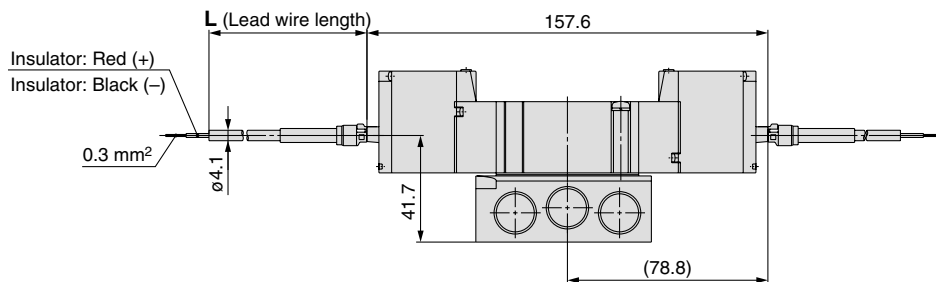

With IP65 compliant cable (TT)

51-SY7240(R)-□TT□□-⁰²/₀₃□

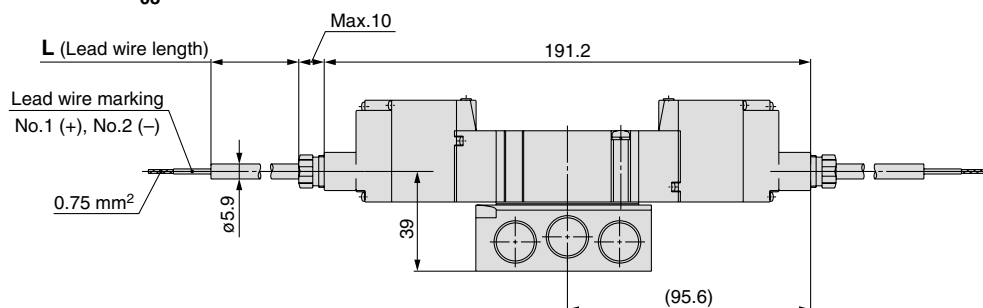

Series 51-SY5000/7000/9000

Dimensions: 51-SY7000

3-position closed center/exhaust center/pressure center

L-type plug connector (L)

51-SY7³/₄40(R)-□L□□-⁰²/₀₃□

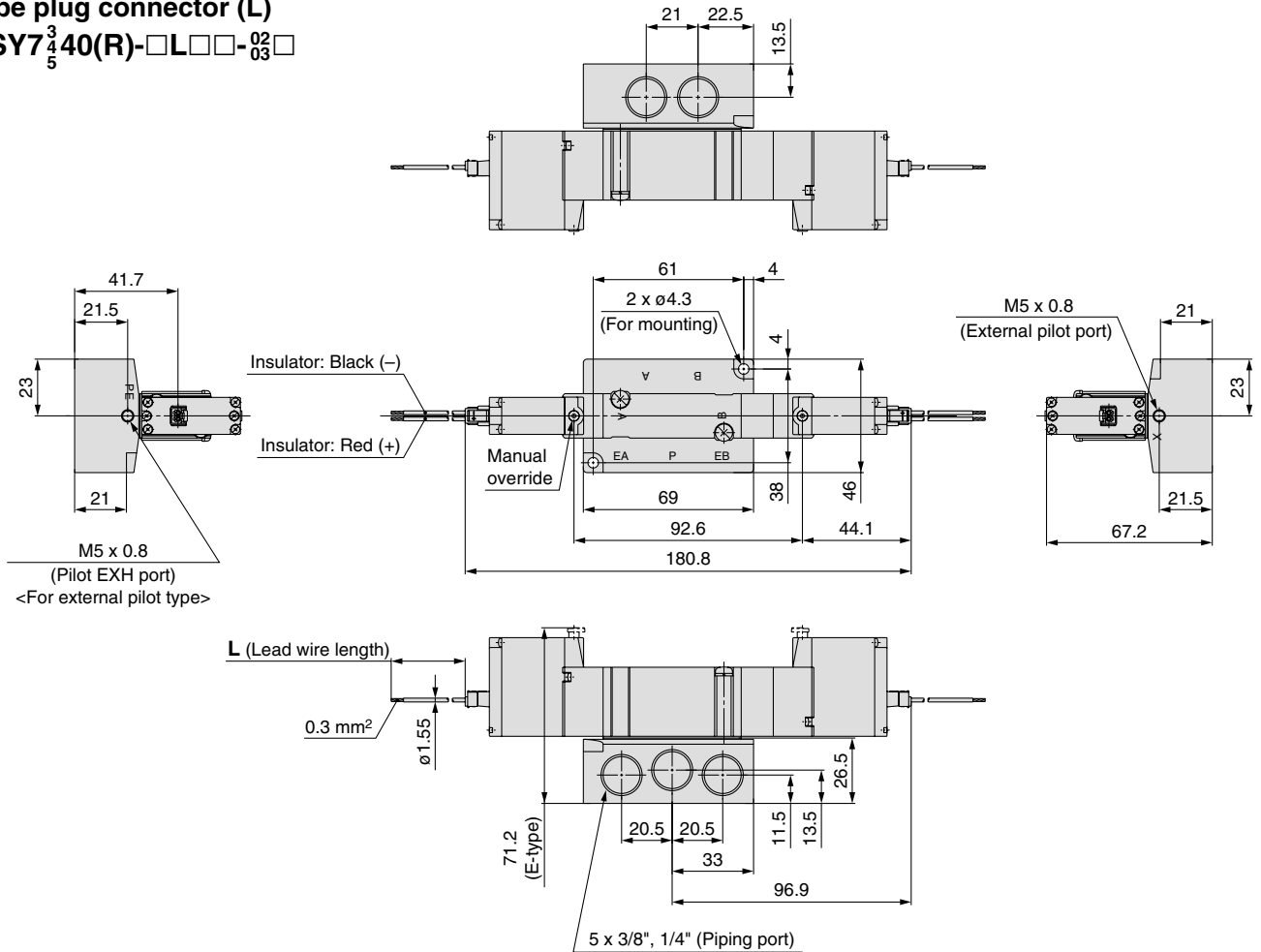

L-type plug connector with cover (LL)

51-SY7³/₄40(R)-□LL□□-⁰²/₀₃□

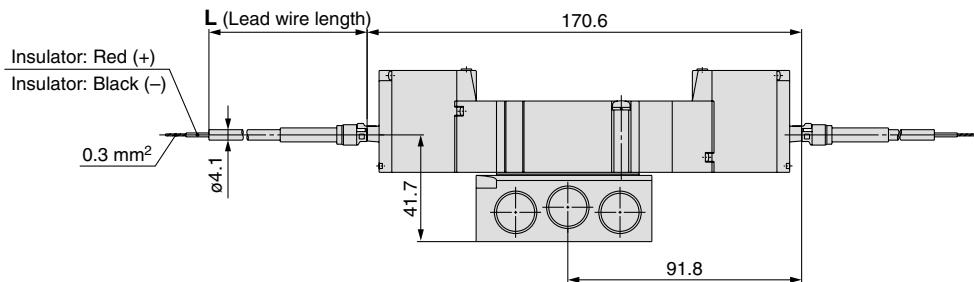

With IP65 compliant cable (TT)

51-SY7³/₄40(R)-□TT□□-⁰²/₀₃□

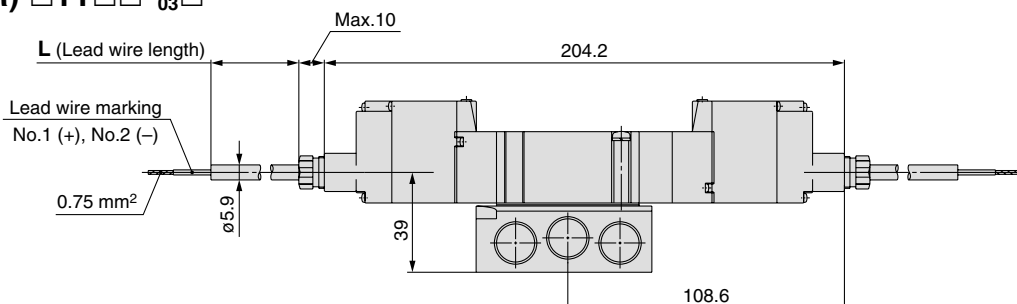

Dimensions: 51-SY9000

2-position single
L-type plug connector (L)
51-SY9140-□L□□-03□

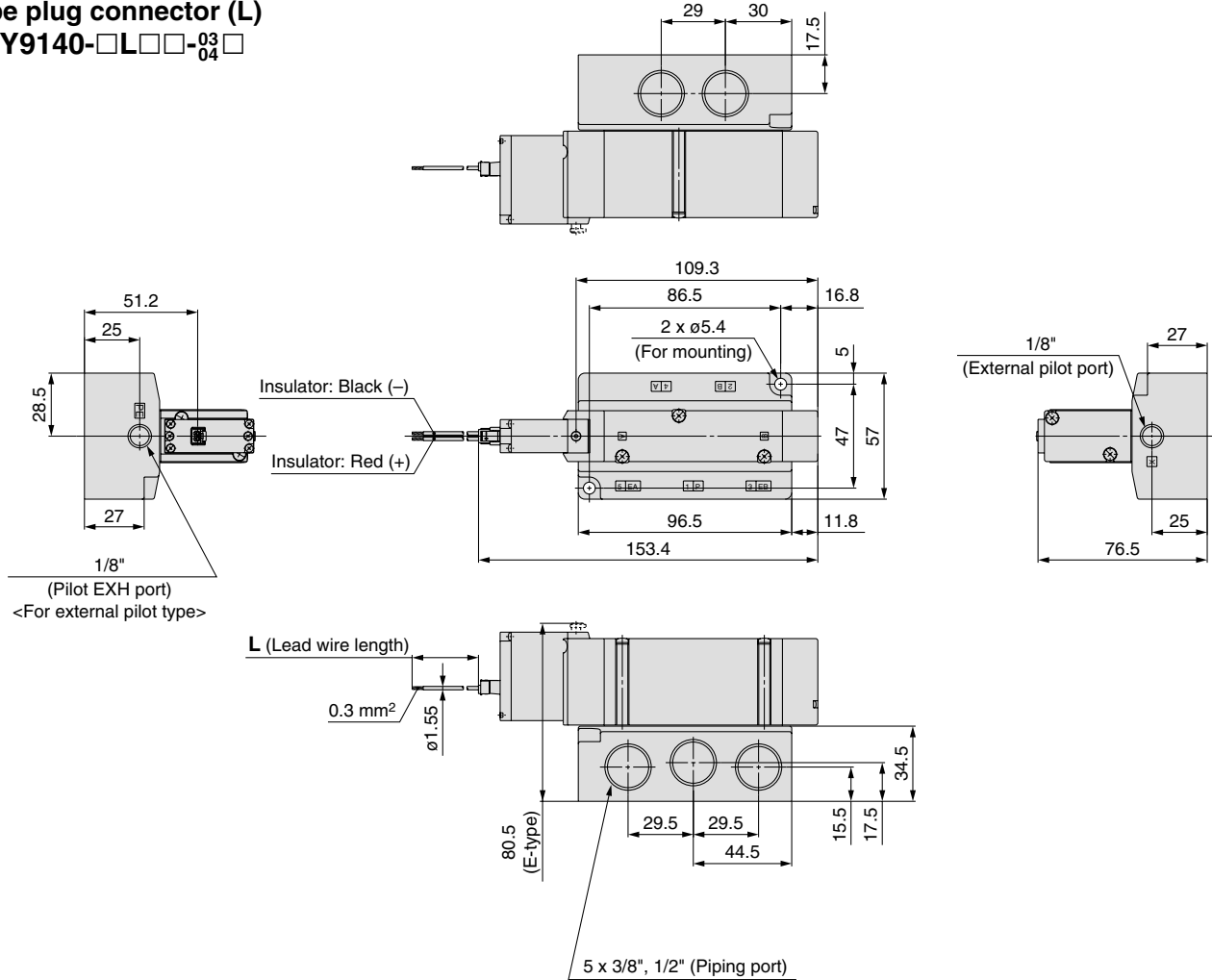

L-type plug connector with cover (LL)
51-SY9140-□LL□□-03□

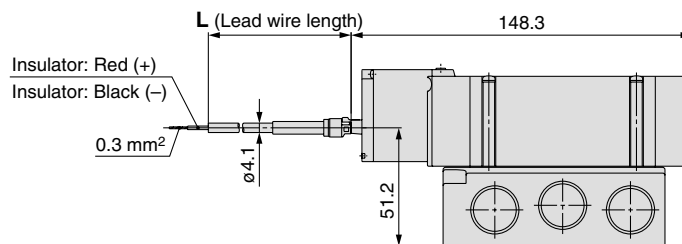

With IP65 compliant cable (TT)
51-SY9140-□TT□□-03□

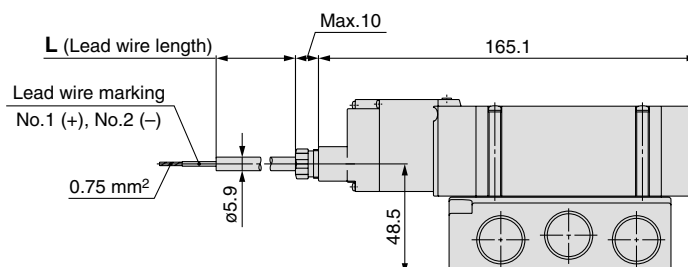

Series 51-SY5000/7000/9000

Dimensions: 51-SY9000

2-position double
L-type plug connector (L)

51-SY9240-□L□□-⁰³/₀₄□

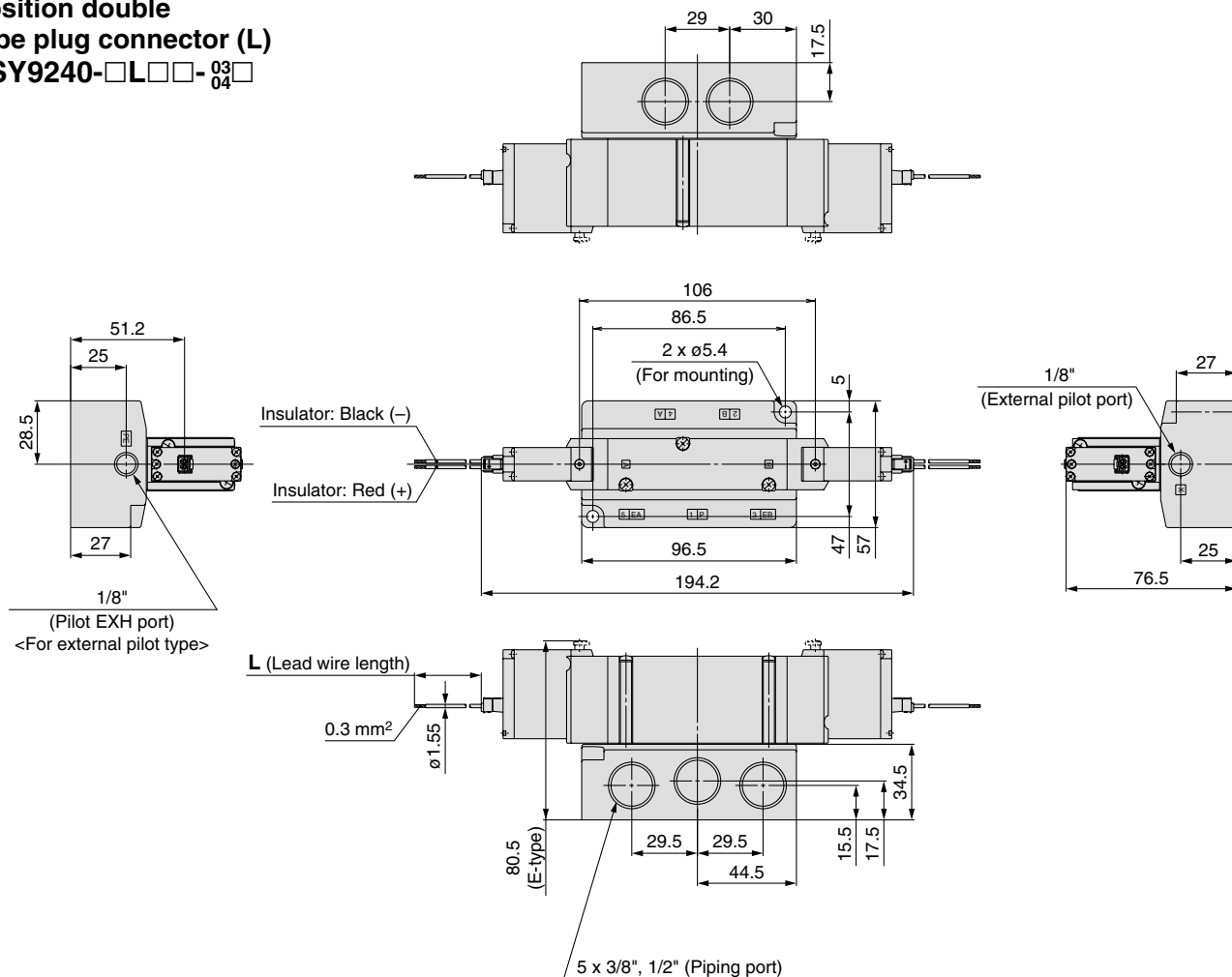

L-type plug connector with cover (LL)

51-SY9240-□LL□□-⁰³/₀₄□

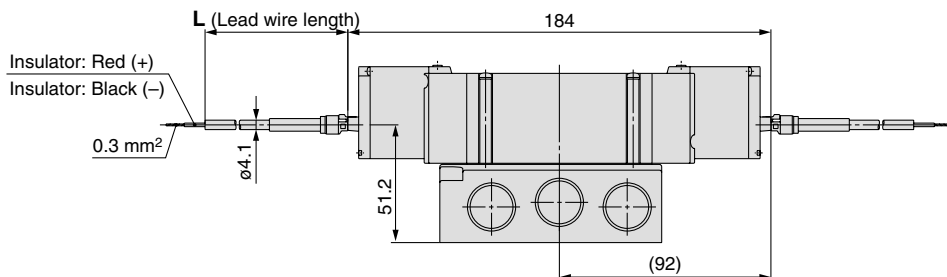

With IP65 compliant cable (TT)

51-SY9240-□TT□□-⁰³/₀₄□

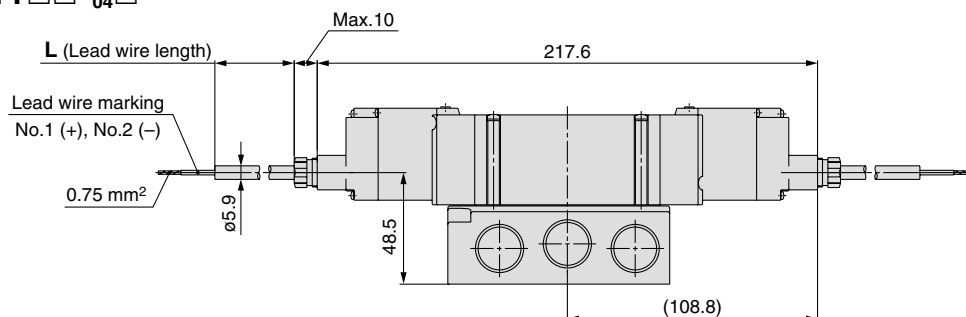

Dimensions/51-SY9000

**3-position closed centre/exhaust centre/
pressure centre**

L plug connector (L)

51-SY9440 (R) -L□□-³₅ 03 04

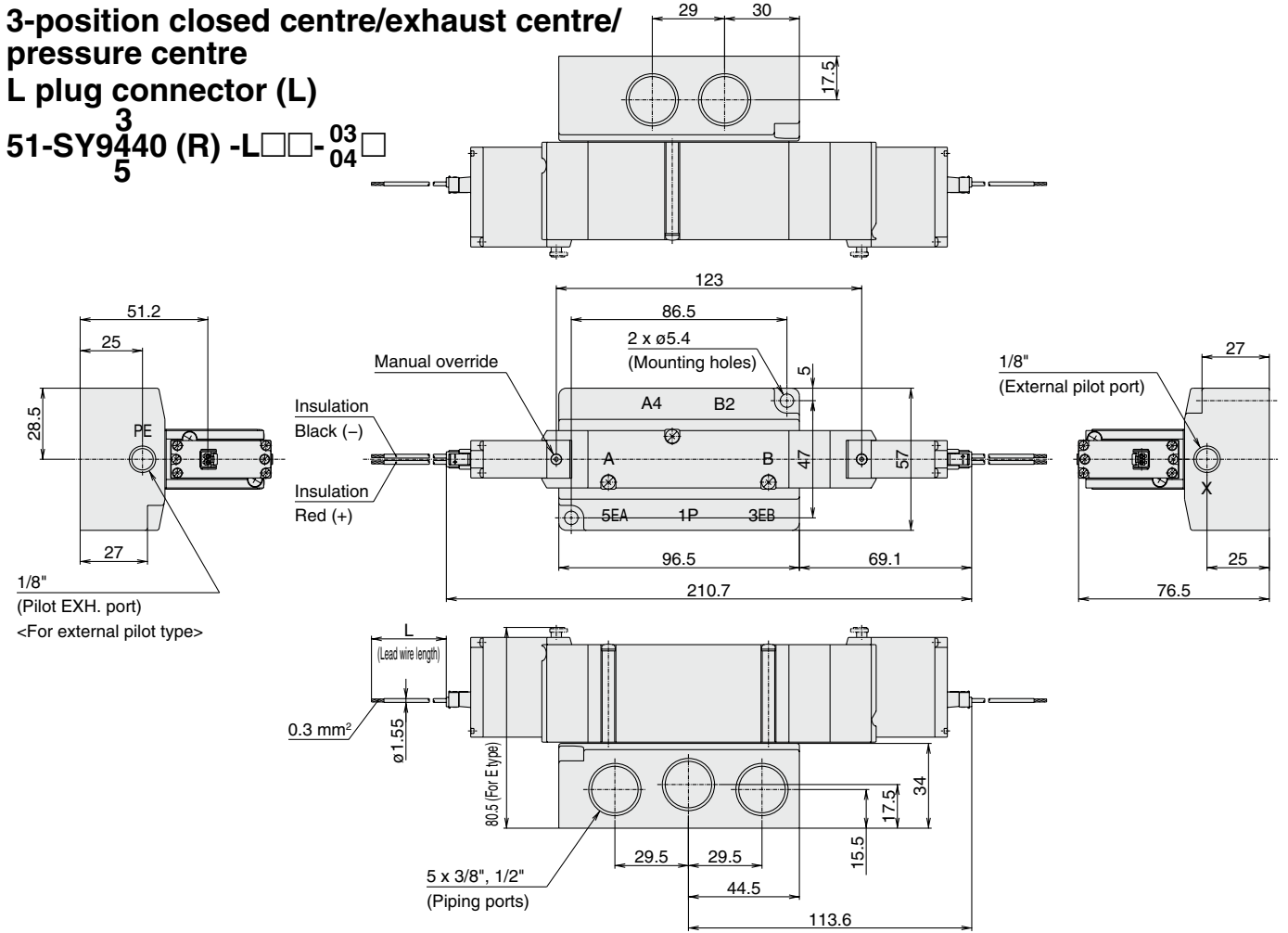

L plug connector with cover (LL)

51-SY9440 (R) -LL□□-³₅ 03 04

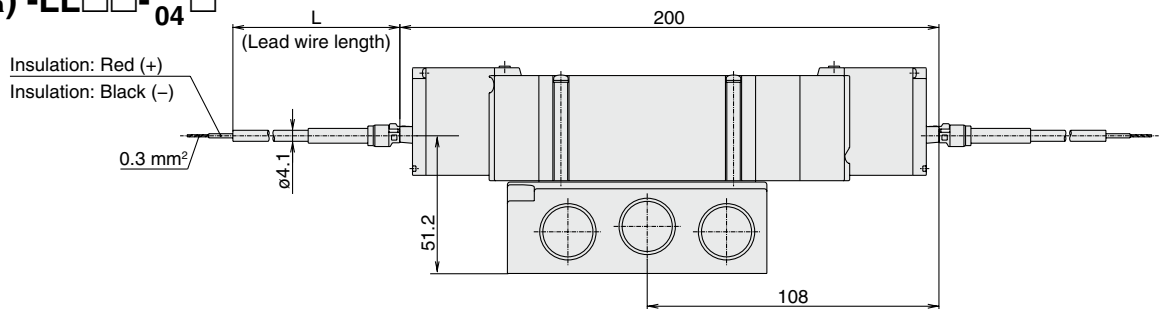

With IP65 compliant cable (TT)

51-SY9440 (R) -TT□□-³₅ 03 04

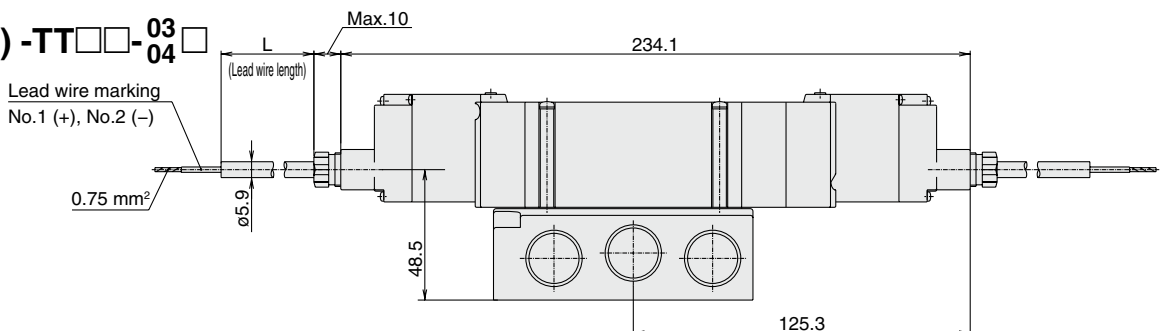

Intrinsically Safe Explosion-proof System

5 Port Solenoid Valve

Series 51-SY5000/7000

Body Ported Manifold

Bar Stock Type

Type **20**

How to Order Manifold

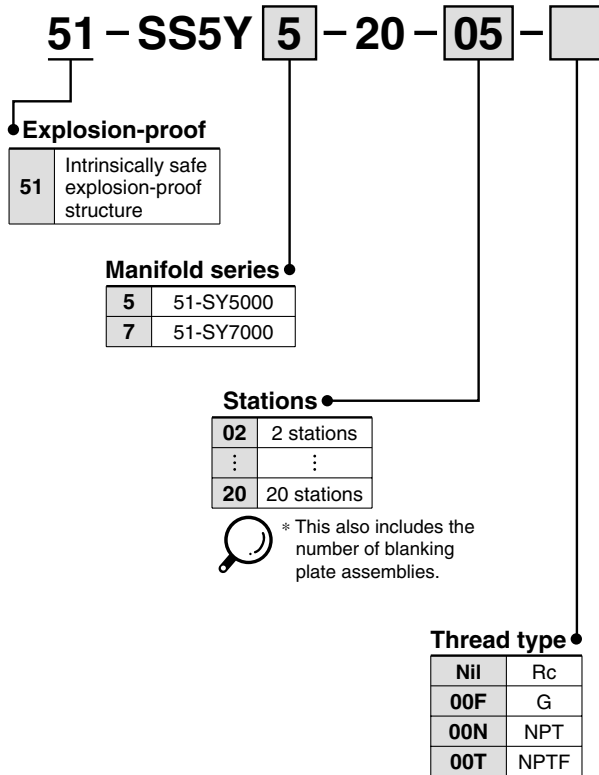

How to Order Valve Manifold Assembly

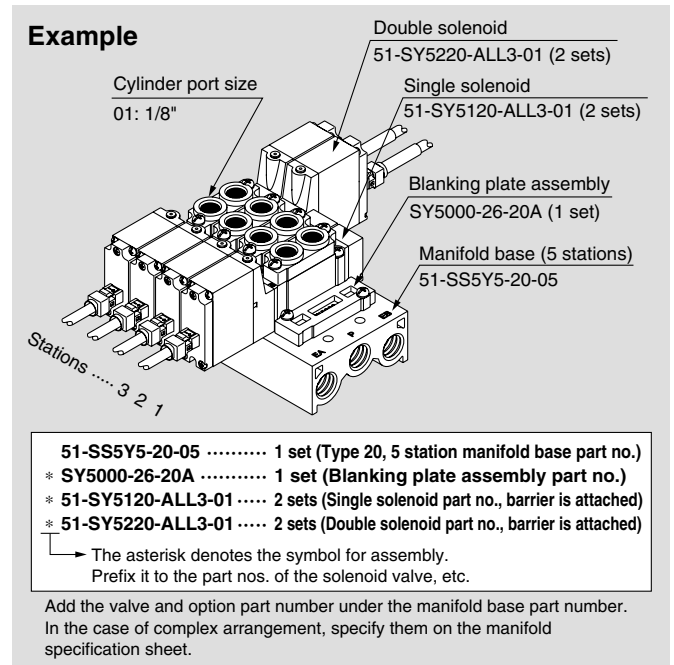

How to Order Valve

51-SY 5 1 20-A LL 3 - 01

Explosion-proof

51	Intrinsically safe explosion-proof structure
-----------	--

Series

5	51-SY5000
7	51-SY7000

Type of actuation

1	2-position single
2	2-position double
3	3-position closed center
4	3-position exhaust center
5	3-position pressure center

Barrier designation Note 1) Note 2)

Nil	Without barrier
A	Z728.H
F	KFD0-SD2-Ex1.1065

Note 1) Attached barrier type

Note 2) Contact Pepperl+Fuchs for details on the barrier specifications.

Thread type

Nil	Rc
F	G
N	NPT
T	NPTF

A, B port size

Thread piping

Symbol	Port size	Applicable series
01	1/8	51-SY5000
02	1/4	51-SY7000

One-touch fitting

Symbol	Port size	Applicable series
C4	ø4 one-touch fitting	51-SY5000
C6	ø6 one-touch fitting	
C8	ø8 one-touch fitting	
C8	ø8 one-touch fitting	51-SY7000
C10	ø10 one-touch fitting	

Warning If a resin tube is used, take measures against static electricity.

Manual override

Nil	Non-locking push type
D	Push-turn locking slotted type
E	Push-turn locking lever type

Electrical entry

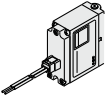
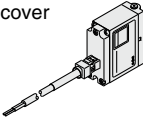
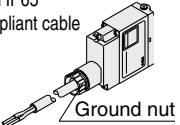
Symbol	Electrical entry
L	L-type plug connector 
LL	L-type plug connector with cover 
TT <small>Note)</small>	With IP65 compliant cable  Ground nut

Note) TT-type is connected to the terminal block.

Cables other than the connected one cannot be used.

Lead wire length

Symbol	Lead wire length	Note
3	300 mm	—
6	600 mm	Maximum length 600 mm for L-type
10	1000 mm	—
15	1500 mm	—
20	2000 mm	—
30	3000 mm	—
100	10000 mm	Semi-standard



Note) When placing an order for body ported solenoid valve as a single unit, mounting screws and a gasket for manifold are not attached. Order them separately, if necessary. (For details, refer to page 32.)

Series 51-SY5000/7000

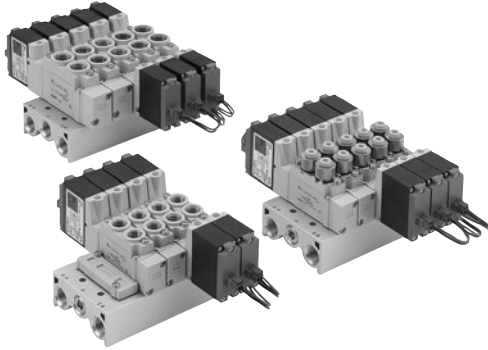

Manifold Specifications

Model		51-SS5Y5-20	51-SS5Y7-20
Applicable valve		51-SY5□20	51-SY7□20
Manifold type		Single base B mount	
P (SUP)/R (EXH)		Common SUP/EXH	
Valve stations		2 to 20 stations ^{Note 1)}	
A, B port location		Valve	
Port size	P, EA, EB port	1/4	
	A, B port	1/8 C4 (ø4 one-touch fitting) C6 (ø6 one-touch fitting) C8 (ø8 one-touch fitting)	1/4 C8 (ø8 one-touch fitting) C10 (ø10 one-touch fitting)
Manifold base mass W (g) n: Stations		W = 36n + 64	W = 43n + 64

 Note 1) For 10 stations or more (5 stations or more for the 51-SS5Y7), supply pressure to P port on both sides and exhaust from EA/EB port on both sides.

Note 2) Refer to "Manifold Options" on page 32.

 **Warning** If a resin tube is used, take measures against static electricity.

Flow-rate Characteristics

Model	Port size		Flow-rate characteristics					
	1, 5, 3 (P, EA, EB)	4, 2 (A, B)	1→4/2 (P→A/B)			4/2→5/3 (A/B→EA/EB)		
			C [dm ³ /(s·bar)]	b	Cv	C [dm ³ /(s·bar)]	b	Cv
51-SS5Y5-20	1/4	C8	1.9	0.28	0.48	2.2	0.20	0.53
51-SS5Y7-20	1/4	C10	3.6	0.31	0.93	3.6	0.27	0.88

 Note) The value is for manifold base with 5 stations and individually operated 2-position type.

Dimensions: 51-SY5000

L-type plug connector (L)

51-SS5Y5-20-Stations-

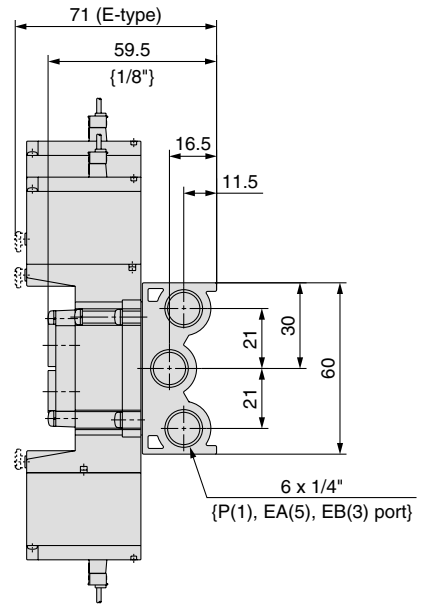
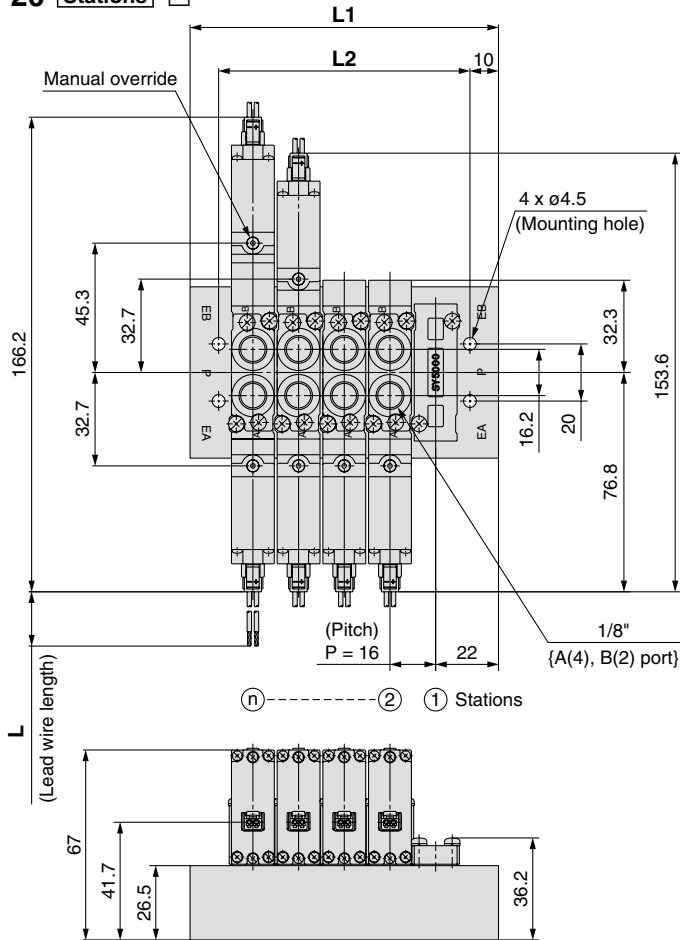

L-type plug connector with cover (LL)

51-SS5Y5-20-Stations-

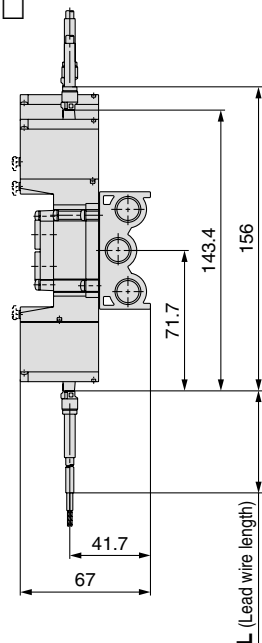

With IP65 compliant cable (TT)

51-SS5Y5-20-Stations-

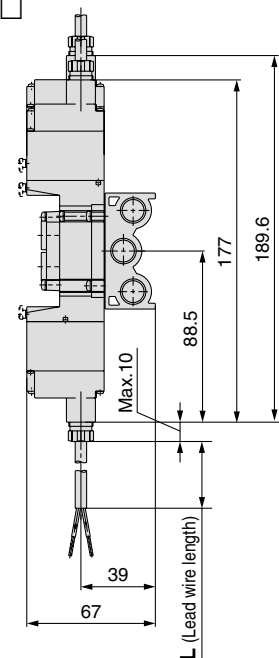

Stations n	2 stations	3 stations	4 stations	5 stations	6 stations	7 stations	8 stations	9 stations	10 stations	11 stations	12 stations	13 stations	14 stations	15 stations	16 stations	17 stations	18 stations	19 stations	20 stations
L1	60	76	92	108	124	140	156	172	188	204	220	236	252	268	284	300	316	332	348
L2	40	56	72	88	104	120	136	152	168	184	200	216	232	248	264	280	296	312	328

Series 51-SY5000/7000

Dimensions: 51-SY7000

L-type plug connector (L)

51-SS5Y7-20-Stations-

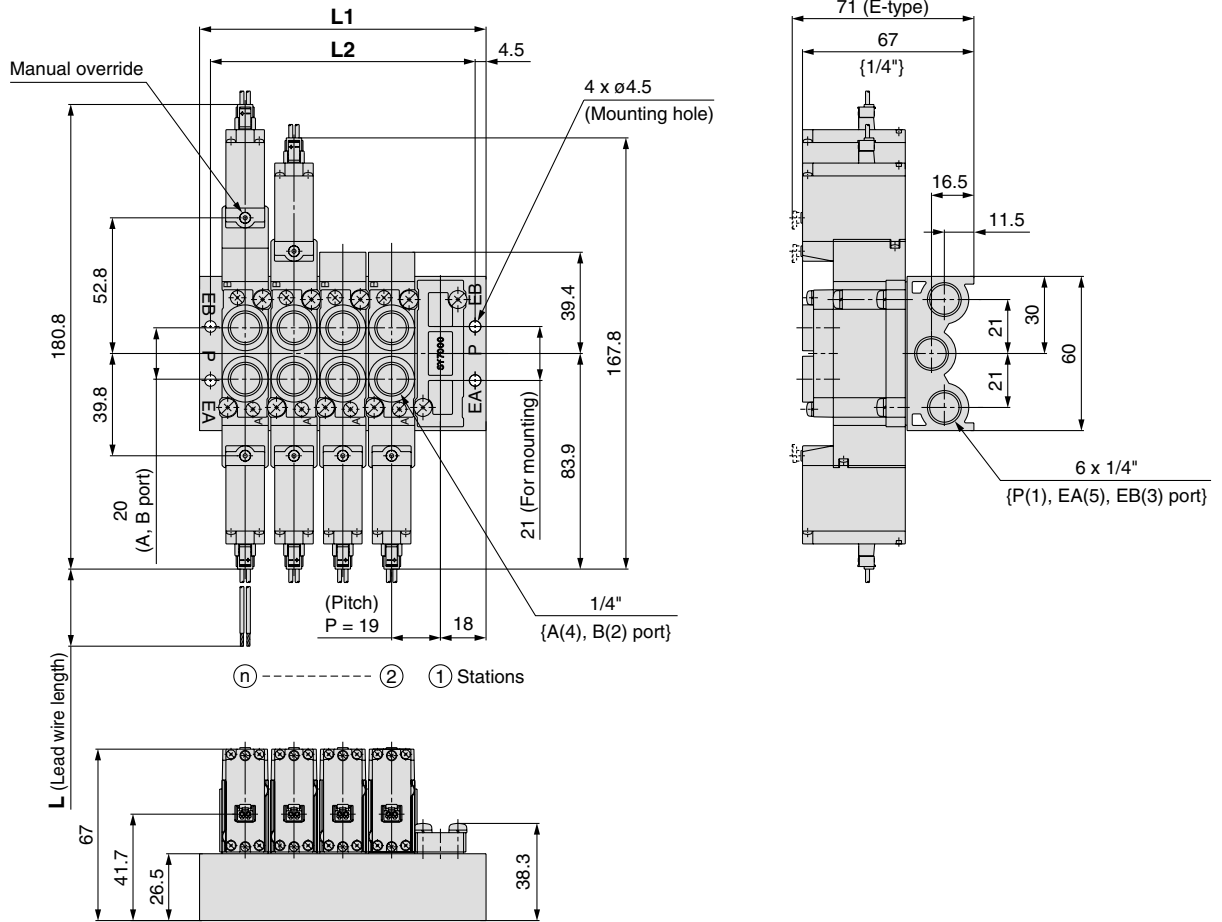

L-type plug connector with cover (LL)

51-SS5Y7-20-Stations-

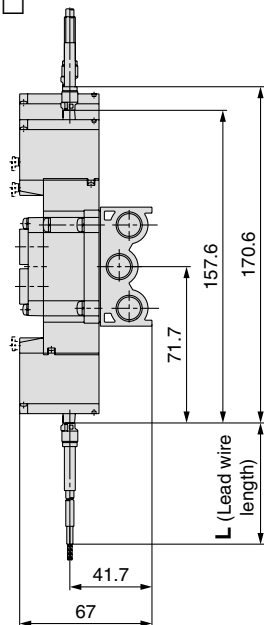

With IP65 compliant cable (TT)

51-SS5Y7-20-Stations-

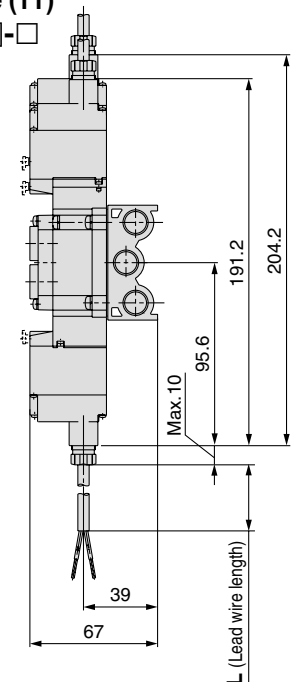

Stations n	2 stations	3 stations	4 stations	5 stations	6 stations	7 stations	8 stations	9 stations	10 stations	11 stations	12 stations	13 stations	14 stations	15 stations	16 stations	17 stations	18 stations	19 stations	20 stations
L1	55	74	93	112	131	150	169	188	207	226	245	264	283	302	321	340	359	378	397
L2	46	65	84	103	122	141	160	179	198	217	236	255	274	293	312	331	350	369	388

Manifold Options

■ Type 20 Blanking Plate Assembly

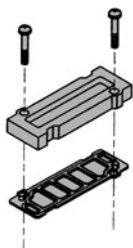

Series	Assembly part no.
51-SY5000	SY5000-26-20A
51-SY7000	SY7000-26-22A

■ Gasket Assembly Part No.

Round head combination screw

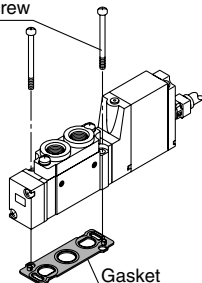

Series	Gasket assembly
51-SY5000	SY5000-GS-1
51-SY7000	SY7000-GS-1

Note) Gasket assembly consists of 10 sets of mounting screws and a gasket.

■ Individual SUP Spacer Assembly

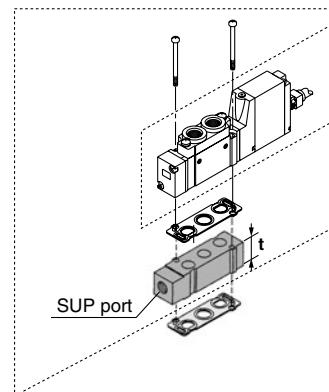

Series	Assembly part no.	Port size	t
51-SY5000	SY5000-38-1*A	1/8	15
51-SY7000	SY7000-38-1*A	1/4	18

Note) The SUP port of the 51-SY5000/7000 may be either on the lead wire side or on the end plate side. (An assembly is shipped under the conditions shown in the figure.)

■ Individual EXH Spacer Assembly

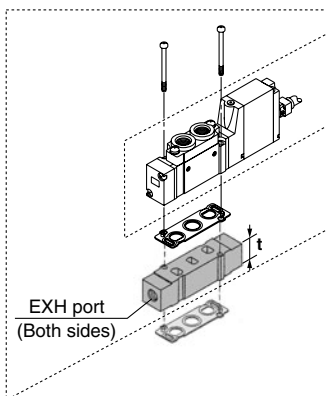

Series	Assembly part no.	Port size	t
51-SY5000	SY5000-39-1*A	1/8	15
51-SY7000	SY7000-39-1*A	1/4	18

■ Individual SUP Spacer Assembly + Individual EXH Spacer Assembly (Double spacer)

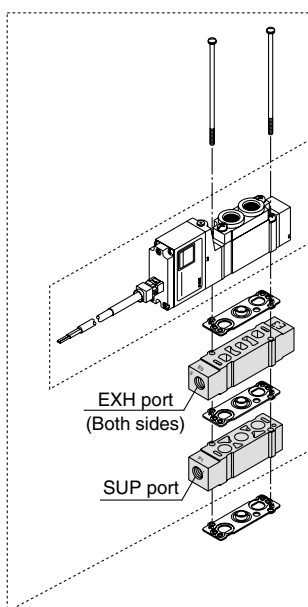

Series	Individual SUP + Individual EXH assembly part no.	Port size	Applicable manifold type
51-SY5000	SY5000-75-2*A	1/8	Type 20
51-SY7000	SY7000-73-3*A	1/4	

Note) The SUP spacer's port does not have an orientation. As for the EXH ports, adjust the symbol "5" to the pilot valve side. Also, please make sure to connect the individual ports to protect the wiring section of the pilot valve from drainage, etc. The individual SUP spacer and EXH spacer can be mounted either on the upper side or lower side. (The above illustration shows the condition when the product is shipped out from a factory already assembled.)

⚠ Caution

Mounting screw tightening torques

M3: 0.8 N·m
M4: 1.4 N·m

* Thread type

Nil	Rc
F	G
N	NPT
T	NPTF

⚠ Warning

When mounting a valve or spacer on the manifold base or sub-plate, etc., those mounting directions are determined. If mounted in the wrong direction, the equipment to be connected may cause malfunction. Refer to external dimensions, and then mount it.

Type **41**

Type **42**

Intrinsically Safe Explosion-proof System

5 Port Solenoid Valve

Series 51-SY5000/7000

Base Mounted Manifold

Bar Stock Type

How to Order Manifold

Type 41/Compact Type

51-SS5Y 5-41-05-01 □

Explosion-proof

51 Intrinsically safe explosion-proof structure

Manifold series

5 51-SY5000

Stations

02	2 stations
⋮	⋮
20	20 stations

* This also includes the number of blanking plate assemblies.

A, B port size

Thread piping

Symbol	Port size	Applicable series
01	1/8	51-SY5000

One-touch fitting (Metric size)

Symbol	Port size	Applicable series
C6	ø6 one-touch fitting	51-SY5000
C8	ø8 one-touch fitting	

One-touch fitting (Inch size)

Symbol	Port size	Applicable series
N7	ø1/4" one-touch fitting	51-SY5000
N9	ø5/16" one-touch fitting	

Thread type

Nil	Rc
F	G
N	NPT
T	NPTF

Type 42/External Pilot Capable

51-SS5Y 5-42-05-02 □

Explosion-proof

51 Intrinsically safe explosion-proof structure

Manifold series

5 51-SY5000

Stations

02	2 stations
⋮	⋮
20	20 stations

A, B port size

Thread piping

Symbol	Port size	Applicable series
02	1/4	51-SY5000 51-SY7000

One-touch fitting (Metric size)

Symbol	Port size	Applicable series
C6	ø6 one-touch fitting	51-SY5000
C8	ø8 one-touch fitting	
C10	ø10 one-touch fitting	51-SY7000

One-touch fitting (Inch size)

Symbol	Port size	Applicable series
N7	ø1/4" one-touch fitting	51-SY5000
N9	ø5/16" one-touch fitting	
N11	ø3/8" one-touch fitting	51-SY7000

Thread type

Nil	Rc
F	G
N	NPT
T	NPTF

Warning If a resin tube is used, take measures against static electricity.

How to Order Valve Manifold Assembly

Example

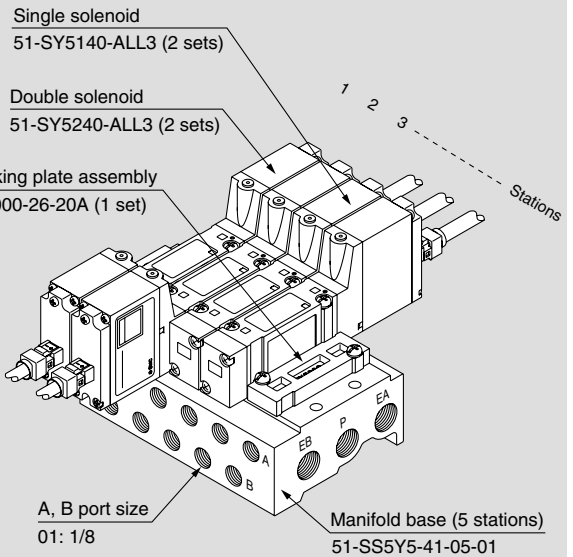

- 51-SS5Y5-41-05-01 1 set (Type 41, 5 station manifold base part no.)
- * 51-SY5240-ALL3 2 sets (Double solenoid part no., barrier is attached)
- * 51-SY5140-ALL3 2 sets (Single solenoid part no., barrier is attached)
- * SY5000-26-20A 1 set (Blanking plate assembly part no.)

→ The asterisk denotes the symbol for assembly. Prefix it to the part nos. of the solenoid valve, etc.

Add the valve and option part number under the manifold base part number. In the case of complex arrangement, specify them on the manifold specification sheet.

How to Order Valve

51-SY 5 2 40 - A LL 3

Explosion-proof

51	Intrinsically safe explosion-proof structure
-----------	--

Series

5	51-SY5000
7	51-SY7000

Type of actuation

1	2-position single
2	2-position double
3	3-position closed center
4	3-position exhaust center
5	3-position pressure center

Pilot type

Nil	Internal pilot
R	External pilot

Barrier designation Note 1) Note 2)

Nil	Without barrier
A	Z728.H
F	KFD0-SD2-Ex1.1065

Note 1) Attached barrier type
 Note 2) Contact Pepperl+Fuchs for details on the barrier specifications.

Manual override

Nil	Non-locking push type
D	Push-turn locking slotted type
E	Push-turn locking lever type

Lead wire length

Symbol	Lead wire length	Note
3	300 mm	—
6	600 mm	Maximum length 600 mm for L-type
10	1000 mm	—
15	1500 mm	—
20	2000 mm	—
30	3000 mm	—
100	10000 mm	Semi-standard

Electrical entry

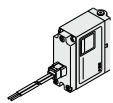
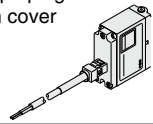
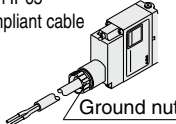
Symbol	Electrical entry
L	L-type plug connector 
LL	L-type plug connector with cover 
TT <small>Note)</small>	With IP65 compliant cable  Ground nut

Note) TT-type is connected to the terminal block.
 Cables other than the connected one cannot be used.

Series 51-SY5000/7000

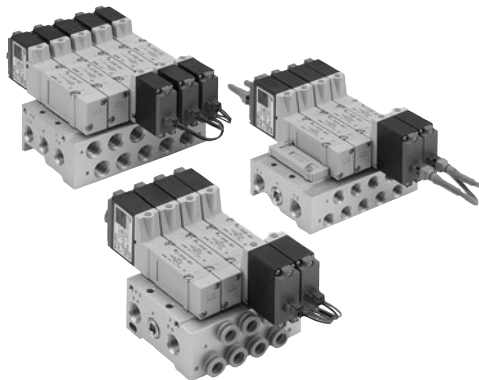

Manifold Specifications

Model		51-SS5Y5-41	51-SS5Y5-42	51-SS5Y7-42
Applicable valve		51-SY5□40		51-SY7□40
Manifold type		Single base B mount		
P (SUP)/R (EXH)		Common SUP/EXH		
Valve stations		2 to 20 stations ^{Note 1)}		
A, B port location		Location	Base	
		Direction	Side	
P, EA, EB port		1/4		
Port size	P, EA, EB port	1/4		
	A, B port	1/8 C6 (ø6 one-touch fitting) C8 (ø8 one-touch fitting)	1/4 C6 (ø6 one-touch fitting) C8 (ø8 one-touch fitting)	1/4 C10 (ø10 one-touch fitting)
Manifold base mass W (g) n: Stations		W = 61n + 101	W = 79n + 127	W = 100n + 151

 Note 1) For 10 stations or more (5 stations or more for the 51-SS5Y7), supply pressure to P port on both sides and exhaust from EA/EB port on both sides.
Note 2) Refer to "Manifold Options" on page 39.

Flow-rate Characteristics

Model	Port size		Flow-rate characteristics					
	1, 5, 3 (P, EA, EB)	4, 2 (A, B)	1→4/2 (P→A/B)			4/2→5/3 (A/B→EA/EB)		
			C [dm ³ /(s·bar)]	b	Cv	C [dm ³ /(s·bar)]	b	Cv
51-SS5Y5-41	1/4	C8	1.8	0.23	0.44	1.9	0.16	0.45
51-SS5Y5-42	1/4	C8	1.9	0.20	0.46	1.9	0.12	0.43
51-SS5Y7-42	1/4	C10	3.0	0.25	0.75	3.0	0.12	0.66

 Note) The value is for manifold base with 5 stations and individually operated 2-position type.

Dimensions: 51-SY5000

L-type plug connector (L)

51-SS5Y5-41-Stations-□□

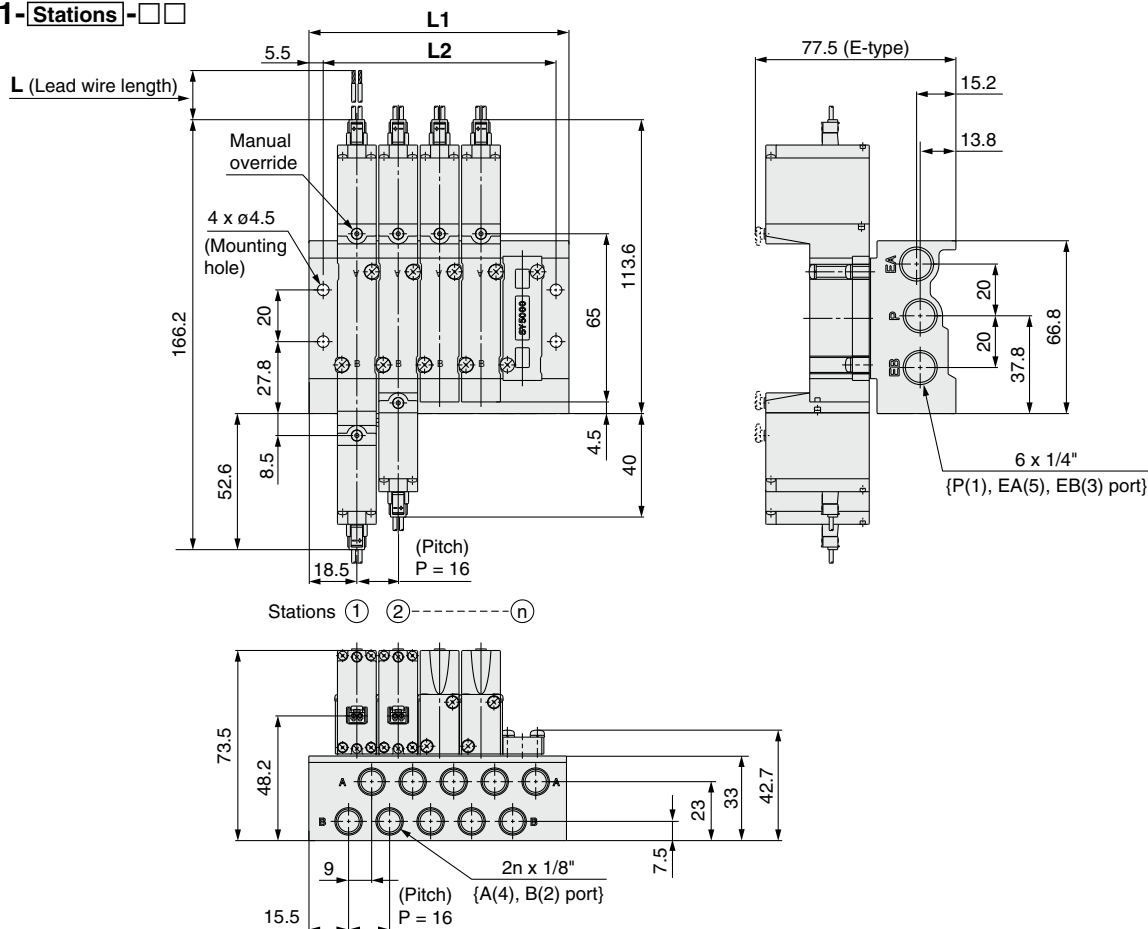

L-type plug connector with cover (LL)

51-SS5Y5-41-Stations-□□

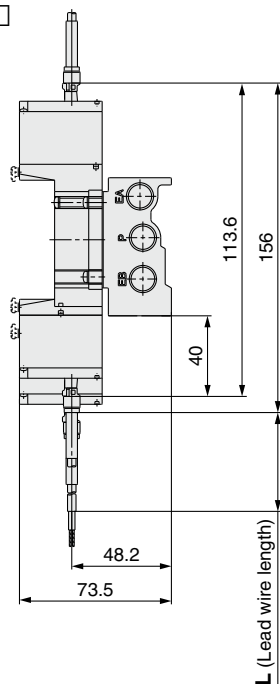

With IP65 compliant cable (TT)

51-SS5Y5-41-Stations-□□

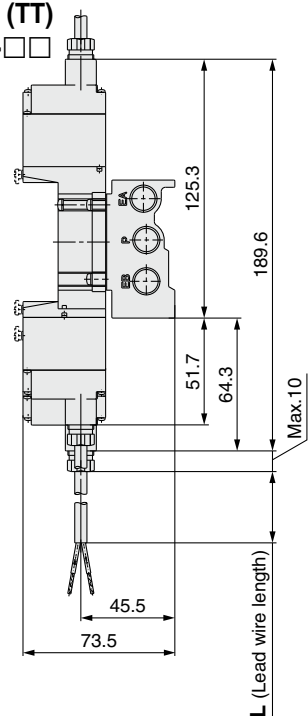

Stations n	2 stations	3 stations	4 stations	5 stations	6 stations	7 stations	8 stations	9 stations	10 stations	11 stations	12 stations	13 stations	14 stations	15 stations	16 stations	17 stations	18 stations	19 stations	20 stations
L1	52.5	68.5	84.5	100.5	116.5	132.5	148.5	164.5	180.5	196.5	212.5	228.5	244.5	260.5	276.5	292.5	308.5	324.5	340.5
L2	42	58	74	90	106	122	138	154	170	186	202	218	234	250	266	282	298	314	330

Series 51-SY5000/7000

Dimensions: 51-SY5000

L-type plug connector (L)

51-SS5Y5-42-Stations-

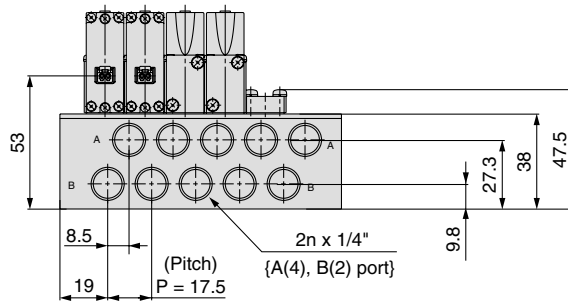
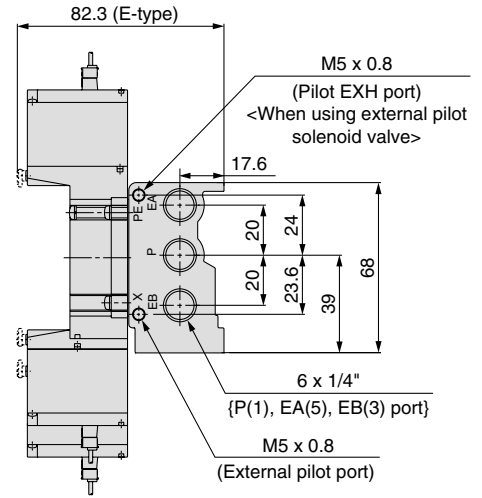
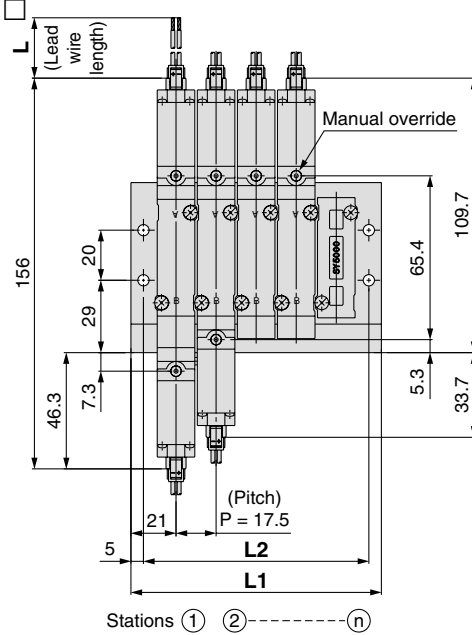

L-type plug connector with cover (LL)

51-SS5Y5-42-Stations-

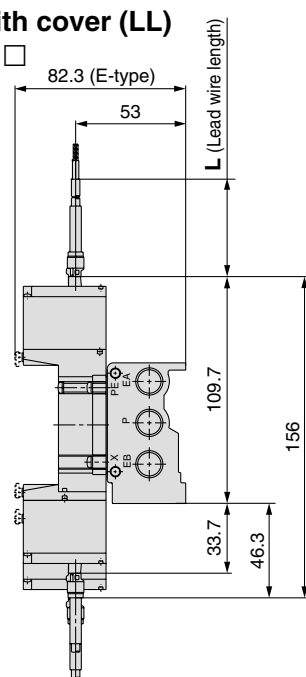

With IP65 compliant cable (TT)

51-SS5Y5-42-Stations-

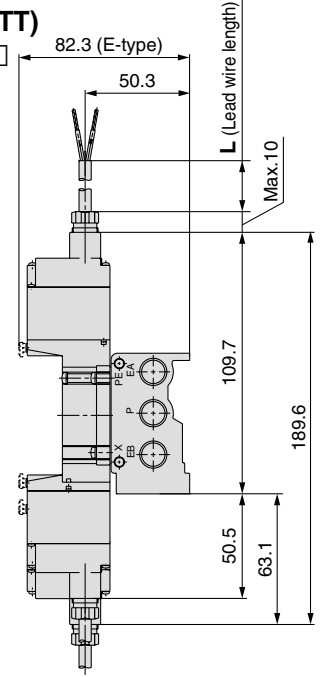

Stations n	2 stations	3 stations	4 stations	5 stations	6 stations	7 stations	8 stations	9 stations	10 stations	11 stations	12 stations	13 stations	14 stations	15 stations	16 stations	17 stations	18 stations	19 stations	20 stations
L1	59.5	77	94.5	112	129.5	147	164.5	182	199.5	217	234.5	252	269.5	287	304.5	322	339.5	357	374.5
L2	49.5	67	84.5	102	119.5	137	154.5	172	189.5	207	224.5	242	259.5	277	294.5	312	329.5	347	364.5

Dimensions: 51-SY7000

L-type plug connector (L)

51-SS5Y7-42-Stations-

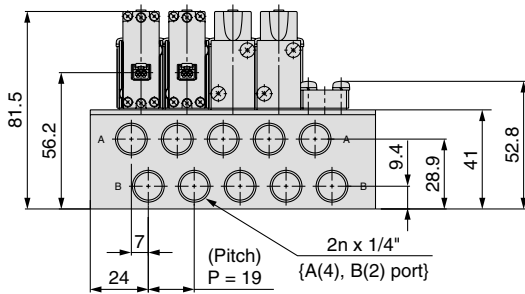
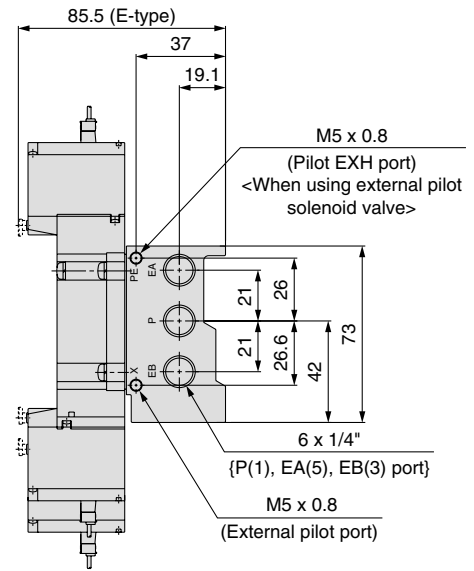
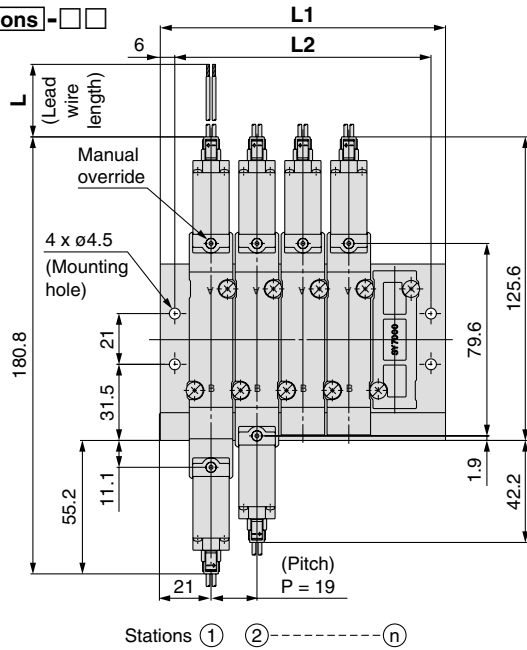

L-type plug connector with cover (LL)

51-SS5Y7-42-Stations-

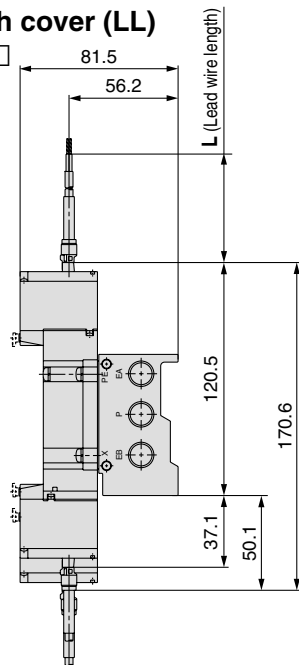

With IP65 compliant cable (TT)

51-SS5Y7-42-Stations-

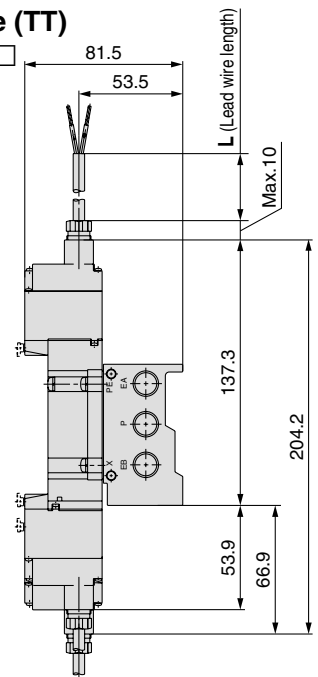

Stations n	2 stations	3 stations	4 stations	5 stations	6 stations	7 stations	8 stations	9 stations	10 stations	11 stations	12 stations	13 stations	14 stations	15 stations	16 stations	17 stations	18 stations	19 stations	20 stations
L1	61	80	99	118	137	156	175	194	213	232	251	270	289	308	327	346	365	384	403
L2	49	68	87	106	125	144	163	182	201	220	239	258	277	296	315	334	353	372	391

Series 51-SY5000/7000

Manifold Options

■ Type 41, 42 Blanking Plate Assembly

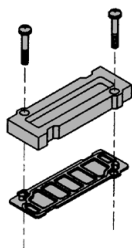

Series	Assembly part no.
51-SY5000	SY5000-26-20A
51-SY7000	SY7000-26-22A

■ Gasket Assembly Part No.

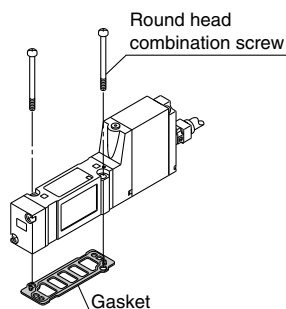

Series	Gasket assembly
51-SY5000	SY5000-GS-2
51-SY7000	SY7000-GS-2

Note) Gasket assembly consists of 10 sets of mounting screws and a gasket.

■ Individual SUP Spacer Assembly

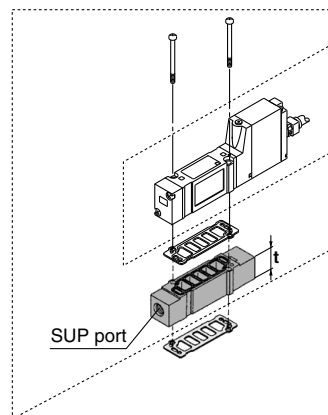

Series	Assembly part no.	Port size	t
51-SY5000	SY5000-38-16*A	1/8	15
51-SY7000	SY7000-38-16*A	1/4	18

Note) The SUP port of the 51-SY5000/7000 may be either on the lead wire side or on the end plate side. (An assembly is shipped under the conditions shown in the figure.)

■ Individual EXH Spacer Assembly

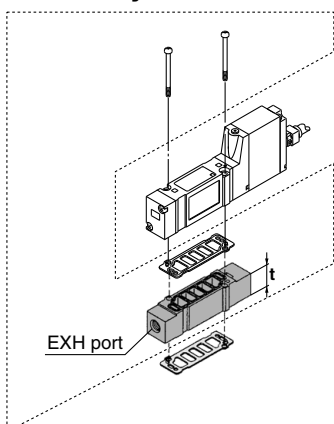

Series	Assembly part no.	Port size	t
51-SY5000	SY5000-39-16*A	1/8	15
51-SY7000	SY7000-39-16*A	1/4	18

■ Individual SUP Spacer Assembly + Individual EXH Spacer Assembly (Double spacer)

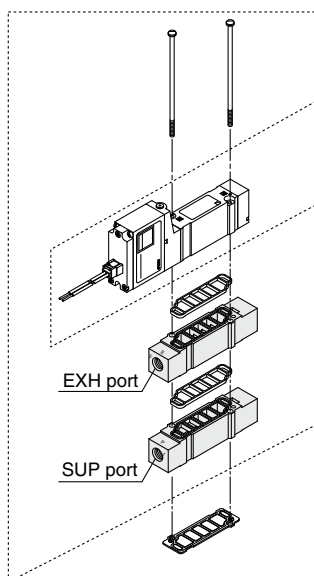

Series	Individual SUP + Individual EXH assembly part no.	Port size
51-SY5000	SY5000-75-1*A	1/8
51-SY7000	SY7000-73-1*A	1/4

Note) The port on a spacer can be directed to the pilot valve side or end plate side. For mounting the port to the pilot valve side, please make sure to connect the ports to protect the pilot valve wiring section from drainage. The individual SUP spacer and EXH spacer can be mounted either on the upper side or lower side. (The above illustration shows the condition when the product is shipped out from a factory already assembled.)

⚠ Caution

Mounting screw tightening torques

M3: 0.8 N·m
M4: 1.4 N·m

* Thread type

Nil	Rc
F	G
N	NPT
T	NPTF

⚠ Warning

When mounting a valve or spacer on the manifold base or sub-plate, etc., those mounting directions are determined. If mounted in the wrong direction, the equipment to be connected may cause malfunction. Refer to external dimensions, and then mount it.



Safety Instructions

These safety instructions are intended to prevent hazardous situations and/or equipment damage. These instructions indicate the level of potential hazard with the labels of “**Caution,**” “**Warning**” or “**Danger.**” They are all important notes for safety and must be followed in addition to International Standards (ISO/IEC)*1), and other safety regulations.

*1) ISO 4414: Pneumatic fluid power – General rules relating to systems.
ISO 4413: Hydraulic fluid power – General rules relating to systems.
IEC 60204-1: Safety of machinery – Electrical equipment of machines. (Part 1: General requirements)
ISO 10218-1: Manipulating industrial robots - Safety.
etc.

- | | |
|--|---|
| | Caution: Caution indicates a hazard with a low level of risk which, if not avoided, could result in minor or moderate injury. |
| | Warning: Warning indicates a hazard with a medium level of risk which, if not avoided, could result in death or serious injury. |
| | Danger : Danger indicates a hazard with a high level of risk which, if not avoided, will result in death or serious injury. |

Warning

1. The compatibility of the product is the responsibility of the person who designs the equipment or decides its specifications.

Since the product specified here is used under various operating conditions, its compatibility with specific equipment must be decided by the person who designs the equipment or decides its specifications based on necessary analysis and test results. The expected performance and safety assurance of the equipment will be the responsibility of the person who has determined its compatibility with the product. This person should also continuously review all specifications of the product referring to its latest catalog information, with a view to giving due consideration to any possibility of equipment failure when configuring the equipment.

2. Only personnel with appropriate training should operate machinery and equipment.

The product specified here may become unsafe if handled incorrectly. The assembly, operation and maintenance of machines or equipment including our products must be performed by an operator who is appropriately trained and experienced.

3. Do not service or attempt to remove product and machinery/equipment until safety is confirmed.

1. The inspection and maintenance of machinery/equipment should only be performed after measures to prevent falling or runaway of the driven objects have been confirmed.
2. When the product is to be removed, confirm that the safety measures as mentioned above are implemented and the power from any appropriate source is cut, and read and understand the specific product precautions of all relevant products carefully.
3. Before machinery/equipment is restarted, take measures to prevent unexpected operation and malfunction.

4. Contact SMC beforehand and take special consideration of safety measures if the product is to be used in any of the following conditions.

1. Conditions and environments outside of the given specifications, or use outdoors or in a place exposed to direct sunlight.
2. Installation on equipment in conjunction with atomic energy, railways, air navigation, space, shipping, vehicles, military, medical treatment, combustion and recreation, or equipment in contact with food and beverages, emergency stop circuits, clutch and brake circuits in press applications, safety equipment or other applications unsuitable for the standard specifications described in the product catalog.
3. An application which could have negative effects on people, property, or animals requiring special safety analysis.
4. Use in an interlock circuit, which requires the provision of double interlock for possible failure by using a mechanical protective function, and periodical checks to confirm proper operation.



Safety Instructions

Caution

1. The product is provided for use in manufacturing industries.

The product herein described is basically provided for peaceful use in manufacturing industries.

If considering using the product in other industries, consult SMC beforehand and exchange specifications or a contract if necessary.

If anything is unclear, contact your nearest sales branch.

Limited warranty and Disclaimer/Compliance Requirements

The product used is subject to the following “Limited warranty and Disclaimer” and “Compliance Requirements”. Read and accept them before using the product.

Limited warranty and Disclaimer

1. The warranty period of the product is 1 year in service or 1.5 years after the product is delivered.*2)

Also, the product may have specified durability, running distance or replacement parts. Please consult your nearest sales branch.

2. For any failure or damage reported within the warranty period which is clearly our responsibility, a replacement product or necessary parts will be provided.

This limited warranty applies only to our product independently, and not to any other damage incurred due to the failure of the product.

3. Prior to using SMC products, please read and understand the warranty terms and disclaimers noted in the specified catalog for the particular products.

***2) Vacuum pads are excluded from this 1 year warranty.**

A vacuum pad is a consumable part, so it is warranted for a year after it is delivered.

Also, even within the warranty period, the wear of a product due to the use of the vacuum pad or failure due to the deterioration of rubber material are not covered by the limited warranty.

Compliance Requirements

1. The use of SMC products with production equipment for the manufacture of weapons of mass destruction (WMD) or any other weapon is strictly prohibited.

2. The exports of SMC products or technology from one country to another are governed by the relevant security laws and regulations of the countries involved in the transaction. Prior to the shipment of a SMC product to another country, assure that all local rules governing that export are known and followed.



Series 51-SY5000/7000/9000 Specific Product Precautions 1

Be sure to read this before handling the products. For safety instructions and 3/4/5-port solenoid valve precautions, refer to the “Handling Precautions for SMC Products” and the “Operation Manual” on the SMC website: <https://www.smcworld.com>

Manual Override

Warning

Non-locking push type [Standard]

Press in the direction of the arrow.

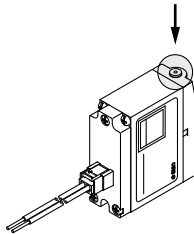

Push-turn locking slotted type [Type D]

While pressing, turn in the direction of the arrow.

If it is not turned, it can be operated the same way as the non-locking type.

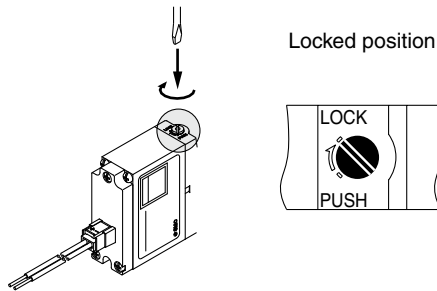

Caution

When operating the locking type D with a screwdriver, turn it gently using a watchmaker's screwdriver. [Torque: Less than 0.1 N·m]

Push-turn locking lever type [Type E]

While pressing, turn it the direction of the arrow.

If it is not turned, it can be operated the same way as the non-locking type.

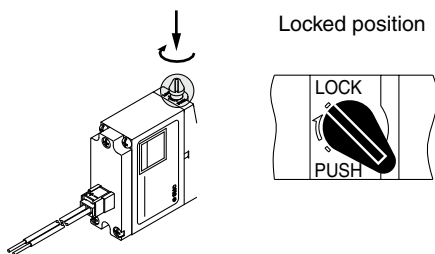

Caution

When locking the manual override on the push-turn locking types (D, E), be sure to push it down before turning. Turning without first pushing it down can cause damage to the manual override and trouble such as air leakage, etc.

Exhaust Side

Caution

The 51-SY series pilot valve and main valve share a common exhaust inside the valve. Therefore, do not block the exhaust port when arranging the piping.

Series 51-SY5000/7000/9000 Used as a 3-Port Valve

Caution

In case of using a 5-port valve as a 3-port valve

The 51-SY5000/7000/9000 series can be used as normally closed (N.C.) or normally open (N.O.) 3-port port valves by closing one of the cylinder ports (A or B) with a plug. However, they should be used with the exhaust ports kept open.

Plug position		B port	A port
Type of actuation		N.C.	N.O.
Number of solenoids	Single	<p>Plug (A) (B) 5 1 3 (EA) (P) (EB)</p>	<p>Plug (A) (B) 5 1 3 (EA) (P) (EB)</p>
	Double	<p>Plug (A) (B) 5 1 3 (EA) (P) (EB)</p>	<p>Plug (A) (B) 5 1 3 (EA) (P) (EB)</p>

How to Use Plug Connector

Caution

1. Attaching and detaching connectors

- To attach a connector, hold the lever and connector unit between your fingers and insert straight onto the pins of the solenoid valve so that the lever's pawl is pushed into the groove and locks.
- To detach a connector, remove the pawl from the groove by pushing the lever downward with your thumb, and pull the connector straight out.

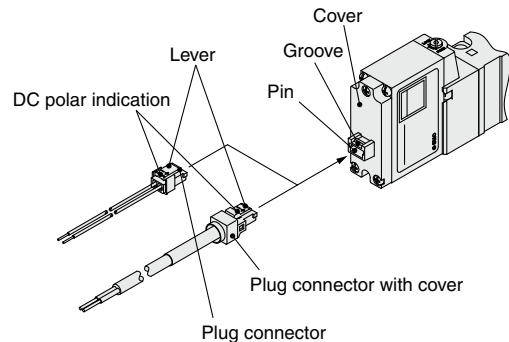



Series 51-SY5000/7000/9000

Specific Product Precautions 4

Be sure to read this before handling the products. For safety instructions and 3/4/5-port solenoid valve precautions, refer to the “Handling Precautions for SMC Products” and the “Operation Manual” on the SMC website: <https://www.smcworld.com>

One-touch Fittings

Warning

1. Please take antistatic precautions appropriate to the use of resin tubing.

Refer to “Recommended Practices for Explosion-Protected Electrical Installations in General Industries” issued by Technology Institution of Industrial Safety.

Caution

The pitch determined for each of the 51-SY series piping ports (P, A, B, etc.) is based on the assumption that KJ series one-touch fittings will be used.

For this reason, other pipe fittings may interfere with each other depending on their type and size. Dimensions should be confirmed in a pipe fitting catalog before they are used.

• Tubing attachment/detachment for one-touch fittings

1) Attaching of tubing

1. Take a tubing having no flaws on its periphery and cut it off at a right angle. When cutting the tubing, use tubing cutters TK-1, 2 or 3. Do not use pinchers, nippers or scissors, etc. If cutting is done with tools other than tubing cutters, the tubing may be cut diagonally or become flattened, etc., making a secure installation impossible, and causing problems such as the tubing pulling out after installation or air leakage. Allow some extra length in the tubing.
2. Grasp the tubing and push it in slowly, inserting it securely all the way into the fitting.
3. After inserting the tubing, pull on it lightly to confirm that it will not come out. If it is not installed securely all the way into the fitting, this can cause problems such as air leakage or the tubing pulling out.

2) Detaching of tubing

1. Push in the release button sufficiently, pushing its collar equally around the circumference.
 2. Pull out the tubing while holding down the release button so that it does not come out. If the release button is not pressed down sufficiently, there will be increased bite on the tubing and it will become more difficult to pull it out.
 3. When the removed tubing is to be used again, cut off the portion which has been chewed before reusing it. If the chewed portion of the tubing is used as is, this can cause trouble such as air leakage or difficulty in removing the tubing.
- The pitch determined for each of the 51-SY series piping ports (A, B, etc.) is based on the assumption that KJ series one-touch fittings will be used. For this reason, other pipe fittings may interfere with each other depending on their type and size. Dimensions should be confirmed in a pipe fitting catalog before they are used.

Other Tubing Brands

Caution

1. When using other than SMC brand tubing, confirm that the following specifications are satisfied with respect to the outside diameter tolerance of the tubing.

- | | |
|------------------------|-------------------------------------|
| 1) Nylon tubing | within ±0.1 mm |
| 2) Soft nylon tubing | within ±0.1 mm |
| 3) Polyurethane tubing | within +0.15 mm,
within -0.2 mm. |

Do not use tubing which do not meet these outside diameter tolerances. It may not be possible to connect them, or they may cause other trouble, such as air leakage or the tubing pulling out after connection.

Solenoid Valve Mounting

Caution

Mount it so that there is no slippage or deformation in gaskets, and tighten with the tightening torque as shown below.

Model	Thread size	Tightening torque
51-SY5000	M3	0.8 N·m
51-SY7000	M4	1.4 N·m
51-SY9000	M3	0.8 N·m



Series 51-SY5000/7000/9000

Specific Product Precautions 5

Be sure to read this before handling the products. For safety instructions and 3/4/5-port solenoid valve precautions, refer to the "Handling Precautions for SMC Products" and the "Operation Manual" on the SMC website: <https://www.smcworld.com>

Valve Selection for Hazardous Environment

Warning

The explosion-proof performance of the 51-SY (intrinsically safe explosion-proof) is Ex ia IIC T5 (See the reference "Explosion-proof Structure Symbol (Ex ia IIC T5)"). Selection of a valve for a dangerous place should be done in accordance with "Recommended Practices for Explosion-Protected Electrical Installations in General Industries" issued by Technology Institution of Industrial Safety.

Classification of Hazardous Environment

Warning

This valve should be used in a class-1 or class-2 environment by combining with a barrier (placed in non-hazardous location).

Note that this valve can not be used in a class-0 environment.

Classification of hazardous environment

■ Class-0 environment Not available

A place where an explosive atmosphere is constantly generated or can be generated.

Also, a place where atmosphere is above the lower limit of explosion constantly or for a long time of period is also regarded as the class-0 environment for safety season.

(Places often falling into the class-0 environment)

- a) A container of flammable liquid or space above the liquid level in the container.
- b) Around the liquid level of flammable liquid in an open container or similar place.

■ Class-1 environment Available

A place where an explosive atmosphere can be generated periodically or occasionally.

Also, a place which can have a dangerous concentration of explosive gas due to repair, maintenance, or leakage.

(Places often falling into the class-1 environment)

- a) Around an opening which releases explosive gas due to removal of a product during normal operation, opening/closing of a lid, or operation of a safety valve.
- b) Around the opening of a container such as a tanker and drum which is filled with flammable liquid.
- c) Around an opening which releases explosive gas due to occasional operation of a relief valve.
- d) Around the opening of a gas-vent on a tank etc.
- e) Around an opening which releases explosive gas during inspection or repair work.
- f) A room or a place which can have explosive gas due to insufficient ventilation.
- g) The part which is above the roof of a floating roof tank but within the shell.
- h) A place which can have leaked explosive gas and can accumulate the gas such as a pit.

■ Class-2 environment Available

A place where explosive atmosphere can be generated under abnormal condition though an explosive atmosphere cannot be generated under normal condition.

- 1) A place where flammable gas is constantly operated, but it is enclosed in an air-tight container or facility, and concentration of the gas may be thick when the container or facility gets broken due to an accident or when operation fails.
- 2) A place that can have a dangerous explosive gas concentration due to the breakage of mechanical ventilation equipment though the equipment is usually reliable.

(Places often falling into the class-2 environment)

- a) A place where dangerous gas or liquid can leak from a container if the container is corroded.
- b) A place where dangerous gas or liquid can be released or leak out due to incorrect operation of equipment or an abnormal reaction of equipment after exposure to high temperature and high pressure.

- c) A place where a dangerous atmosphere is generated due to failure of mandatory ventilation equipment and stagnation of explosive gas.
- d) A place which is indoors around or next to the class-1 environment and rarely has explosive gas with dangerous concentration.

Prohibition of Disassembly and Modification

Warning

Disassembling the pilot valve and barrier can deteriorate the explosion-proof performance, and it may lead to an accident.

Therefore, please do not disassemble or modify the pilot valve and barrier.

Intrinsically Safe Explosion-proof Circuit Wiring

Warning

Wiring of intrinsically safe explosion-proof circuits should not be routed with the other circuits. Also, it should not have electrostatic induction or electromagnetic induction.

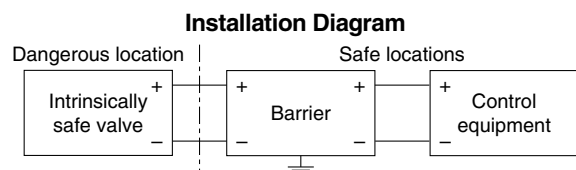

- The solenoid valve has polarity. Confirm the correct polarity by observing the color of the lead wires. Applying a voltage of the wrong polarity may result in damage to the barrier.
- Confirm that the solenoid input voltage at the lead wires is 10.8 VDC (min).
- Use the valve in combination with a barrier which has a "Type Approval Certificate for Ex-Equipment" and satisfies the values shown below in order to configure an intrinsically safe circuit.
 $U_i = 28\text{ V}$ $I_i = 225\text{ mA}$ (resistively limited)
 $P_i = 1\text{ W}$ $C_i = 1.1\text{ nF}$ $L_i = 6.5\text{ }\mu\text{H}$
- Do not repeatedly bend or pull on the lead wire.

Select a barrier that satisfies the following parameters in order to configure an intrinsically safe system.

Equipment		Barrier
U_i	\geq	U_o (or V_{oc})
I_i	\geq	I_o (or I_{sc})
P_i	\geq	P_o
$C_i + C_{\text{cable}}^{*1}$	\leq	C_o (or C_a)
$L_i + L_{\text{cable}}^{*1}$	\leq	L_o (or L_a)

*1 C cable, L cable: The capacitance and inductance of the cable between the equipment and the barrier
If the capacitance and inductance of the cable are unknown, substitute with the following values.
C cable = 110 pF/m, L cable = 1 $\mu\text{H}/\text{m}$
If the barrier P_o is unknown:
 $P_o = (U_o \times I_o)/4$ or $P = (V_{oc} \times I_{sc})/4$



Series 51-SY5000/7000/9000

Specific Product Precautions 6

Be sure to read this before handling the products. For safety instructions and 3/4/5-port solenoid valve precautions, refer to the “Handling Precautions for SMC Products” and the “Operation Manual” on the SMC website: <https://www.smcworld.com>

Reference

Explosion-proof Structure Symbol (Ex ia IIC T5)

Symbols Specified by Technical Standard

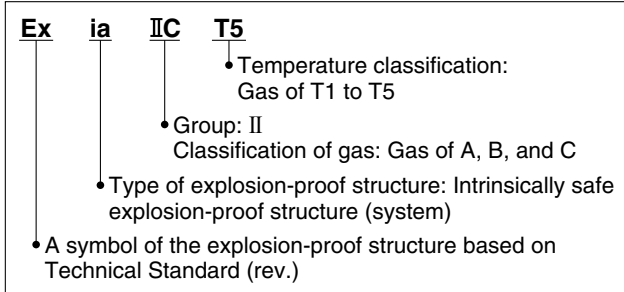

- (1) Groups of explosion-proof equipment
Explosion-proof equipment is classified into two groups depending on the place where electric equipment is used.
Group I: Electric equipment which is used in a dangerous environment within a tunnel or mine
Group II: Electric equipment which is used in a dangerous environment within a factory or office.
SMC valve belongs to Group II.
- (2) Classification of gas
Classification of gas corresponds to the explosion class of gas specified in the conventional standard, and there are three classes, A, B, and C, depending on the characteristics of explosive gas. The classification of gas specifies the dangerous degree as C>B>A. SMC valve is applicable to the gases classified into A, B, and C.
- (3) Temperature class
Temperature class corresponds to the ignition degree of gas specified in the conventional standard, and there are six classes, T1 to T6. T1 is the least dangerous gas which has the highest ignition temperature, and T6 is the most dangerous gas which has the lowest ignition temperature. SMC valve is applicable to T1 to T5 temperature classes.

Record of changes

- Edition B**
- * Deleted the system "C" and "E" from How to Order on page 1, 14, 28, 34.
 - * Deleted the 51-SYE100-C from Zener Diode Barrier Dimensions on page 41.
 - * Deleted the 51-SYE100-E from Insulating Barrier Dimensions on page 42.

NQ



Safety Instructions

Be sure to read "Handling Precautions for SMC Products" (M-E03-3) before using.