

Magnet Buffer

New

RoHS

Stable buffer reaction force during stroke
 Adsorbs workpieces with different heights
 Reduces the impact applied to a workpiece

The buffer reaction force is stable regardless of the stroke position.

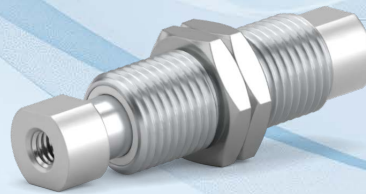
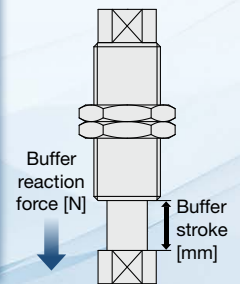
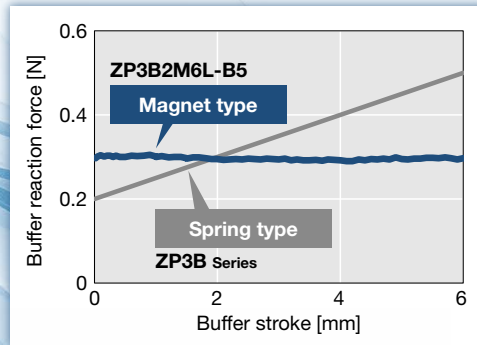

Applicable cup size: $\phi 1.5$ to $\phi 32$
 Connection thread: M3, M5

Low particle generation

No particle generation due to the friction of a spring (spring-less structure)

Non-rotating

Reduces rotation by 4-pole magnets (non-rotating mechanism principle [p. 2](#))

Copper and zinc-free*1

Compatible with the secondary battery manufacturing process*1

*1 Excluding ZP3B3M(3,6,16)H-B5

Variations

Buffer size	Buffer stroke [mm]	Buffer reaction force [N]		Applicable cup size	
		L	H	Min.	Max.
M8 x 0.75	3	0.15 ± 0.05	0.3 ± 0.1	ø1.5	ø5
	6				
M10 x 1.0	3	0.3 ± 0.1	0.5 ± 0.1		
	6				
M12 x 1.0	3	0.5 ± 0.1	1.0 ± 0.1		ø32
	6				
	16				

ZP3B□M Series



CAT.ES100-176A

Magnet Buffer

ZP3B□M Series

RoHS

How to Order

ZP3B **1** M **3** L - **B3**

①

②

③

④

● Magnet type, Non-rotating

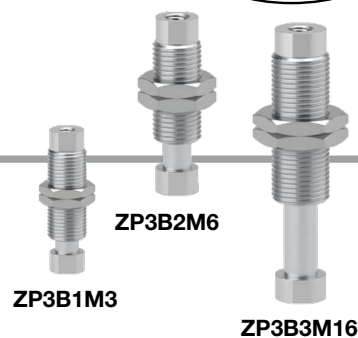

① Buffer size

Symbol	Connection thread
1	M8 x 0.75
2	M10 x 1.0
3	M12 x 1.0

② Stroke

Symbol	Stroke	Applicable body size		
		M8 x 0.75	M10 x 1.0	M12 x 1.0
3	3 mm	●	●	●
6	6 mm	●	●	●
16	16 mm	—	—	●

③ Buffer reaction force

Symbol	Applicable body size					
	M8 x 0.75		M10 x 1.0		M12 x 1.0	
	Buffer reaction force [N]					
	0.15 ±0.05	0.3 ±0.1	0.3 ±0.1	0.5 ±0.1	0.5 ±0.1	1.0 ±1.0
L	●	—	●	—	●	—
H	—	●	—	●	—	●

④ Adapter/Vacuum inlet thread size

Symbol	Type	Thread size	④ Adapter/Vacuum inlet thread size		
			Applicable buffer size		
			M8 x 0.75	M10 x 1.0	M12 x 1.0
B3	Female thread	M3 x 0.5	●	—	—
B5		M5 x 0.8	—	●	●
Applicable cup size		Min.	ø1.5	ø1.5	ø1.5
		Max.	ø5	ø20	ø32

Specifications

At an ambient temperature of 23°C

Model	ZP3B1M				ZP3B2M				ZP3B3M					
Buffer type	Magnet													
With or without non-rotating	With*1													
With or without bushing	With													
Ambient and fluid temperatures [°C]	5 to 50													
Stroke [mm]	3	6	3	6	3	6	3	6	3	6	16	3	6	16
Buffer reaction force [N]*2	0.15 ±0.05		0.3 ±0.1		0.3 ±0.1		0.5 ±0.1		0.5 ±0.1			1.0 ±0.1		
Accuracy of buffer reaction force [%]*2	Within ±15 F.S.													
Max. holding torque [N·m]*3	0.25 or more		0.5 or more		0.5 or more		0.8 or more		0.8 or more		1.3 or more	1.4 or more		3.4 or more
Connection thread	M8 x 0.75				M10 x 1.0				M12 x 1.0					
Nut tightening torque [N·m]	1.5 to 2.0				2.5 to 3.5				4.5 to 5.5					
Cup adapter/Vacuum inlet	M3 x 0.5				M5 x 0.8									

*1 By the magnetic holding

*2 For the details about the product terminology, refer to the operation manual of this product.

*3 When the force is applied over the maximum holding torque, the rod rotates 180° from its original position.

The holding torque is the force that allows the rod to return to its original position when an external force has been applied and removed.

Construction Principle

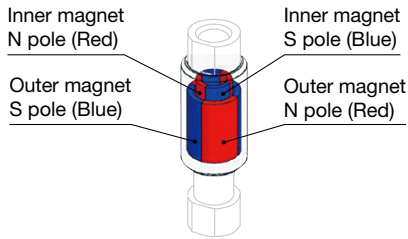

Construction Principle

<Buffer principle>

1. The N pole (red) and S pole (blue) balance by attracting each other in the stroke direction.
2. After applying an external force in the direction that pushes into the rod, it returns to its original position when the force is removed.

<Non-rotating mechanism principle>

1. The rod balances at the position that the N pole (red) and S pole (blue) are facing.
2. After applying an external, clockwise force that does not exceed the maximum allowable torque into the rod, the rod returns to its original position when the force is removed.
3. After applying an external, counterclockwise force that does not exceed the maximum allowable torque into the rod, the rod returns to its original position when the force is removed.
4. After applying an external force that exceeds the maximum allowable torque into the rod clockwise, the rod rotates 180° from its original position when the force is removed. And then, it balances at the position that the N pole (red) and S pole (blue) are facing.

Construction

Basic type

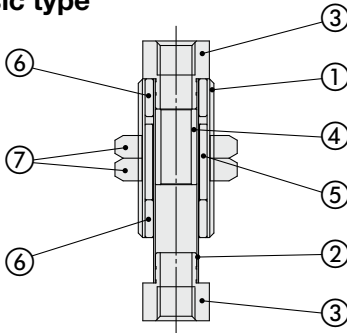

No.	Description	Material (Surface treatment)	Note
1	Buffer body R	Stainless steel	
2	Piston tube	Stainless steel	
3	Cup adapter	Aluminum alloy (Clear anodized)	
4	Inner magnet	Neodymium magnet	
5	Outer magnet	Neodymium magnet	
6	Bushing	POM	
7	Nut	Stainless steel	

Dimensions/Models

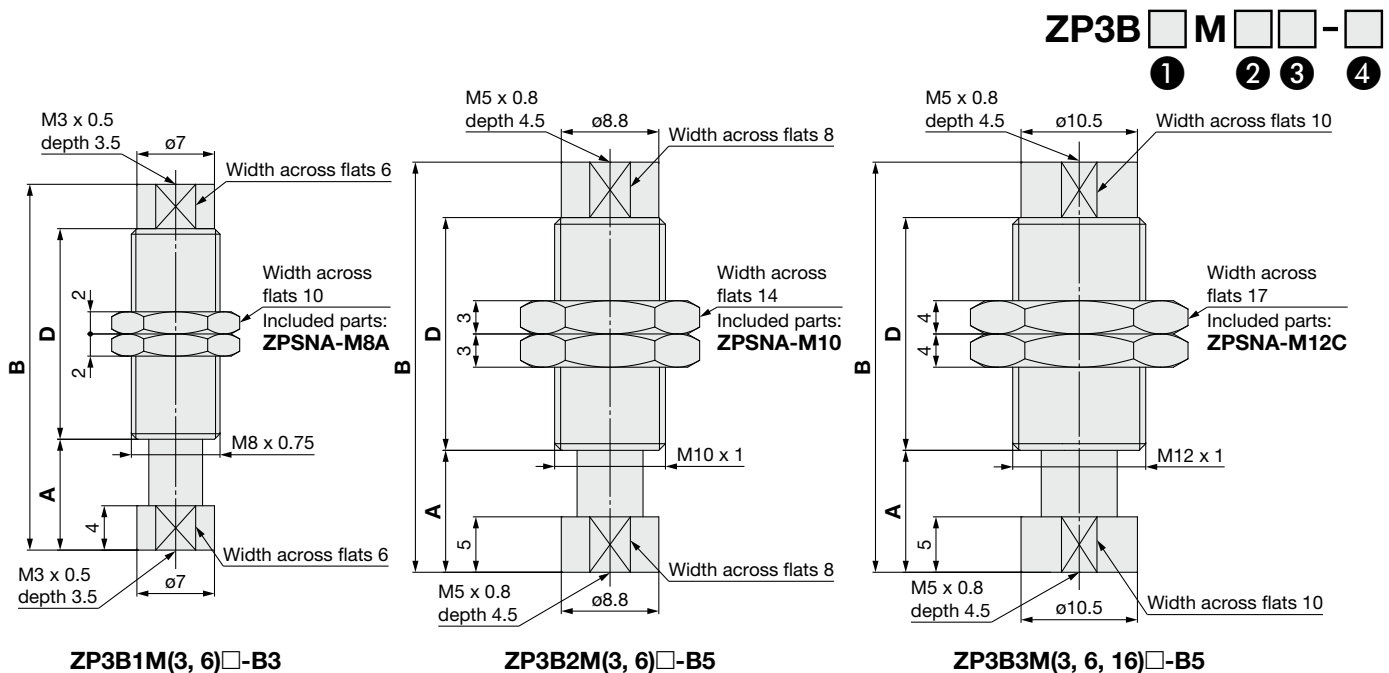



	Model					A	B	D	Minimum hole size	Weight [g]
	1 Buffer size	2 Specifications	3 Buffer stroke	4 Buffer reaction force	5 Adapter mounting thread size/ Vacuum inlet					
ZP3B	1	M	3	L H	B3	7	30	19	ø2	5.6
			6			10	33			5.7
			2		3	B5	8	34	ø4	11.3
					6		11	37		11.4
	3		3	L	B5	8	34	21	ø4.2	18.1
				H						19.3
			6	L		11	37	ø2.8	18.2	
				H					19.4	
			16	L		21	57	31	ø4.2	23.8
				H						ø2.8

Safety Instructions

These safety instructions are intended to prevent hazardous situations and/or equipment damage. These instructions indicate the level of potential hazard with the labels of “**Caution**,” “**Warning**” or “**Danger**.” They are all important notes for safety and must be followed in addition to International Standards (ISO/IEC)*1), and other safety regulations.

 **Danger :** **Danger** indicates a hazard with a high level of risk which, if not avoided, will result in death or serious injury.

 **Warning:** **Warning** indicates a hazard with a medium level of risk which, if not avoided, could result in death or serious injury.

 **Caution:** **Caution** indicates a hazard with a low level of risk which, if not avoided, could result in minor or moderate injury.

*1) ISO 4414: Pneumatic fluid power - General rules and safety requirements for systems and their components
ISO 4413: Hydraulic fluid power - General rules and safety requirements for systems and their components
IEC 60204-1: Safety of machinery - Electrical equipment of machines - Part 1: General requirements
ISO 10218-1: Robots and robotic devices - Safety requirements for industrial robots - Part 1: Robots etc.

Warning

1. The compatibility of the product is the responsibility of the person who designs the equipment or decides its specifications.

Since the product specified here is used under various operating conditions, its compatibility with specific equipment must be decided by the person who designs the equipment or decides its specifications based on necessary analysis and test results. The expected performance and safety assurance of the equipment will be the responsibility of the person who has determined its compatibility with the product. This person should also continuously review all specifications of the product referring to its latest catalog information, with a view to giving due consideration to any possibility of equipment failure when configuring the equipment.

2. Only personnel with appropriate training should operate machinery and equipment.

The product specified here may become unsafe if handled incorrectly. The assembly, operation and maintenance of machines or equipment including our products must be performed by an operator who is appropriately trained and experienced.

3. Do not service or attempt to remove product and machinery/equipment until safety is confirmed.

1. The inspection and maintenance of machinery/equipment should only be performed after measures to prevent falling or runaway of the driven objects have been confirmed.
2. When the product is to be removed, confirm that the safety measures as mentioned above are implemented and the power from any appropriate source is cut, and read and understand the specific product precautions of all relevant products carefully.
3. Before machinery/equipment is restarted, take measures to prevent unexpected operation and malfunction.

4. SMC products cannot be used beyond their specifications. They are not developed, designed, and manufactured to be used under the following conditions or environments. Use under such conditions or environments is not allowed.

1. Conditions and environments outside of the given specifications, or use outdoors or in a place exposed to direct sunlight.
2. Use for nuclear power, railways, aviation, space equipment, ships, vehicles, military application, equipment affecting human life, body, and property, combustion equipment, entertainment equipment, emergency shut-off circuits, press clutches, brake circuits, safety equipment, etc., and use for applications that do not conform to standard specifications such as catalogs and operation manuals.
3. Use for interlock circuits, except for use with double interlock such as installing a mechanical protection function in case of failure. Please periodically inspect the product to confirm that the product is operating properly.

Caution

SMC develops, designs, and manufactures products to be used for automatic control equipment, and provides them for peaceful use in manufacturing industries.

Use in non-manufacturing industries is not allowed.

Products SMC manufactures and sells cannot be used for the purpose of transactions or certification specified in the Measurement Act of each country. The new Measurement Act prohibits use of any unit other than SI units in Japan.

Limited warranty and Disclaimer/ Compliance Requirements

The product used is subject to the following “Limited warranty and Disclaimer” and “Compliance Requirements”.

Read and accept them before using the product.

Limited warranty and Disclaimer

1. The warranty period of the product is 1 year in service or 1.5 years after the product is delivered, whichever is first.*2)
Also, the product may have specified durability, running distance or replacement parts. Please consult your nearest sales branch.
2. For any failure or damage reported within the warranty period which is clearly our responsibility, a replacement product or necessary parts will be provided.
This limited warranty applies only to our product independently, and not to any other damage incurred due to the failure of the product.
3. Prior to using SMC products, please read and understand the warranty terms and disclaimers noted in the specified catalog for the particular products.

*2) **Suction cups (Vacuum pads) are excluded from this 1 year warranty.**

A suction cup (vacuum pad) is a consumable part, so it is warranted for a year after it is delivered.

Also, even within the warranty period, the wear of a product due to the use of the suction cup (vacuum pad) or failure due to the deterioration of rubber material are not allowed by the limited warranty.

Compliance Requirements

1. The use of SMC products with production equipment for the manufacture of weapons of mass destruction (WMD) or any other weapon is strictly prohibited.
2. The exports of SMC products or technology from one country to another are governed by the relevant security laws and regulations of the countries involved in the transaction. Prior to the shipment of a SMC product to another country, assure that all local rules governing that export are known and followed.

Safety Instructions

Be sure to read the “Handling Precautions for SMC Products” (M-E03-3) and “Operation Manual” before use.