

Vacuum Gripper System

(Foam Type)



Suitable for the palletizing and depalletizing of corrugated cardboard, etc.

Ejector unit

Combines all functions required for adsorption

Ejector

Supply valve/Release valve

Silencer

Pressure switch

IO-Link compatible*1

*1 Only for sizes 300 x 180 and 200 x 120

Can be used immediately by simply connecting 1 electrical cable and air piping

Compatible with the collaborative robots of 4 companies

UNIVERSAL ROBOTS
OMRON/TECHMAN ROBOT
FANUC
YASKAWA Electric

75 mm*1
to the robot
mounting
flange top
surface



400 mm

240 mm

New

81.5 mm*1
to the robot
mounting
flange top
surface



300 mm

180 mm

New

81.5 mm*1
to the robot
mounting
flange top
surface



200 mm

120 mm

*1 For foam thicknesses of 20 mm
Depending on the compatible robot

Weight

1.3 kg (200 x 120)

1.8 kg (300 x 180)

3.9 kg (400 x 240)

CO₂ emissions (Air consumption)

Max. **15%** reduction
(SMC comparison)

Ejector with new design

227 L/min (ANR) ← 270 L/min (ANR)

Compared to ZL6H (Supply pressure: 0.6 MPa)

Lifting force

440 N (200 x 120) (At -63 kPa)

880 N (300 x 180) (At -63 kPa)

2144 N (400 x 240) (At -75 kPa)

ZGS Series



CAT.ES100-169B

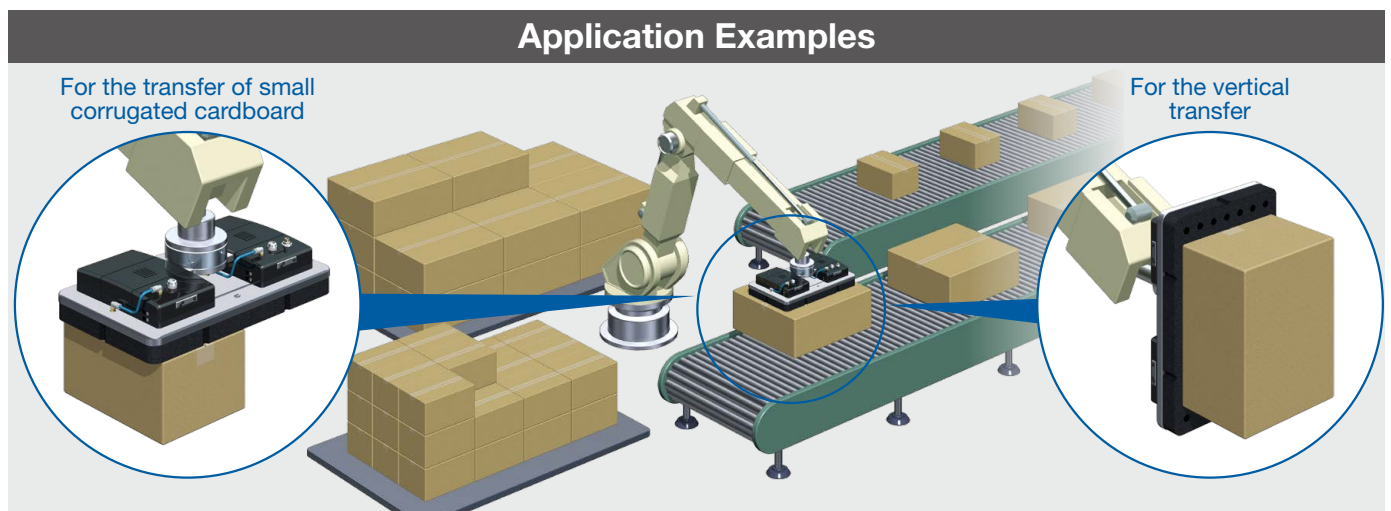
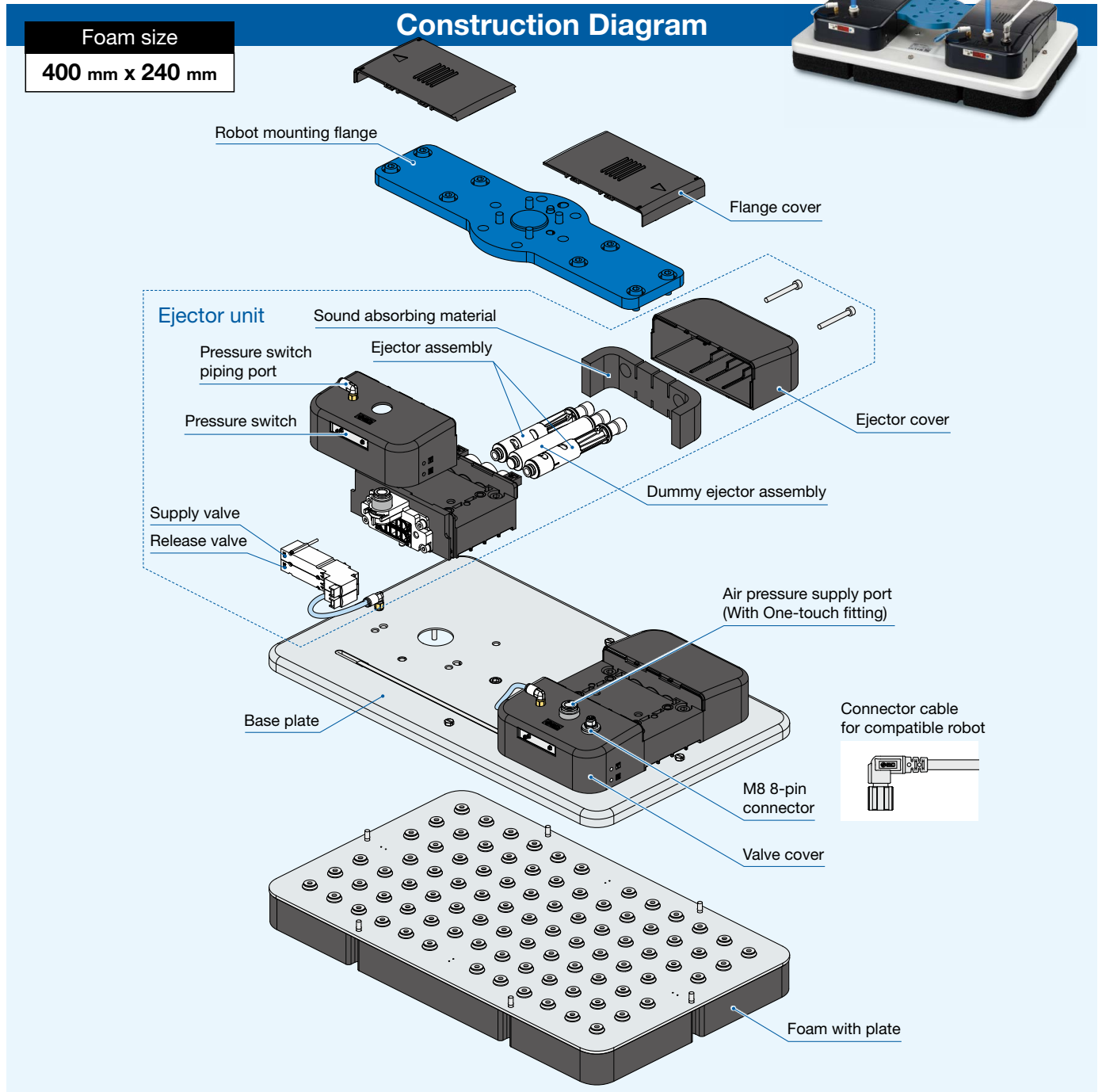

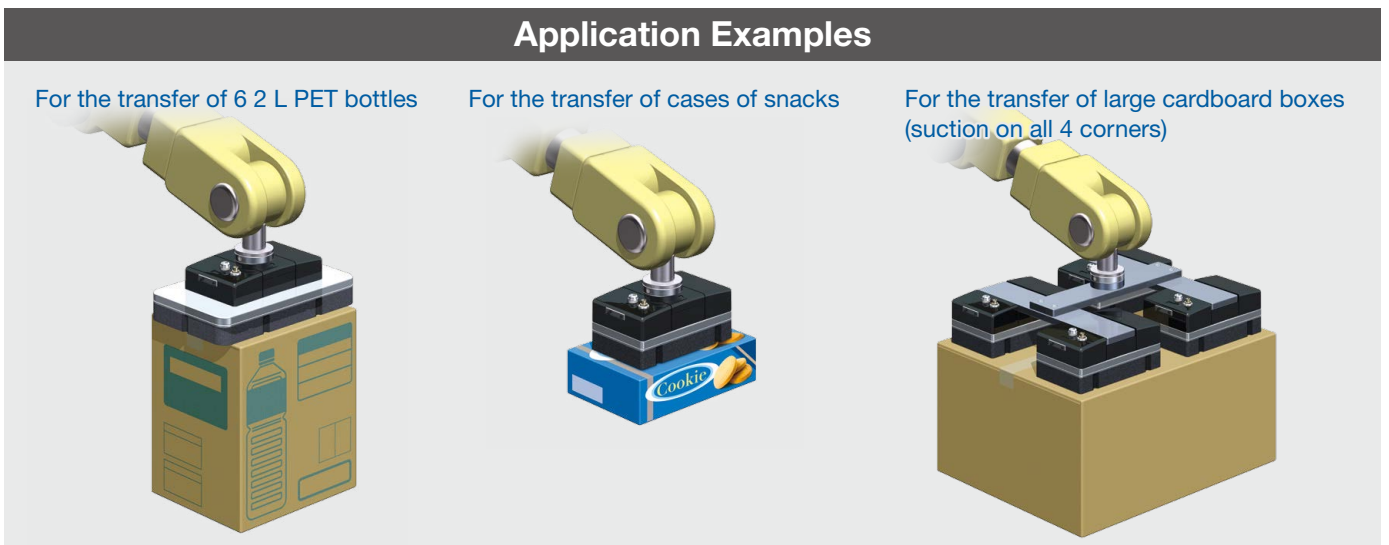
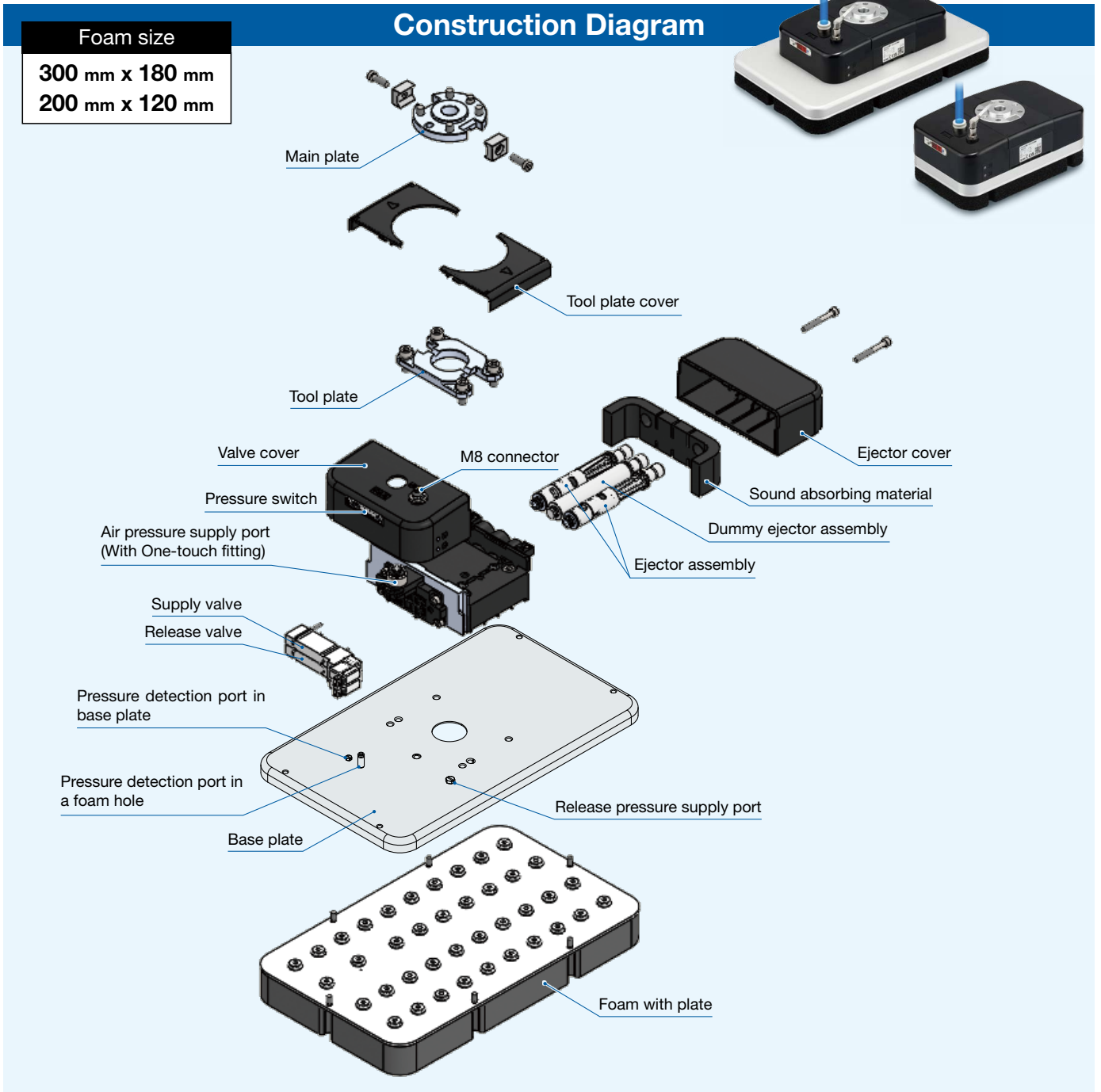

Ejector Unit

Newly designed ejector for the Vacuum Gripper System

- Number of ejector assemblies (2 pcs, 4 pcs, 6 pcs) can be selected.

For size 400 x 240

Number of ejector assemblies	Suction flow rate [L/min (ANR)]
2	322
4	646
6	1022

- * For details, refer to the ejector flow rate characteristics
- * The values are for reference only.

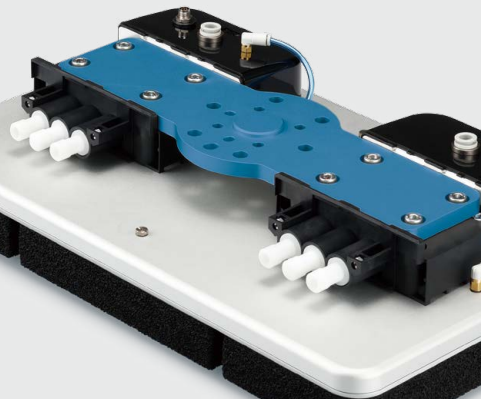

- Energy-saving (Air consumption reduced by up to 15% compared to ZL6H)

Flow rate characteristics improvement in the practical range below -50 kPa

Flow Rate Characteristics Comparison

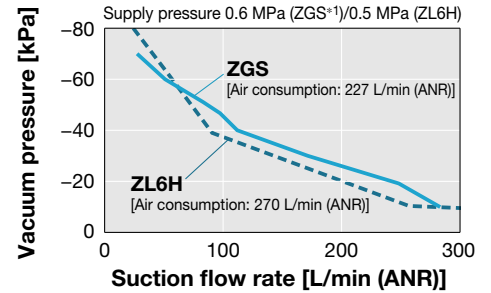

*1 The flow rate characteristics for the single ejector unit when the ejector assembly is 4 pcs.

LED indicator for supply and release valve operation.



Easy tool changing due to common tool changer*1

*1 Only for sizes 300 x 180 and 200 x 120

• Easy tool changing (Manual changer)

- Tools can be secured by simply tightening the 2 clamber bolts.
- Reduces work-hours
- * Note that the lifting force may be limited when the tool plate and main plate are used. See the Suction Plate Selection Guide for details.

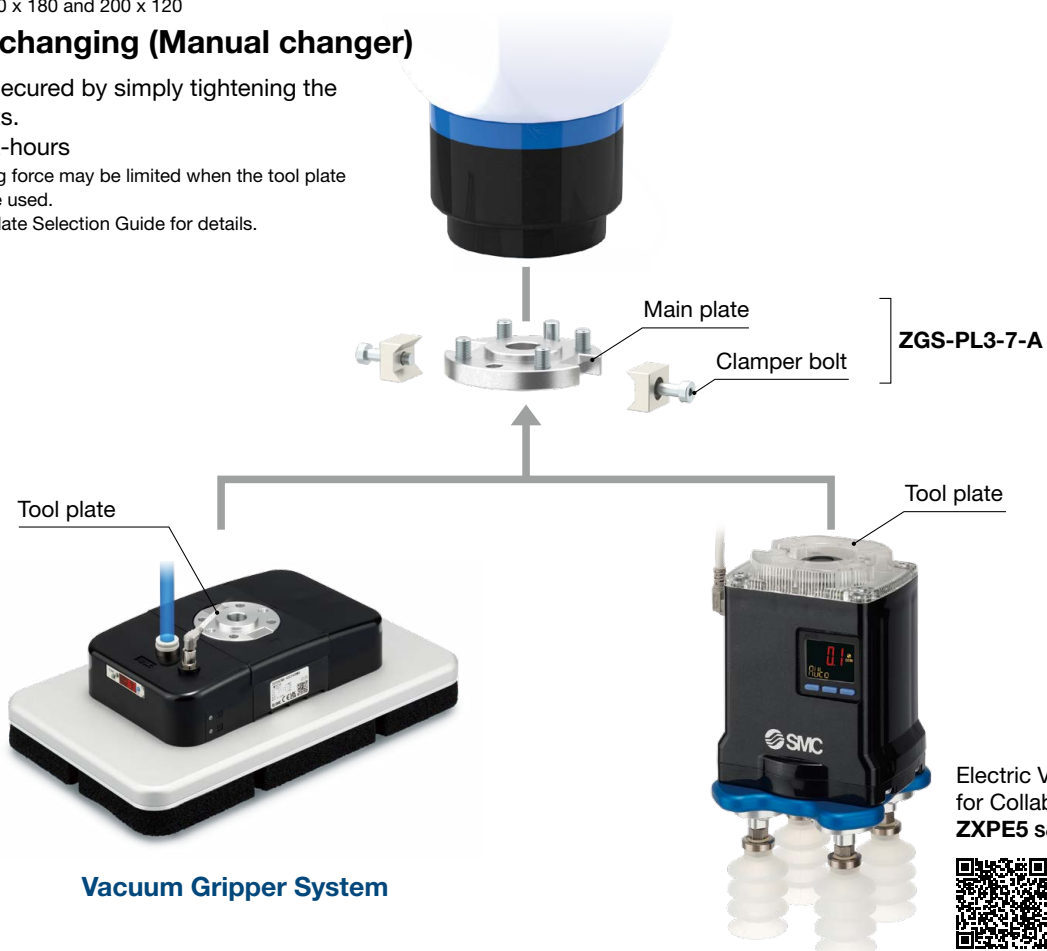

Ejector Unit

Built-in pressure switch. Pressure in a foam can be detected.

With $\varnothing 4$ One-touch fittings and polyurethane tubing

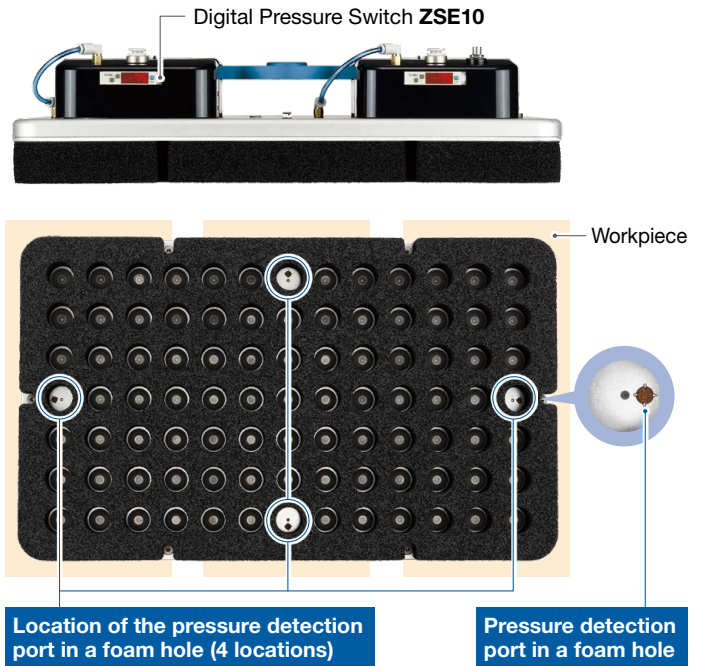
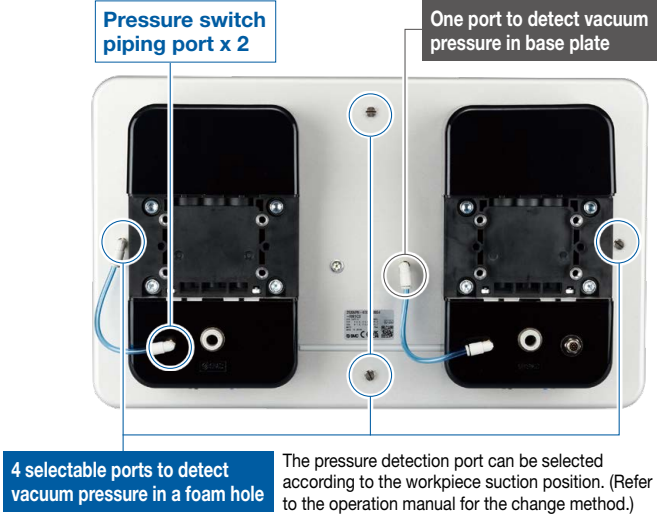

Selectable pressure detection ports (300 mm x 180 mm, 200 x 120 mm)

- Select from base plate pressure detection or foam hole pressure detection via the part number.
- Having the pressure detection ports within the ejector unit allows for a sleek appearance without any visible piping.
- This also eliminates the risk of piping getting pulled out.
- The pressure detection ports can be changed by the customer later.

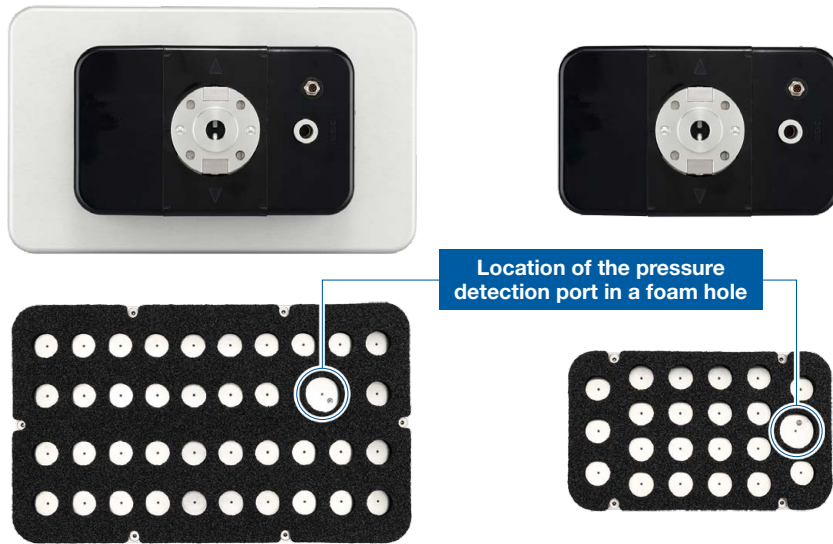

Usage example of the pressure detection port in a foam hole

Pressure detection port in a foam hole

Example Pressure in a foam hole: 0 kPa
Detects the workpiece drop

Pressure detection port in base plate

Example Pressure in base plate: -50 kPa

This port can be used to check that the workpiece is gripped. Note, however, that if a workpiece is dropped, the vacuum saving valves will be closed, which will increase the vacuum pressure in the base plate and may prevent detection of the drop of the workpiece.

Suction Plate

■ 2 suction plates can be selected according to the workpiece size.

Vacuum saving valve type



Significantly suppresses vacuum pressure drop when used with multiple workpieces or when workpiece is smaller than the suction plate.
 → Various-sized workpieces can be adsorbed by 1 unit.

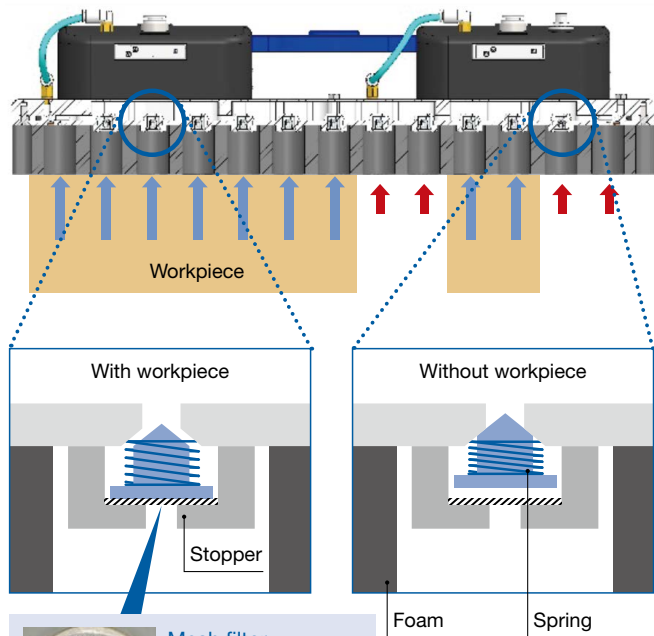



Mesh filter
 Measures against dust
 Mesh size $\phi 0.2$ mm
 (Guide)

No restrictions on orientation during the adsorption
 Vertical transfer is possible.

Fixed orifice type



Suitable for use with workpiece that is approximately same size as suction plate
 Suppresses vacuum pressure drop

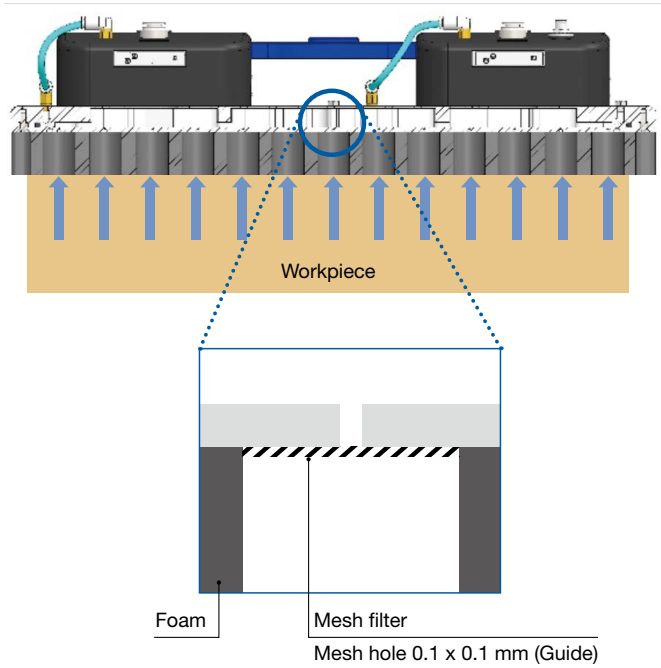

* The above illustration is only for reference and differs from the actual construction.

■ 2 foam thicknesses can be selected according to the workpiece surface shape.

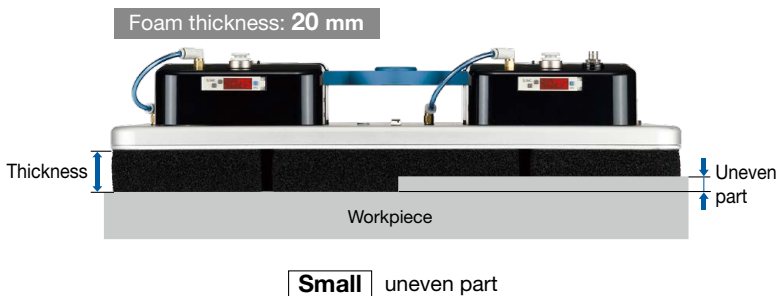

Improved foam durability due to stopper

By mounting a stopper, the amount of foam compression can be regulated. This reduces the collapse of cells within the foam during suction.

Number of cycles: Improved by more than 2 times

(Comparison under SMC's test conditions, without a stopper)

Number of Cycles and Ultimate Vacuum Pressure

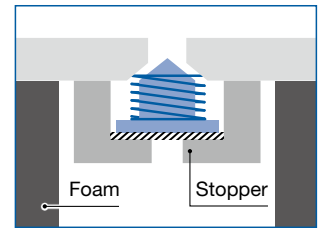
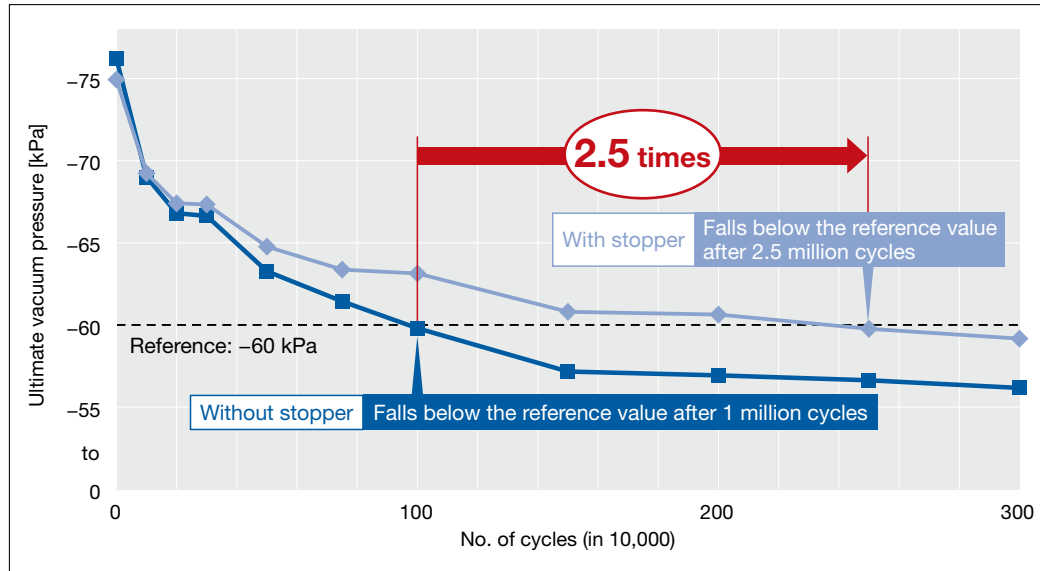

Vacuum saving valve type Image

* Based on SMC's test conditions at 70% of compression.

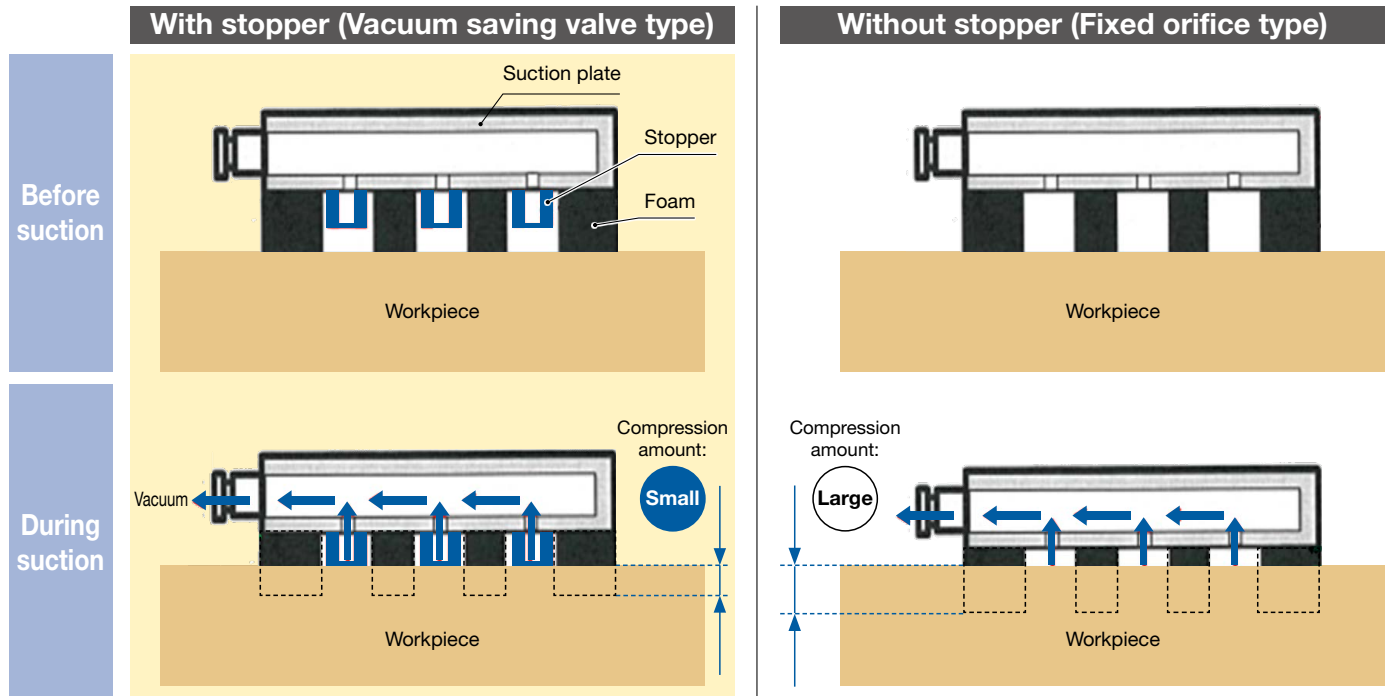

Suction Plate

Suction Plate Selection Guide

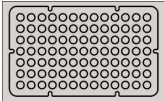
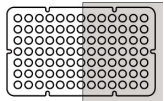
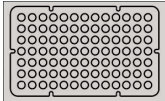
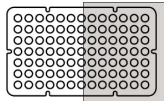
Foam size		400 mm x 240 mm		Vacuum saving valve type		Fixed orifice type	
Number of ejector assemblies	Standard supply pressure* ³ [MPa]	Suction area [%]* ⁴	100%	Approx. 50%	100%	Approx. 50%	
		Number of suction holes [pcs.]	91/91	42/91	91/91	42/91	
		Workpiece: Acrylic plate					
2 pcs.	0.58	Vacuum pressure [kPa]* ¹	-75.0	-3.6	-75.0	-11.1	
		Lifting force [N]* ²	2144	—* ⁵	2144	146	
		Lifting force considering safety factor [N]	Horizontal lifting (Safety factor: 4)	536	—	536	36
			Vertical lifting (Safety factor: 8)	268	—	268	18
4 pcs.	0.6	Vacuum pressure [kPa]* ¹	-75.0	-57.0	-75.0	-27.6	
		Lifting force [N]* ²	2144	752	2144	364	
		Lifting force considering safety factor [N]	Horizontal lifting (Safety factor: 4)	536	188	536	91
			Vertical lifting (Safety factor: 8)	268	94	268	45
6 pcs.	0.6	Vacuum pressure [kPa]* ¹	-75.0	-61.2	-75.0	-33.6	
		Lifting force [N]* ²	2144	808	2144	443	
		Lifting force considering safety factor [N]	Horizontal lifting (Safety factor: 4)	536	201	536	110
			Vertical lifting (Safety factor: 8)	268	100	268	55

- *1 The vacuum pressure is the actual measured value when non-leakage workpiece (acrylic plate) is suctioned at the standard supply pressure. It is not guaranteed values.
- *2 The lifting force is an actual value measured by SMC at the above vacuum pressure and is not a guaranteed value. It is necessary to judge the suitability for the workpiece with actual condition of use.
- *3 This is the pressure immediately before the air pressure supply (P) port of the vacuum gripper system during suction. It is affected by air supply capacity, pipe size, air consumption of other equipment operating simultaneously, etc. During vacuum generation, the pressure immediately before the air pressure supply (P) port of the vacuum gripper system may fall below the standard supply pressure.
- *4 Vacuum saving valve may not be activated when suction area is small.
- *5 This indicates that vacuum saving valves don't work.

Suction Plate Selection Guide

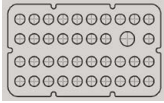
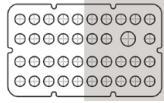
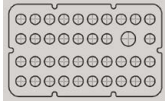
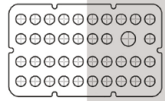
Foam size		300 mm x 180 mm		Vacuum saving valve type		Fixed orifice type	
Number of ejector assemblies	Standard supply pressure* ³ [MPa]	Suction area [%]* ⁴	100%	Approx. 50%	100%	Approx. 50%	
		Number of suction holes [pcs.]	39/39	19/39	39/39	19/39	
		Workpiece: Acrylic plate					
1 pc.	0.45	Vacuum pressure [kPa]* ¹	-63.0	-5.0	-63.0	-15.4	
		Lifting force [N]* ²	880 (400)	—* ⁵	880 (400)	107	
		Lifting force considering safety factor [N]	Horizontal lifting (Safety factor: 4)	220 (100)	—	220 (100)	26
			Vertical lifting (Safety factor: 8)	110 (50)	—	110 (50)	13
2 pcs.	0.45	Vacuum pressure [kPa]* ¹	-62.0	-51.0	-62.0	-27.7	
		Lifting force [N]* ²	880 (400)	350	880 (400)	186	
		Lifting force considering safety factor [N]	Horizontal lifting (Safety factor: 4)	220 (100)	87	220 (100)	46
			Vertical lifting (Safety factor: 8)	110 (50)	43	110 (50)	23
3 pcs.	0.45	Vacuum pressure [kPa]* ¹	-60.0	-52.0	-60.0	-36.8	
		Lifting force [N]* ²	880 (400)	357	880 (400)	237	
		Lifting force considering safety factor [N]	Horizontal lifting (Safety factor: 4)	220 (100)	89	220 (100)	59
			Vertical lifting (Safety factor: 8)	110 (50)	44	110 (50)	29

- *1 The vacuum pressure is the actual measured value when non-leakage workpiece (acrylic plate) is suctioned at the standard supply pressure. It is not guaranteed values.
- *2 The lifting force is an actual value measured by SMC at the above vacuum pressure and is not a guaranteed value. (Values in parentheses indicate values when the tool plate and main plate are used.) It is necessary to judge the suitability for the workpiece with actual condition of use.
- *3 This is the pressure immediately before the air pressure supply (P) port of the vacuum gripper system during suction. It is affected by air supply capacity, pipe size, air consumption of other equipment operating simultaneously, etc. During vacuum generation, the pressure immediately before the air pressure supply (P) port of the vacuum gripper system may fall below the standard supply pressure.
- *4 Vacuum saving valve may not be activated when suction area is small.
- *5 This indicates that vacuum saving valves don't work.

Suction Plate

Suction Plate Selection Guide

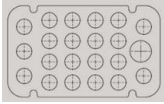
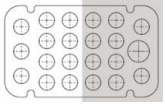
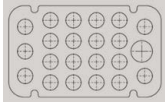
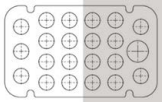
Foam size		200 mm x 120 mm		Vacuum saving valve type		Fixed orifice type	
Number of ejector assemblies	Standard supply pressure*3 [MPa]	Suction area [%]*4	100%	Approx. 50%	100%	Approx. 50%	
		Number of suction holes [pcs.]	22/22	11/22	22/22	11/22	
		Workpiece: Acrylic plate					
1 pc.	0.45	Vacuum pressure [kPa]*1	-63.0	-51.0	-63.0	-26.8	
		Lifting force [N]*2	440 (400)	190	440 (400)	80	
		Lifting force considering safety factor [N]	Horizontal lifting (Safety factor: 4)	110 (100)	47	110 (100)	20
			Vertical lifting (Safety factor: 8)	55 (50)	23	55 (50)	10
2 pcs.	0.45	Vacuum pressure [kPa]*1	-62.0	-57.0	-62.0	-42.8	
		Lifting force [N]*2	440 (400)	210	440 (400)	140	
		Lifting force considering safety factor [N]	Horizontal lifting (Safety factor: 4)	110 (100)	52	110 (100)	35
			Vertical lifting (Safety factor: 8)	55 (50)	26	55 (50)	17

*1 The vacuum pressure is the actual measured value when non-leakage workpiece (acrylic plate) is suctioned at the standard supply pressure. It is not guaranteed values.

*2 The lifting force is an actual value measured by SMC at the above vacuum pressure and is not a guaranteed value. (Values in parentheses indicate values when the tool plate and main plate are used.)

It is necessary to judge the suitability for the workpiece with actual condition of use.

*3 This is the pressure immediately before the air pressure supply (P) port of the vacuum gripper system during suction. It is affected by air supply capacity, pipe size, air consumption of other equipment operating simultaneously, etc. During vacuum generation, the pressure immediately before the air pressure supply (P) port of the vacuum gripper system may fall below the standard supply pressure.

*4 Vacuum saving valve may not be activated when suction area is small.

Variations

Foam specifications		Suction plate		Number of ejector assemblies (Max. suction flow rate)			
Thickness				Workpiece size	Vacuum saving valve type	Air leakage from a workpiece	400 x 240
Level of workpiece front/back surface unevenness	20 mm or 30 mm	Small ↑ Large	or				
Even ↑ ↓ Uneven				2 pcs. x 2 = 4 pcs. (646 L/min (ANR))	2 pcs. (352 L/min (ANR))	2 pcs. (352 L/min (ANR))	
				3 pcs. x 2 = 6 pcs. (1022 L/min (ANR))	3 pcs. (515 L/min (ANR))	—	

CONTENTS

Vacuum Gripper System (Foam Type) ZGS Series



• Foam Size: 400 mm x 240 mm

How to Order	p. 11
Specifications	p. 12
Ejector Flow Rate Characteristics	p. 12
Ejector Exhaust Characteristics	p. 13
Dimensions	p. 14

• Foam Size: 300 mm x 180 mm, 200 mm x 120 mm

How to Order	p. 19
Specifications	p. 20
Ejector Flow Rate Characteristics	p. 20
Ejector Exhaust Characteristics	p. 21
Dimensions	p. 22

Connector Cable for Compatible Robot	p. 33
Robot Mounting Flange	p. 33
Specific Product Precautions	p. 37

Foam Size: 400 mm x 240 mm

Foam Size: 300 mm x 180 mm
Foam Size: 200 mm x 120 mm

Connector Cable
Robot Mounting Flange

Vacuum Gripper System (Foam Type)

ZGS Series

Foam Size: 400 mm x 240 mm



How to Order

ZGS **NP** **K** - **400240** **B** **S** **4** - **R** **M** **1** **C8**

①
②
③
④
⑤
⑥
⑦
⑧
⑨
⑩

① Compatible robot

Symbol		Robot manufacturer	Supported model	Switch output		Valve polarity
Identification symbol	Output type			PNP	NPN	
N	P	—	General purpose	PNP	—COM	
	N			NPN	+COM	
011	P	UNIVERSAL ROBOTS	UR10e	PNP	—COM	
			UR16e			
012			UR20			
021	N	OMRON/TECHMAN ROBOT	TM12(S)	NPN	+COM	
			TM14(S)			
			TM16			
			TM20			
			TM25S			
043	P	YASKAWA Electric	MOTOMAN-HC10(S)DTP	PNP	—COM	
			MOTOMAN-HC20(S)DTP			
	N		MOTOMAN-HC10(S)DTP	NPN	+COM	
			MOTOMAN-HC20(S)DTP			
051	P	FANUC	CRX-10iA(L)	PNP	—COM	
			CRX-20iA			
			CRX-25iA			

② Supply valve/Release valve

Symbol	Supply valve	Release valve
B	N.O.	N.C.
K	N.C.	N.C.
Nil	None	None

③ Foam size

400240	400 mm x 240 mm
---------------	-----------------

④ Foam

A	Thickness 20 mm (Number of holes: 91)
B	Thickness 30 mm (Number of holes: 91)

⑤ Suction plate

S	Vacuum saving valve type
M	Fixed orifice type

* The vacuum saving valve type has a stopper, and the fixed orifice type has no stopper.

⑥ Number of ejector assemblies

2	2 pcs.
4	4 pcs.
6	6 pcs.

* Total number of 2 ejector units
Refer to page 12 for the flow rate characteristics.

⑦ Connector cable for compatible robot (Refer to page 33.)

Nil	With cable (For compatible models)
R	With cable (Discrete wire)
N	Without cable

* When "Identification symbol: N" is selected in ① Compatible robot, "Nil: With cable (For compatible models)" cannot be selected.

For compatible robot

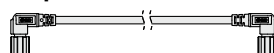

Discrete wire

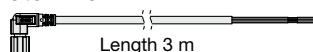

⑧ Pressure switch unit specifications

Symbol	Switch unit
C	With unit switching function
M	SI unit only

* Under the New Measurement Act, switches with the unit switching function are not permitted for use in Japan.
(Only symbol: M can be selected in Japan.)

⑨ Robot mounting flange (Refer to page 33.)

Nil	Without robot mounting flange
1	Basic type (Conforming to ISO 9409-1-50-4-M6)
2	Basic type (Conforming to ISO 9409-1-50-4-M6) + Offset flange

* Symbol "2" can only be selected for compatible robot 021N (OMRON/TECHMAN ROBOT). (For other compatible robots, "2" cannot be selected.) In addition, the basic type, symbol "1," cannot be selected for compatible robot 021N (OMRON/TECHMAN ROBOT). (However, "Nil: Without robot mounting flange" can be selected.)

⑩ Air pressure supply (P) port

C8	Metric	ø8 One-touch fitting
C10		ø10 One-touch fitting
N9	Inch	ø5/16" One-touch fitting
N11		ø3/8" One-touch fitting

Vacuum Gripper System Specifications



Number of ejector assemblies	2	4	6
Fluid	Air		
Operating pressure range [MPa]	0.3 to 0.7		
Operating temperature range [°C]	5 to 50		
Standard supply pressure [MPa]	0.58	0.6	0.6
Max. vacuum pressure [kPa]	-75		
Air consumption [L/min (ANR)]	228	454	661
Weight [kg]*1	3.9		
Power supply voltage [V]	24 VDC ±10%		
Power consumption [W]	2.7		
Supply valve/Release valve	Equivalent to JSY3140-5MOZ-□		
Vacuum pressure switch	Equivalent to ZSE10-00-□		

*1 For ZGSNPK-400240BS4-RM1C8

Refer to the JSY3000 series **Web Catalog** for the specifications of the supply valve and release valve.
Refer to the ZSE10 series **Web Catalog** for vacuum pressure switch specifications.



JSY3000



ZSE10

Ejector Flow Rate Characteristics (Reference value)*1

(Supply pressure as shown in the table below)

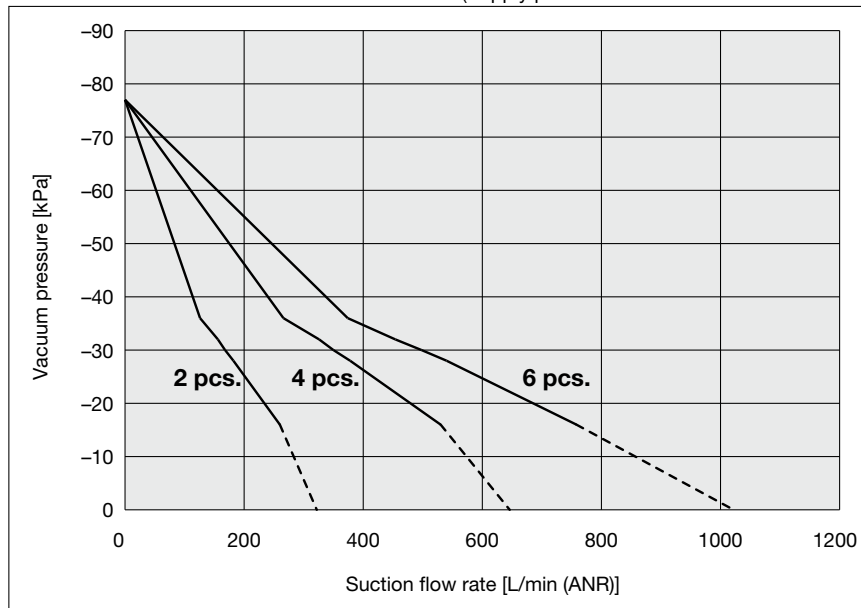

*1 Suction flow rates are measured under SMC test conditions and are not guaranteed. The dotted lines and values in parentheses in the table below are estimates based on measured values.

Suction flow rate for each number of ejector assemblies

Number of ejector assemblies	Supply pressure [MPa]	Suction flow rate [L/min (ANR)] for each vacuum pressure [kPa]							
		0	-10	-20	-30	-40	-50	-60	-70
2 pcs.	0.58	(322)	286	238	168	110	80	46	22
4 pcs.	0.6	(646)	574	490	350	222	172	104	54
6 pcs.	0.6	(1022)	(864)	706	498	338	250	144	66

Exhaust Noise (Reference value)

Exhaust noise [dB(A)]	70
-----------------------	----

* Actual values under SMC's measurement conditions (Not guaranteed values)

Ejector Exhaust Characteristics (Reference value)*1

*1 Measured under SMC test conditions and are not guaranteed

Number of ejector assemblies: 2

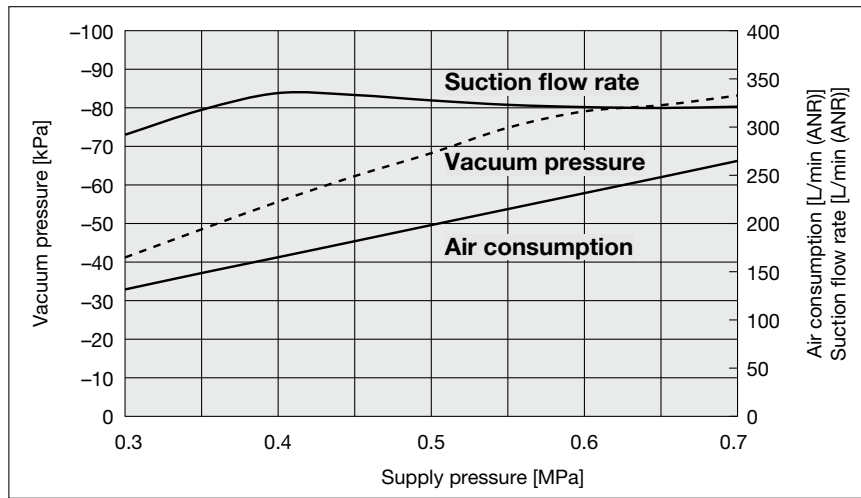

Number of ejector assemblies: 4

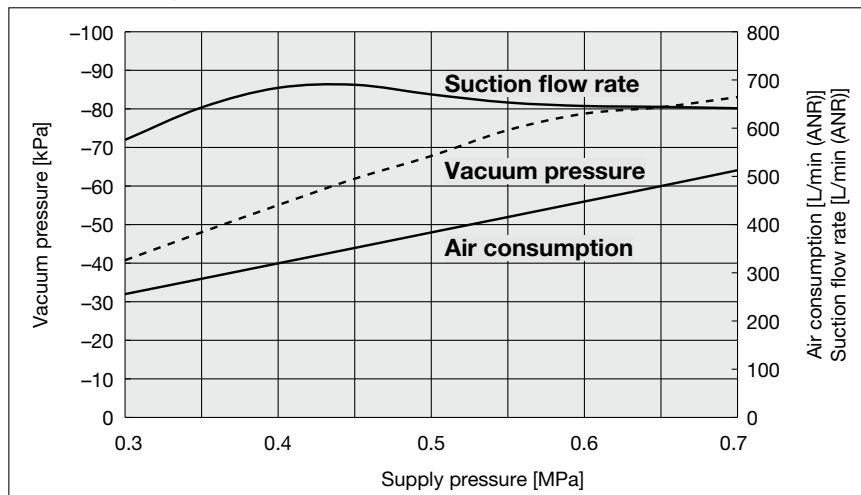

Number of ejector assemblies: 6

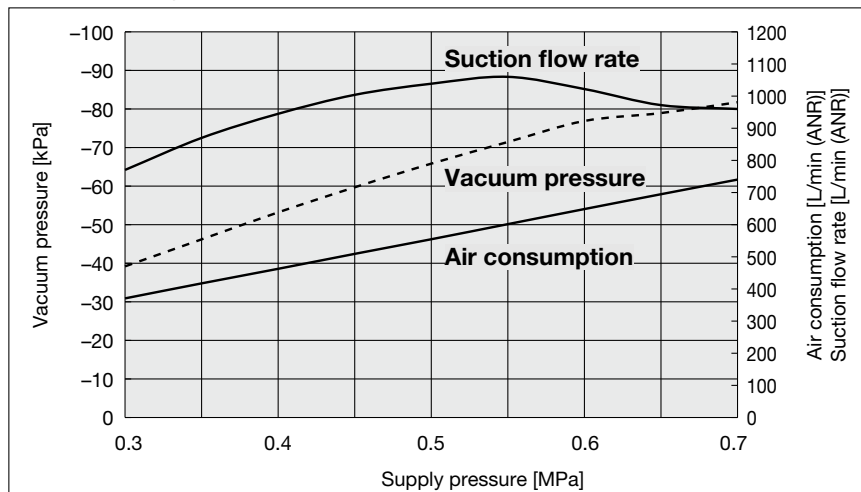

Dimensions

Robot mounting flange: Basic type

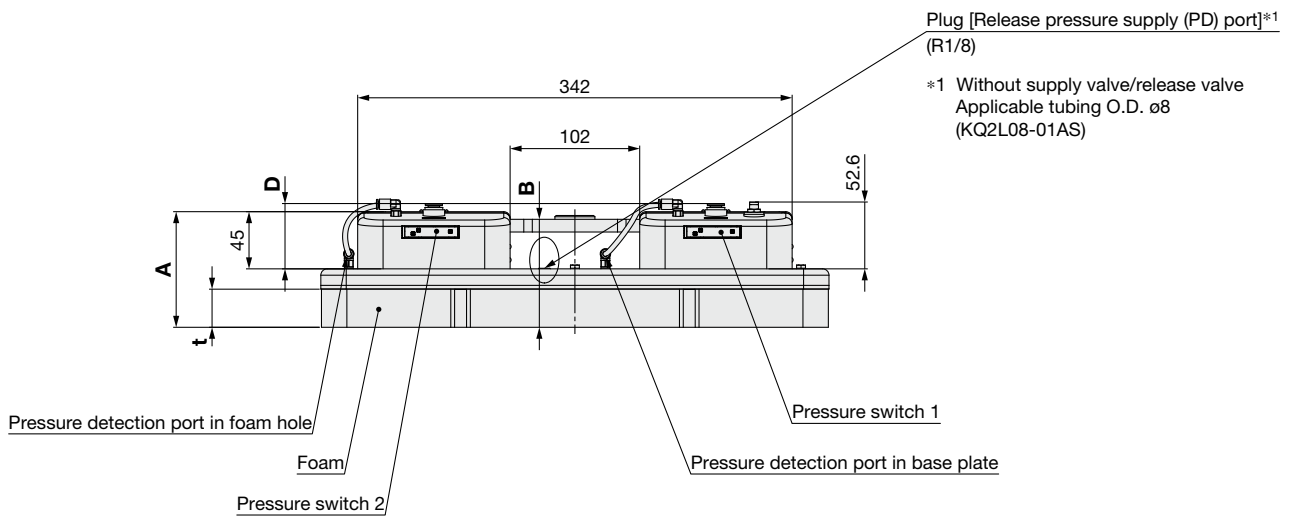
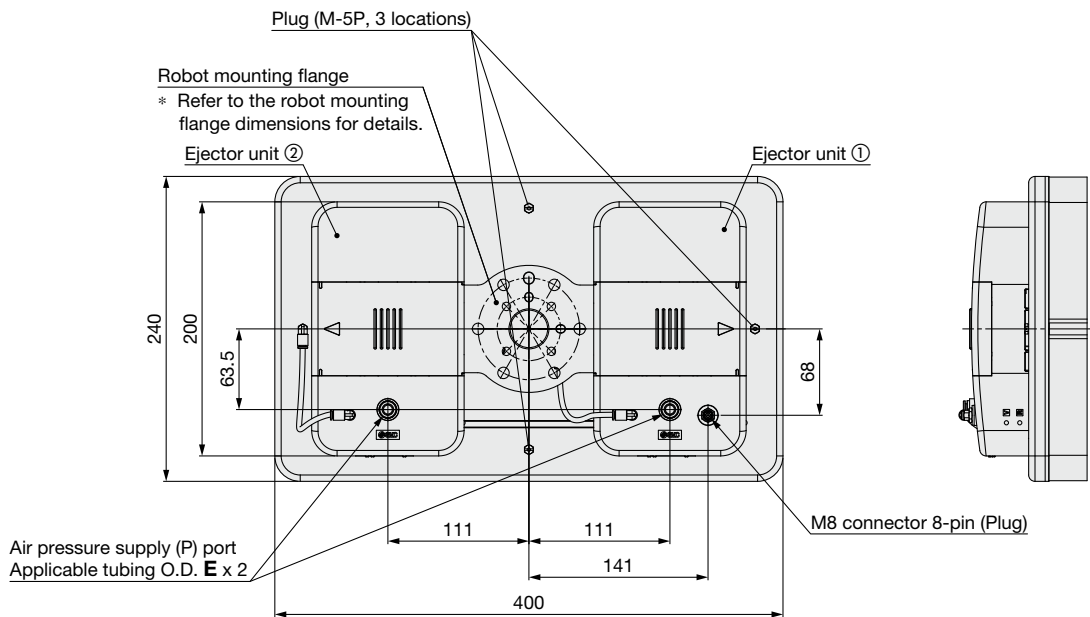

Part no.	t	A	B
ZGS□□-400240A□□□-□□□□	20	81	75
ZGS□□-400240B□□□-□□□□	30	91	85

Part no.	D	E
ZGS□□-400240□□□□-□□□□C8	51.4	ø8
ZGS□□-400240□□□□-□□□□C10	52	ø10
ZGS□□-400240□□□□-□□□□N9	51.4	ø5/16"
ZGS□□-400240□□□□-□□□□N11	51.9	ø3/8"

Foam Size: 400 mm x 240 mm

Foam Size: 300 mm x 180 mm
Foam Size: 200 mm x 120 mm

Connector Cable
Robot Mounting Flange

ZGS Series

Dimensions

Without robot mounting flange

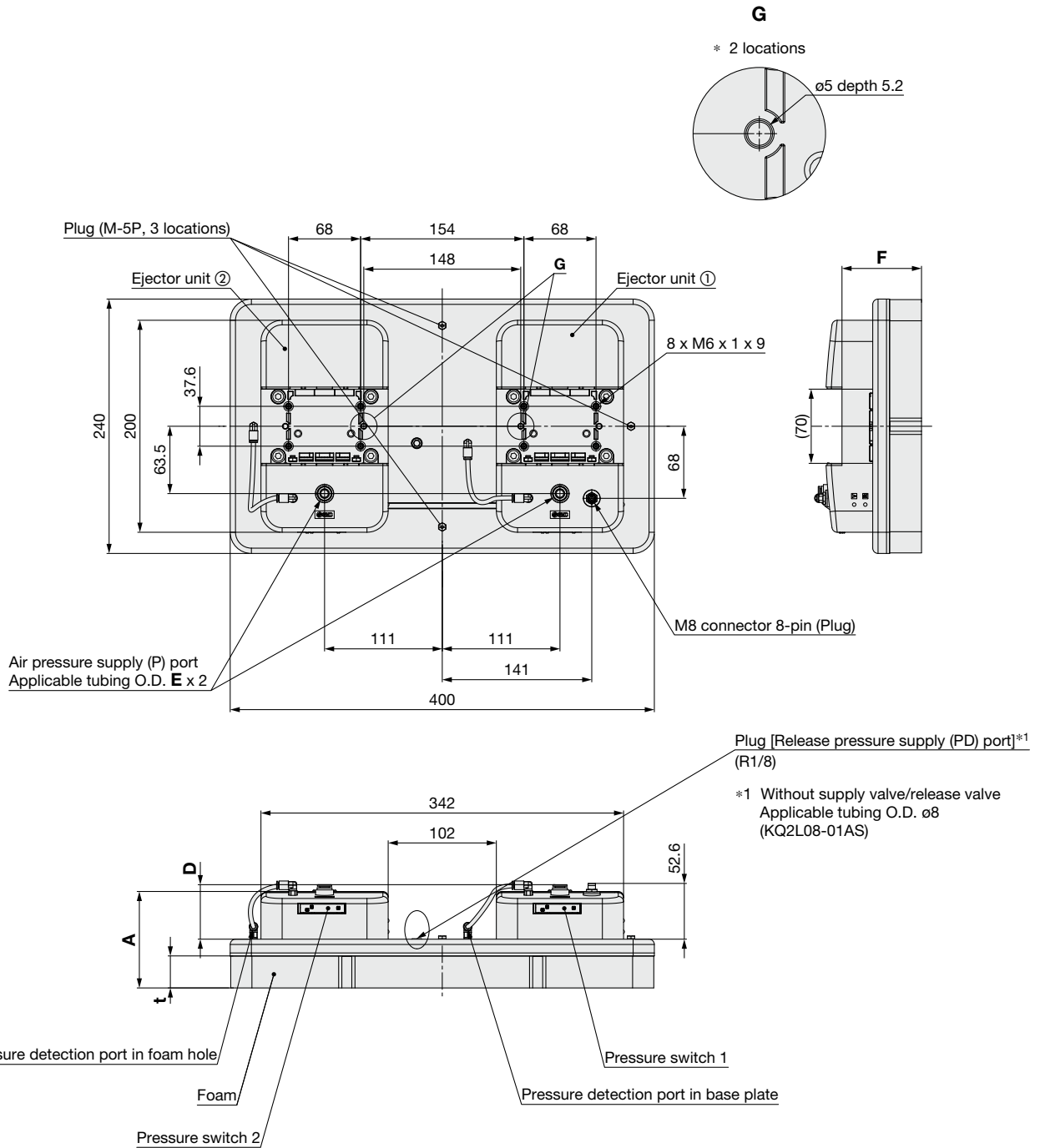

Part no.	t	A	F
ZGS□□-400240□□□-□□□□	20	81	65
ZGS□□-400240B□□□-□□□□	30	91	75

Part no.	D	E
ZGS□□-400240□□□□-□□□□C8	51.4	ø8
ZGS□□-400240□□□□-□□□□C10	52	ø10
ZGS□□-400240□□□□-□□□□N9	51.4	ø5/16"
ZGS□□-400240□□□□-□□□□N11	51.9	ø3/8"

Dimensions

Robot mounting flange: Basic type + Offset flange

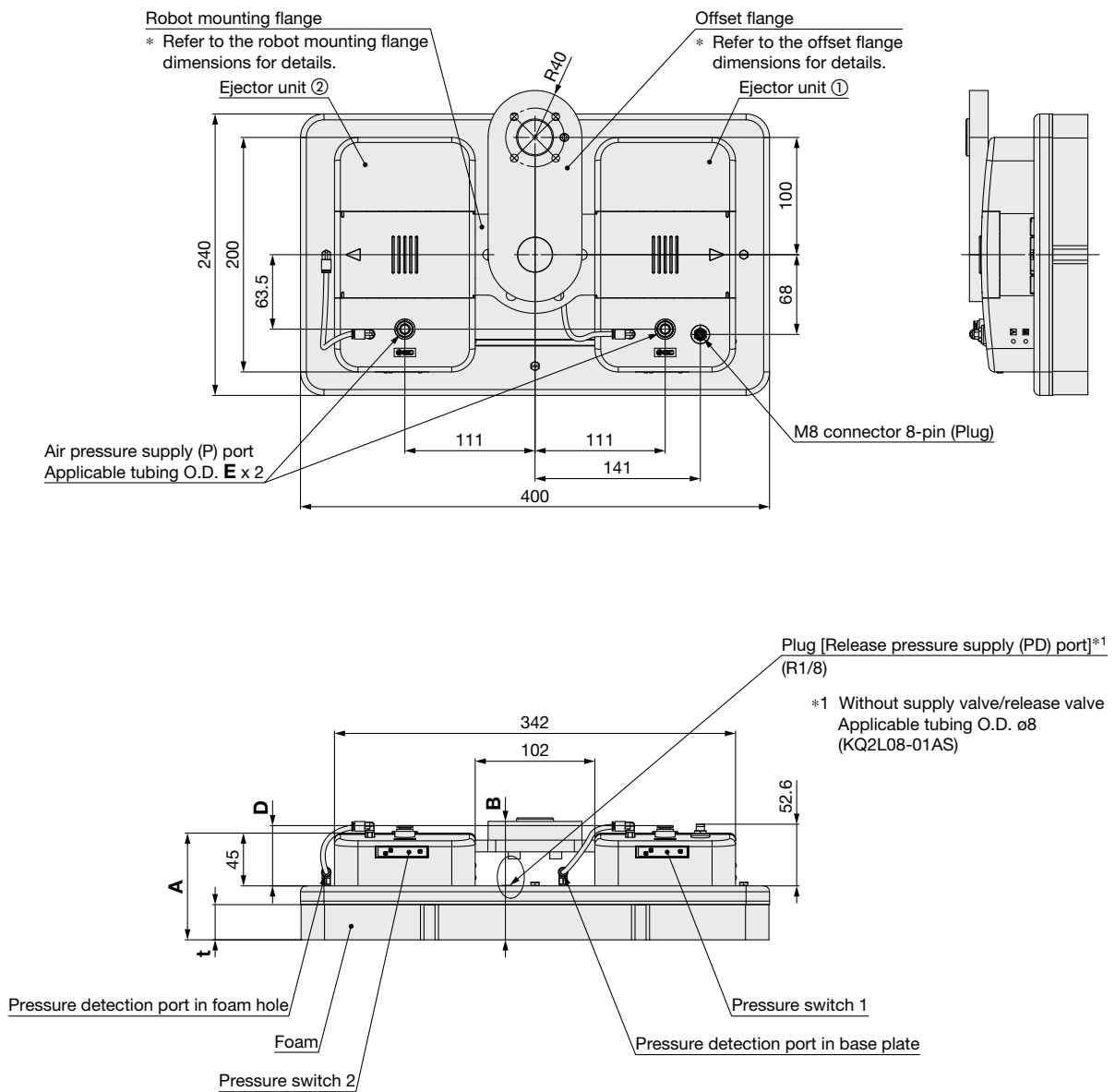

Part no.	t	A	B
ZGS021N□-400240A□□-□□2□	20	81	91
ZGS021N□-400240B□□-□□2□	30	91	101

Part no.	D	E
ZGS021N□-400240□□□-□□□C8	51.4	$\phi 8$
ZGS021N□-400240□□□-□□□C10	52	$\phi 10$
ZGS021N□-400240□□□-□□□N9	51.4	$\phi 5/16"$
ZGS021N□-400240□□□-□□□N11	51.9	$\phi 3/8"$

Foam Size: 400 mm x 240 mm

Foam Size: 300 mm x 180 mm
Foam Size: 200 mm x 120 mm

Connector Cable
Robot Mounting Flange

Dimensions

Robot mounting flange

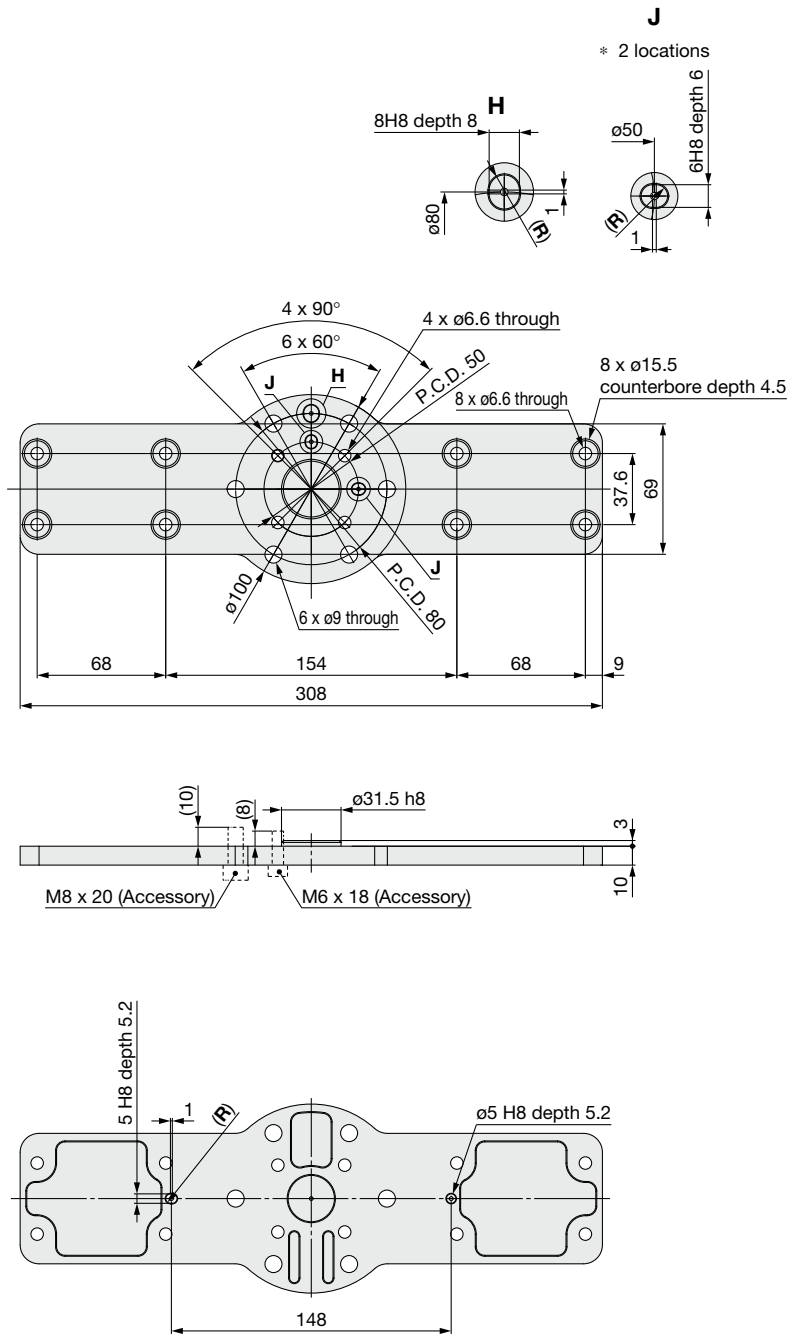

Dimensions

Offset flange

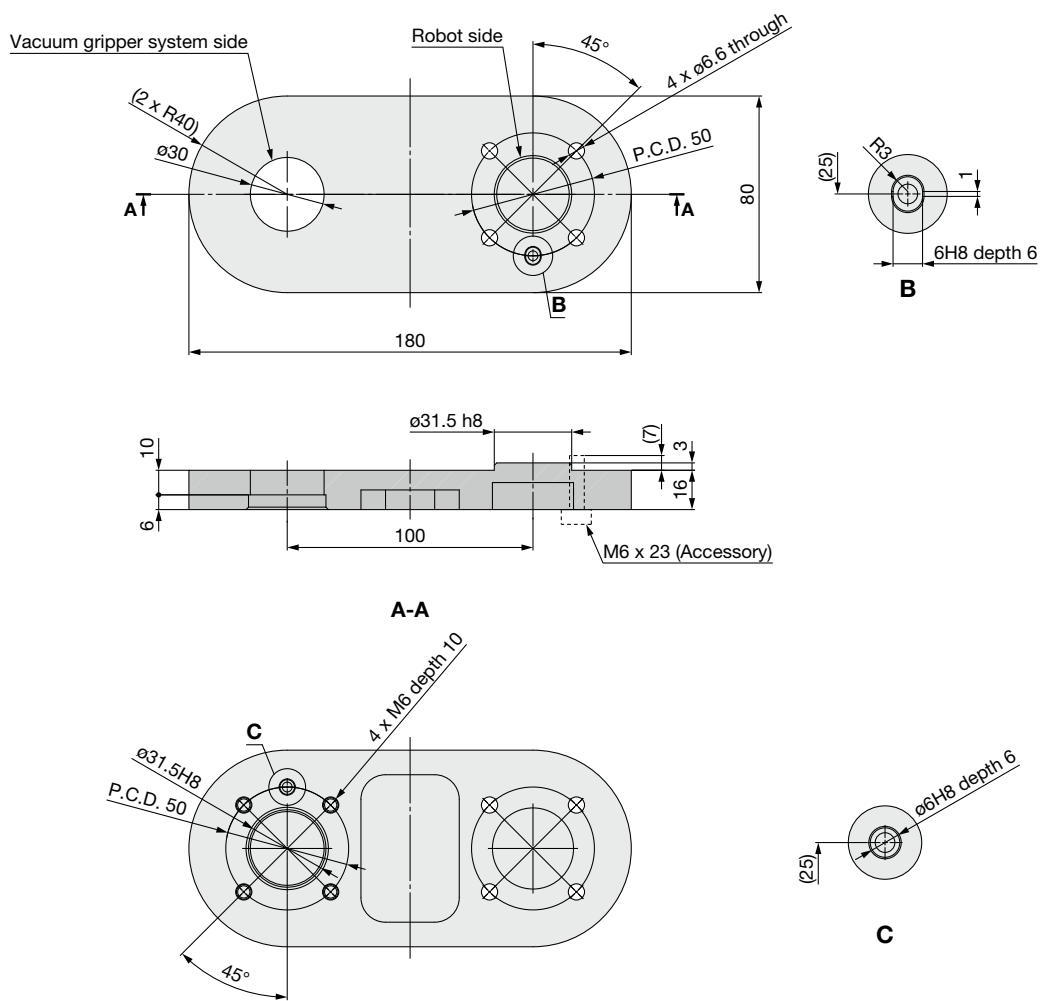

Foam Size: 400 mm x 240 mm

Foam Size: 300 mm x 180 mm
Foam Size: 200 mm x 120 mm

Connector Cable
Robot Mounting Flange

Vacuum Gripper System (Foam Type)

ZGS Series

Foam Size: 300 mm x 180 mm, 200 mm x 120 mm

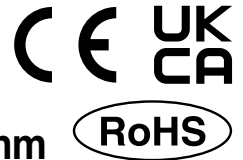

How to Order

ZGS **NP** **K** - **300180** **B** **S** **2** - **R** **Y** **1** **C8**

①
②
③
④
⑤
⑥
⑦
⑧
⑨
⑩

① Compatible robot

Symbol		Robot manufacturer	Supported model	Switch output	Valve polarity
Identification symbol	Output type				
N	P	-	General purpose	PNP	-COM
	N				
	H				
011	P	UNIVERSAL ROBOTS	UR3e	PNP	-COM
012			UR5e		
			UR10e		
			UR16e		
021	N	OMRON/TECHMAN ROBOT	UR20	NPN	+COM
			TM5(S)		
			TM7S		
			TM12(S)		
			TM14(S)		
			TM16		
			TM20		
TM25S					
043	P	YASKAWA Electric	MOTOMAN-HC10(S)DTP	PNP	-COM
			MOTOMAN-HC20(S)DTP		
	N		MOTOMAN-HC10(S)DTP	NPN	+COM
			MOTOMAN-HC20(S)DTP		
051	P	FANUC	CRX-5iA	PNP	-COM
			CRX-10iA(L)		
			CRX-20iA		
			CRX-25iA		

② Supply valve/Release valve

Symbol	Supply valve	Release valve
B	N.O.	N.C.
K	N.C.	N.C.
Nil	None	None

* When "H" is selected for the compatible robot output type, "Nil" cannot be selected.

⑦ Connector cable for compatible robot

Symbol	Connector cable for compatible robot
Nil	With cable (For compatible models)
R	With cable (Discrete wire)
N	Without cable

* When "Symbol: N (P, N)" is selected in ① Compatible robot, "Nil: With cable (For compatible models)" cannot be selected. In addition, when "NH" is selected for the ① compatible robot, only "N" (Without cable) can be selected. (Refer to page 33 for details on the connector cable for compatible robots.)

⑧ Pressure switch unit specifications

Symbol	Switch unit	Pressure detection location
W	With unit switching function	Pressure in base plate
X		Pressure in a foam hole
Y	SI unit only	Pressure in base plate
Z		Pressure in a foam hole

* Under the New Measurement Act, switches with the unit switching function are not permitted for use in Japan. (For use within Japan, symbols "Y" or "Z" can be selected.)

⑨ Robot mounting flange (Refer to pages 34 and 36.)

Symbol	Robot mounting flange*1
Nil	Without robot mounting flange
1	Tool plate + Main plate
2	Offset flange*2
3	Tool plate only*3

- *1 The following two options are available for mounting the gripper on the robot:
 - Offset flange
 - Tool plate + Main plate.
 Depending on the robot supported, an additional flange is provided. See the Robot Mounting Flange options for details.
 Note that the lifting force may be limited when the tool plate and main plate are used. See the Suction Plate Selection Guide for details.
- *2 For Compatible robot: 021 (OMRON TECHMAN ROBOT), two options are available:
 - (no flange required) and 2.
- *3 3: Tool plate only is available for users who already have the main plate (ZGS-PL3-7-A).

⑩ Air pressure supply (P) port

Symbol	Air pressure supply (P) port		
C8	Metric	Straight	ø8 One-touch fitting
C10			ø10 One-touch fitting
N9	Inch	Straight	ø5/16" One-touch fitting
N11			ø3/8" One-touch fitting

③ Foam size/④ Foam/⑤ Suction plate/⑥ Number of ejector assemblies

Symbol	③ Foam size	④ Foam		⑤ Suction plate	⑥ Number of ejector assemblies			
		Thickness (Number of holes)						
300180AS1	300180: 300 mm x 180 mm	A: 20 mm (39 holes)	S: Vacuum saving valve type	M: Fixed orifice type	1: 1 pc.			
300180AS2					2: 2 pcs.			
300180AS3					3: 3 pcs.			
300180AM1					1: 1 pc.			
300180AM2					2: 2 pcs.			
300180AM3					3: 3 pcs.			
300180BS1		B: 30 mm (39 holes)	S: Vacuum saving valve type	M: Fixed orifice type	1: 1 pc.			
300180BS2					2: 2 pcs.			
300180BS3					3: 3 pcs.			
300180BM1					1: 1 pc.			
300180BM2					2: 2 pcs.			
300180BM3					3: 3 pcs.			
200120AS1		200120: 200 mm x 120 mm	A: 20 mm (22 holes)	S: Vacuum saving valve type	M: Fixed orifice type	1: 1 pc.		
200120AS2						2: 2 pcs.		
200120AM1						1: 1 pc.		
200120AM2	2: 2 pcs.							
200120BS1	B: 30 mm (22 holes)					S: Vacuum saving valve type	M: Fixed orifice type	1: 1 pc.
200120BS2								2: 2 pcs.
200120BM1			1: 1 pc.					
200120BM2			2: 2 pcs.					

* The vacuum saving valve type has a stopper, and the fixed orifice type has no stopper.

Vacuum Gripper System Specifications



Number of ejector assemblies	1	2	3
Fluid	Air		
Operating pressure range [MPa]	0.3 to 0.7		
Operating temperature range [°C]	5 to 50		
Standard supply pressure [MPa]	0.45		
Max. vacuum pressure [kPa]	-63	-62	-60
Air consumption [L/min (ANR)]	92	177	257
Weight [kg]	Size 300 x 180*1	1.8	
	Size 200 x 120*2	1.3	—
Power supply voltage [V]	24 VDC ±10%		
Power consumption [W]	1.4		
Supply valve/Release valve	Equivalent to JSY3140-5MOZ-□		
Vacuum pressure switch	Equivalent to ZSE10-00-□		

*1 For ZGSNPK-300180AM3-RY1C8

*2 For ZGSNPK-200120AM2-RY1C8

Refer to the JSY3000 series **Web Catalog** for the specifications of the supply valve and release valve.
Refer to the ZSE10 series **Web Catalog** for vacuum pressure switch specifications.



JSY3000



ZSE10

Foam Size: 400 mm x 240 mm

Ejector Flow Rate Characteristics (Reference value)*1

(Supply pressure as shown in the table below)

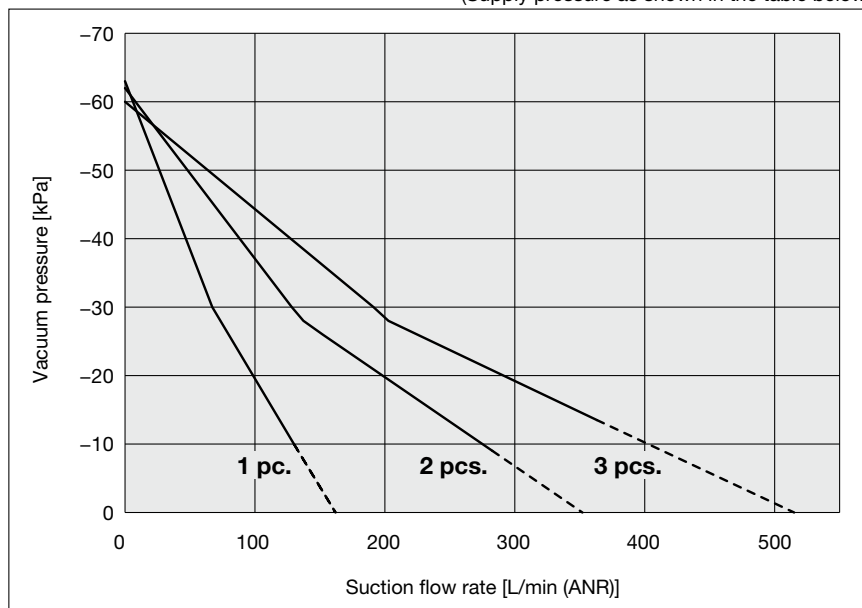

*1 Suction flow rates are measured under SMC test conditions and are not guaranteed. The dotted lines and values in parentheses in the table below are estimates based on measured values.

Foam Size: 300 mm x 180 mm
Foam Size: 200 mm x 120 mm

Connector Cable
Robot Mounting Flange

Suction flow rate for each number of ejector assemblies

Number of ejector assemblies	Supply pressure [MPa]	Suction flow rate [L/min (ANR)] for each vacuum pressure [kPa]					
		0	-10	-20	-30	-40	-50
1 pc.	0.45	(162)	130	99	67	47	26
2 pcs.		(352)	275	198	128	88	48
3 pcs.		(515)	(407)	292	191	127	63

Exhaust Noise (Reference value)

Exhaust noise [dB(A)]	Size 300 x 180	64
		Size 200 x 120

* Actual values under SMC's measurement conditions (Not guaranteed values)

Ejector Exhaust Characteristics (Reference value)*1

*1 Measured under SMC test conditions and are not guaranteed

Number of ejector assemblies: 1

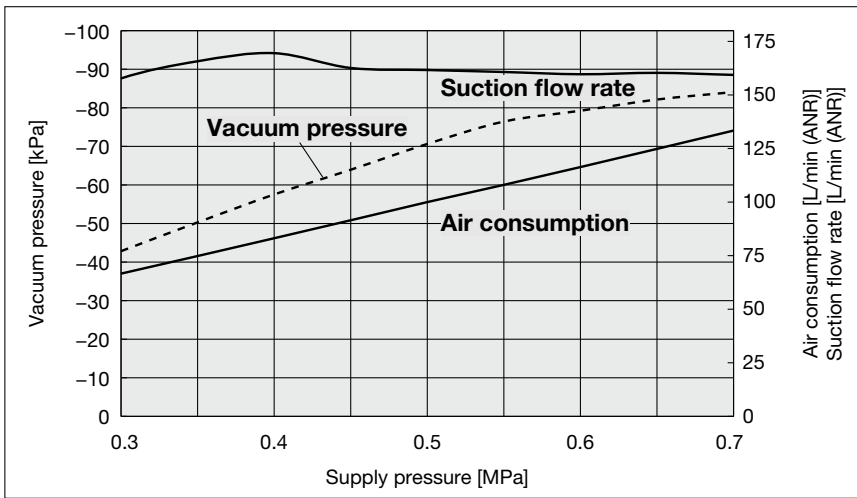

Number of ejector assemblies: 2

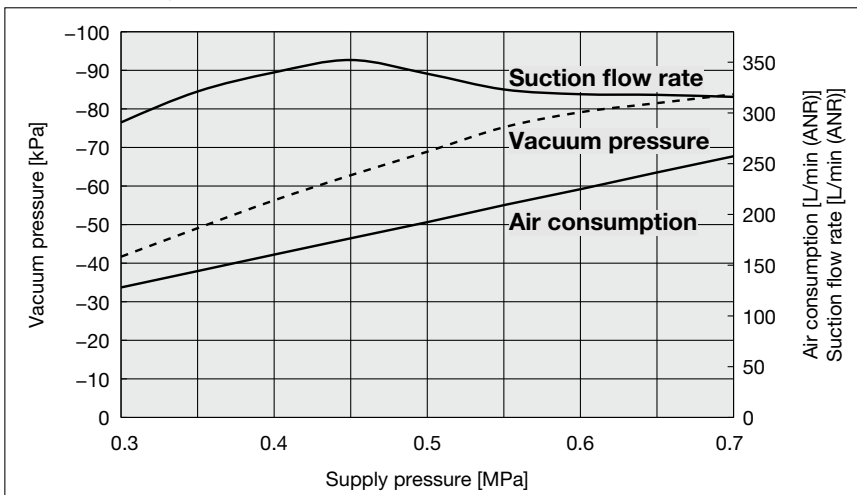

Number of ejector assemblies: 3

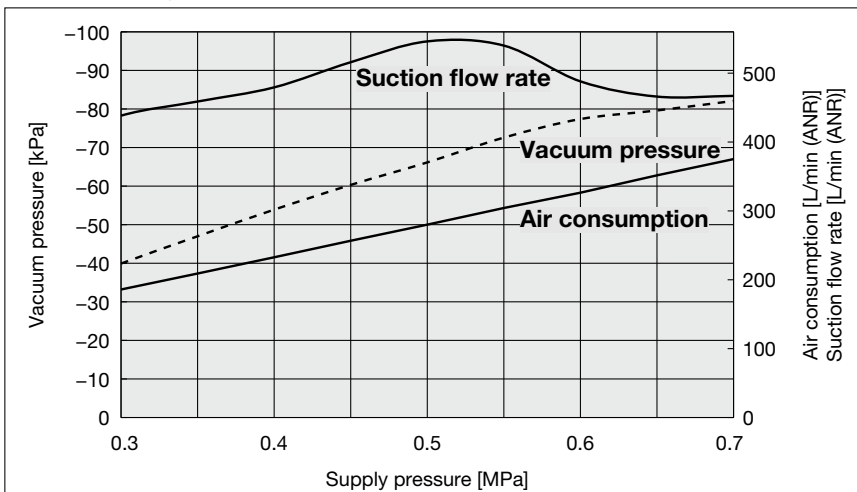

Dimensions: 300 mm x 180 mm

Robot mounting flange: Tool plate + Main plate
 Compatible robot: NP/NN/NH (General purpose)
 011P (UNIVERSAL ROBOTS)
 051P (FANUC)

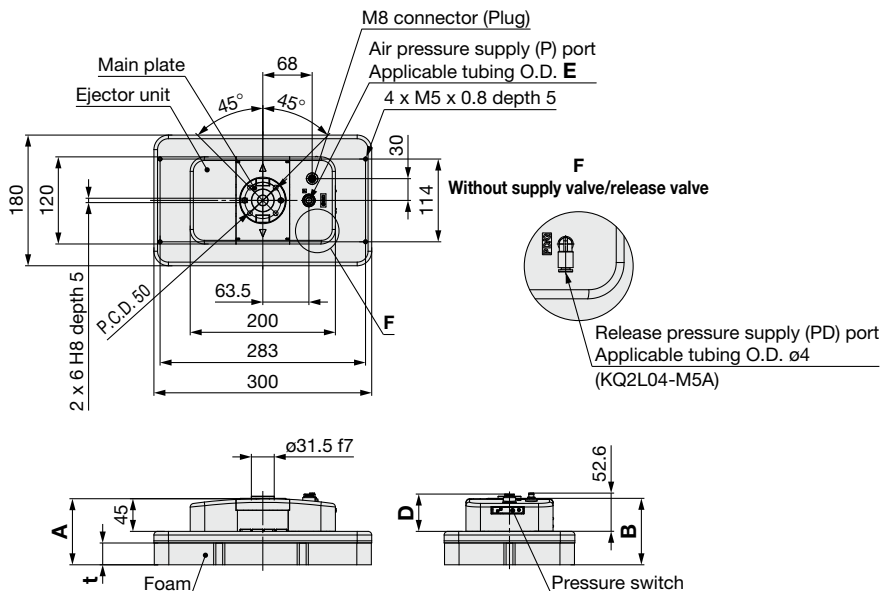

Part no.	t	A	B
ZGS□□-300180A□□-□□1□	20	81	81.5
ZGS□□-300180B□□-□□1□	30	91	91.5

Part no.	D	E
ZGS□□-300180□□□-□□□C8	51.4	ø8
ZGS□□-300180□□□-□□□C10	52	ø10
ZGS□□-300180□□□-□□□N9	51.4	ø5/16"
ZGS□□-300180□□□-□□□N11	51.9	ø3/8"

Robot mounting flange: Tool plate + Main plate + Flange Y
 Compatible robot: 043P/043N (YASKAWA Electric)

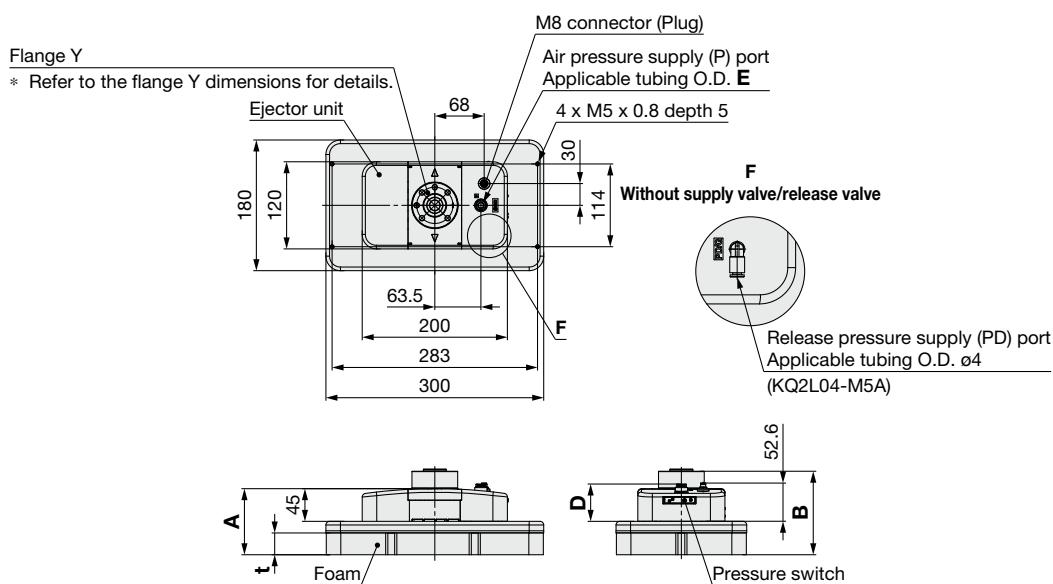

Part no.	t	A	B
ZGS043(P/N)□-300180A□□-□□1□	20	81	105
ZGS043(P/N)□-300180B□□-□□1□	30	91	115

Part no.	D	E
ZGS□□-300180□□□-□□□C8	51.4	ø8
ZGS□□-300180□□□-□□□C10	52	ø10
ZGS□□-300180□□□-□□□N9	51.4	ø5/16"
ZGS□□-300180□□□-□□□N11	51.9	ø3/8"

Foam Size: 400 mm x 240 mm

Foam Size: 300 mm x 180 mm
 Foam Size: 200 mm x 120 mm

Connector Cable
 Robot Mounting Flange

ZGS Series

Dimensions: 300 mm x 180 mm

Robot mounting flange: Tool plate + Main plate + Flange U

Compatible robot: 012P (UNIVERSAL ROBOTS UR20)

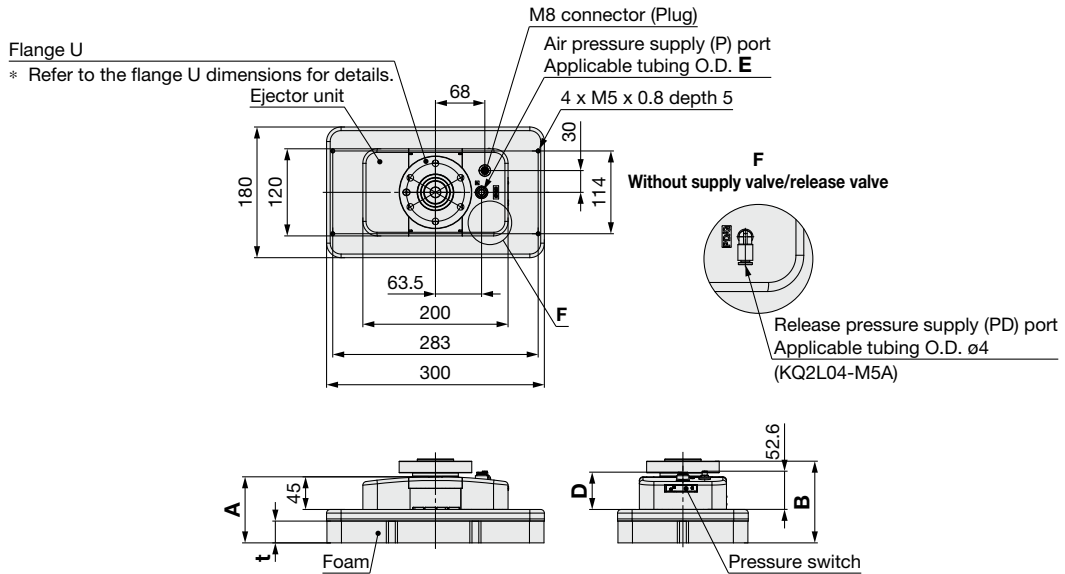

Part no.	t	A	B
ZGS012P□-300180A□□-□□1□	20	81	102.5
ZGS012P□-300180B□□-□□1□	30	91	112.5

Part no.	D	E
ZGS□□-300180□□□-□□□C8	51.4	$\phi 8$
ZGS□□-300180□□□-□□□C10	52	$\phi 10$
ZGS□□-300180□□□-□□□N9	51.4	$\phi 5/16"$
ZGS□□-300180□□□-□□□N11	51.9	$\phi 3/8"$

Robot mounting flange: Offset flange

Compatible robot: NP/NN/NH (General purpose)

011P (UNIVERSAL ROBOTS)

051P (FANUC)

021N (OMRON/TECHMAN ROBOT)

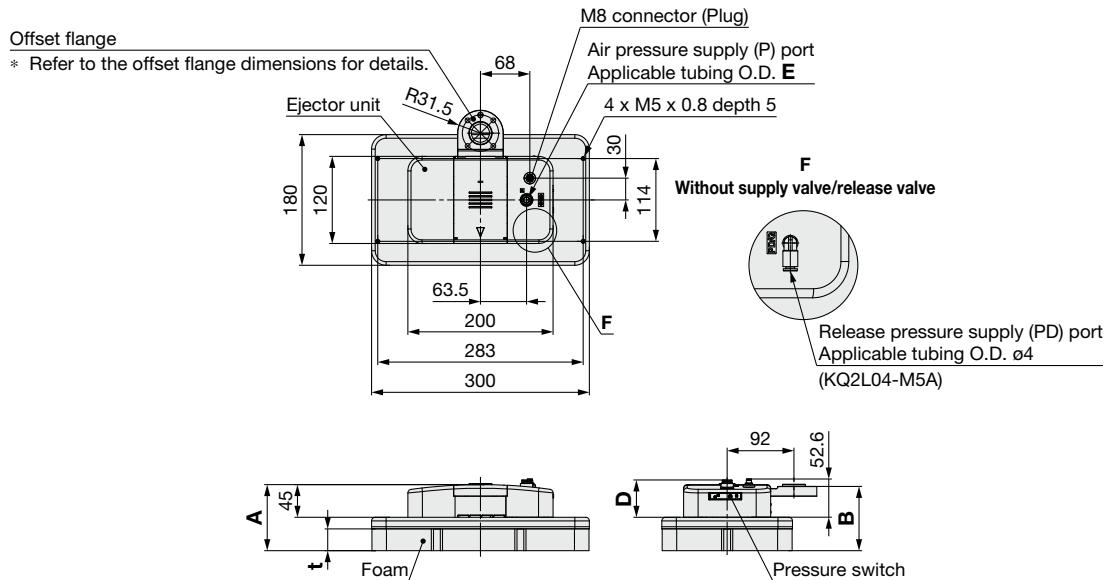

Part no.	t	A	B
ZGS□□-300180A□□-□□2□	20	81	78.5
ZGS□□-300180B□□-□□2□	30	91	88.5

Part no.	D	E
ZGS□□-300180□□□-□□□C8	51.4	$\phi 8$
ZGS□□-300180□□□-□□□C10	52	$\phi 10$
ZGS□□-300180□□□-□□□N9	51.4	$\phi 5/16"$
ZGS□□-300180□□□-□□□N11	51.9	$\phi 3/8"$

Dimensions: 300 mm x 180 mm

Robot mounting flange: Offset flange + Flange U
Compatible robot: 012P (UNIVERSAL ROBOTS UR20)

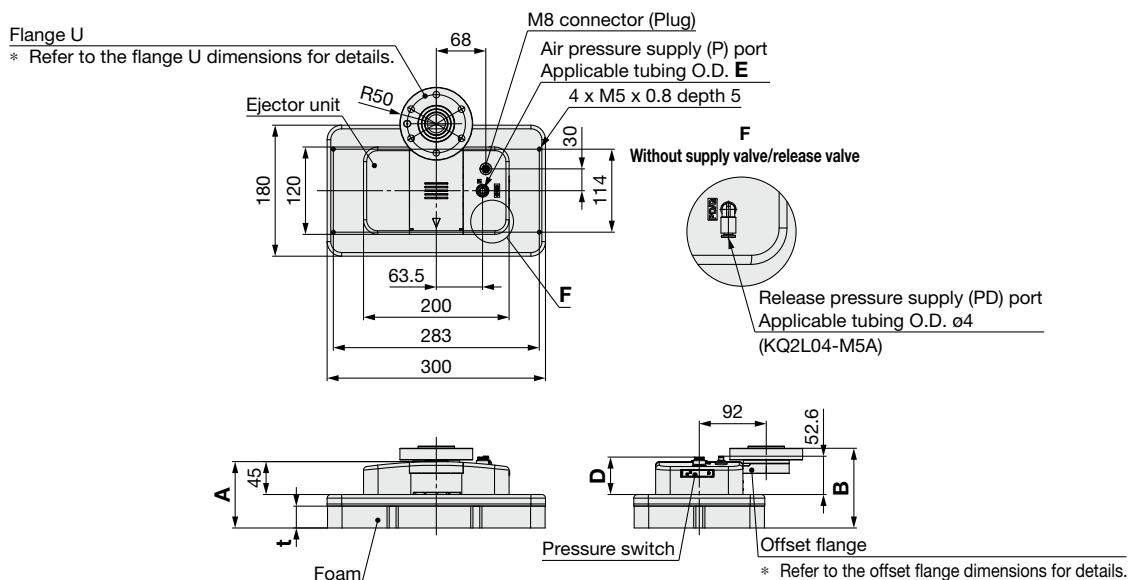

Part no.	t	A	B
ZGS012P□-300180A□□-□□2□	20	81	99.5
ZGS012P□-300180B□□-□□2□	30	91	109.5

Part no.	D	E
ZGS□□-300180□□□-□□□C8	51.4	ø8
ZGS□□-300180□□□-□□□C10	52	ø10
ZGS□□-300180□□□-□□□N9	51.4	ø5/16"
ZGS□□-300180□□□-□□□N11	51.9	ø3/8"

Robot mounting flange: Offset flange + Flange Y
Compatible robot: 043P/043N (YASKAWA Electric)

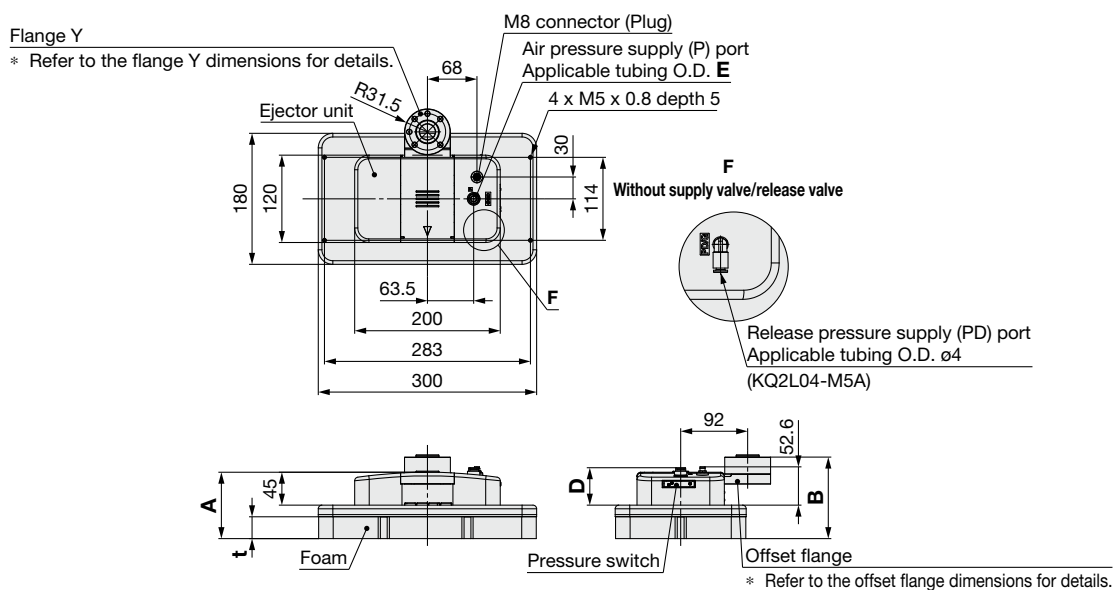

Part no.	t	A	B
ZGS043(P/N)□-300180A□□-□□2□	20	81	102
ZGS043(P/N)□-300180B□□-□□2□	30	91	112

Part no.	D	E
ZGS□□-300180□□□-□□□C8	51.4	ø8
ZGS□□-300180□□□-□□□C10	52	ø10
ZGS□□-300180□□□-□□□N9	51.4	ø5/16"
ZGS□□-300180□□□-□□□N11	51.9	ø3/8"

Foam Size: 400 mm x 240 mm

Foam Size: 300 mm x 180 mm
 Foam Size: 200 mm x 120 mm

Connector Cable
 Robot Mounting Flange

ZGS Series

Dimensions: 300 mm x 180 mm

Without robot mounting flange

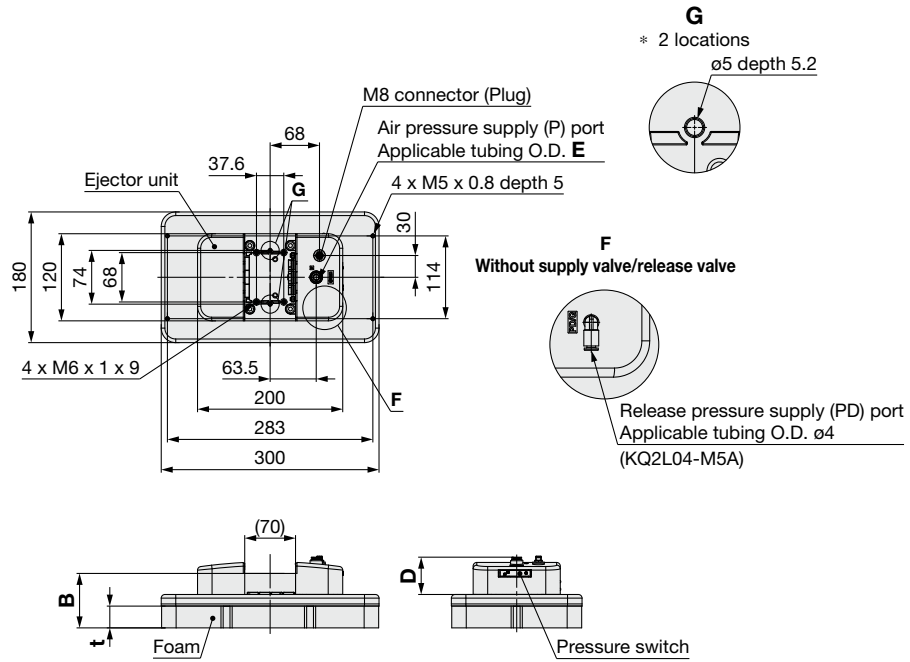

Part no.	t	B
ZGS□□-300180A□□-□□□□	20	65
ZGS□□-300180B□□-□□□□	30	75

Part no.	D	E
ZGS□□-300180□□□-□□□□C8	51.4	$\phi 8$
ZGS□□-300180□□□-□□□□C10	52	$\phi 10$
ZGS□□-300180□□□-□□□□N9	51.4	$\phi 5/16"$
ZGS□□-300180□□□-□□□□N11	51.9	$\phi 3/8"$

Dimensions: 200 mm x 120 mm

Robot mounting flange: Tool plate + Main plate
 Compatible robot: NP/NN/NH (General purpose)
 011P (UNIVERSAL ROBOTS)
 051P (FANUC)

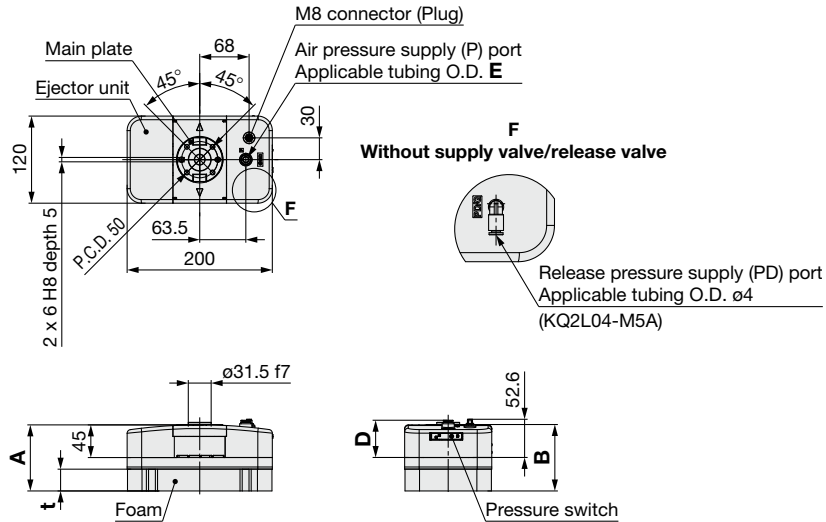

Part no.	t	A	B
ZGS□□-200120A□□-□□1□	20	81	81.5
ZGS□□-200120B□□-□□1□	30	91	91.5

Part no.	D	E
ZGS□□-200120□□□-□□□C8	51.4	ø8
ZGS□□-200120□□□-□□□C10	52	ø10
ZGS□□-200120□□□-□□□N9	51.4	ø5/16"
ZGS□□-200120□□□-□□□N11	51.9	ø3/8"

Robot mounting flange: Tool plate + Main plate + Flange Y
 Compatible robot: 043P/043N (YASKAWA Electric)

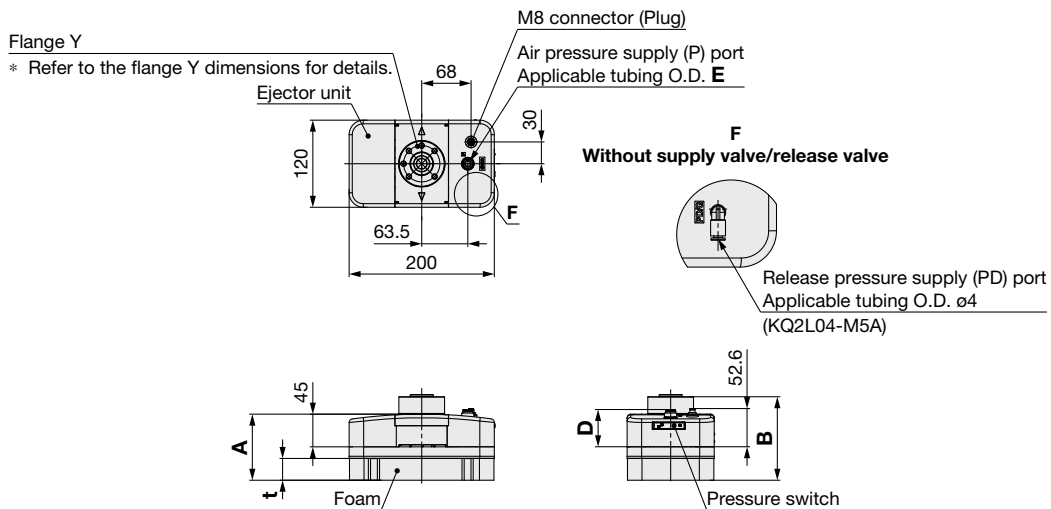

Part no.	t	A	B
ZGS043(P/N)□-200120A□□-□□1□	20	81	105
ZGS043(P/N)□-200120B□□-□□1□	30	91	115

Part no.	D	E
ZGS□□-200120□□□-□□□C8	51.4	ø8
ZGS□□-200120□□□-□□□C10	52	ø10
ZGS□□-200120□□□-□□□N9	51.4	ø5/16"
ZGS□□-200120□□□-□□□N11	51.9	ø3/8"

Foam Size: 400 mm x 240 mm

Foam Size: 300 mm x 180 mm
 Foam Size: 200 mm x 120 mm

Connector Cable
 Robot Mounting Flange

ZGS Series

Dimensions: 200 mm x 120 mm

Robot mounting flange: Tool plate + Main plate + Flange U

Compatible robot: 012P (UNIVERSAL ROBOTS UR20)

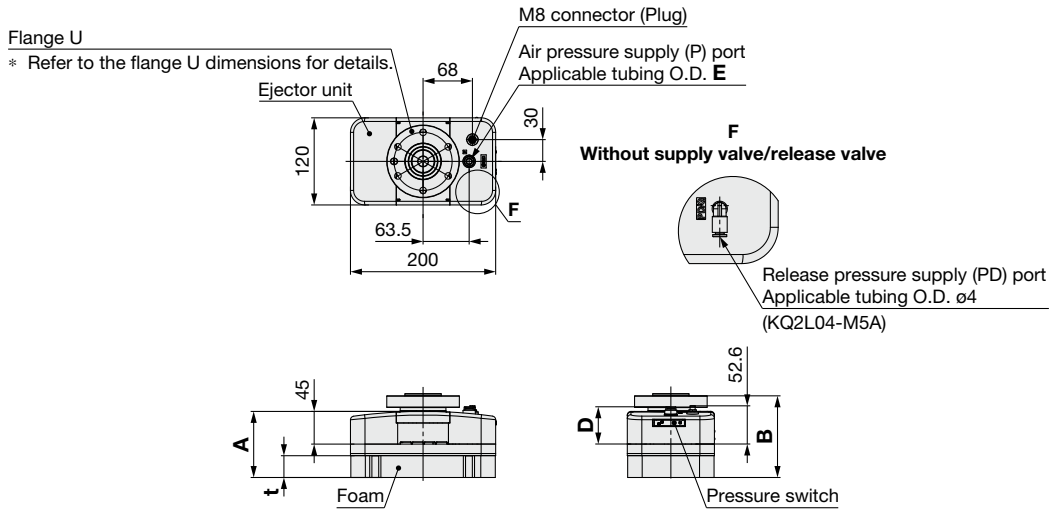

Part no.	t	A	B
ZGS012P□-200120A□□-□□1□	20	81	102.5
ZGS012P□-200120B□□-□□1□	30	91	112.5

Part no.	D	E
ZGS□□-200120□□□-□□□C8	51.4	ø8
ZGS□□-200120□□□-□□□C10	52	ø10
ZGS□□-200120□□□-□□□N9	51.4	ø5/16"
ZGS□□-200120□□□-□□□N11	51.9	ø3/8"

Robot mounting flange: Offset flange

Compatible robot: NP/NN/NH (General purpose)

011P (UNIVERSAL ROBOTS)

051P (FANUC)

021N (OMRON/TECHMAN ROBOT)

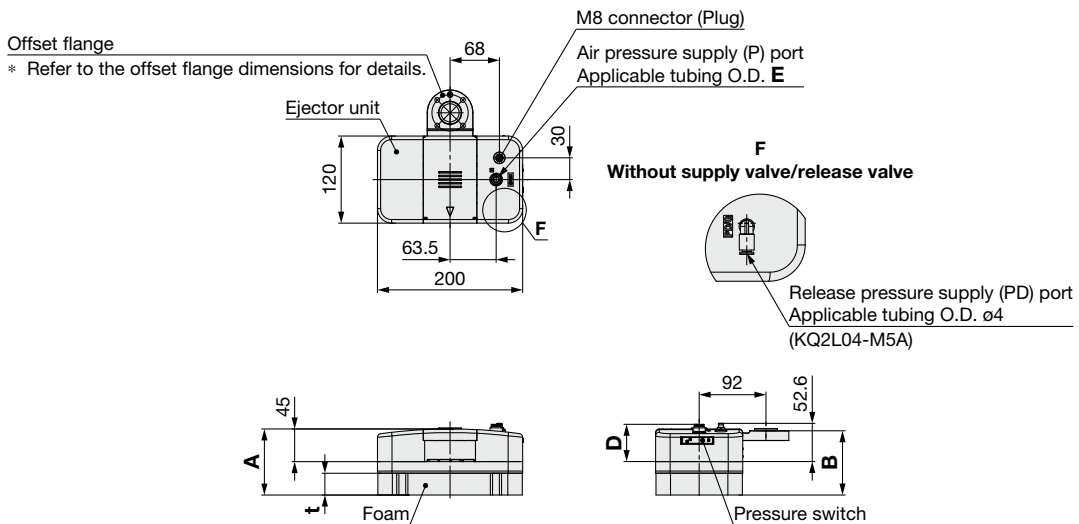

Part no.	t	A	B
ZGS□□-200120A□□-□□2□	20	81	78.5
ZGS□□-200120B□□-□□2□	30	91	88.5

Part no.	D	E
ZGS□□-200120□□□-□□□C8	51.4	ø8
ZGS□□-200120□□□-□□□C10	52	ø10
ZGS□□-200120□□□-□□□N9	51.4	ø5/16"
ZGS□□-200120□□□-□□□N11	51.9	ø3/8"

Dimensions: 200 mm x 120 mm

Robot mounting flange: Offset flange + Flange U
Compatible robot: 012P (UNIVERSAL ROBOTS UR20)

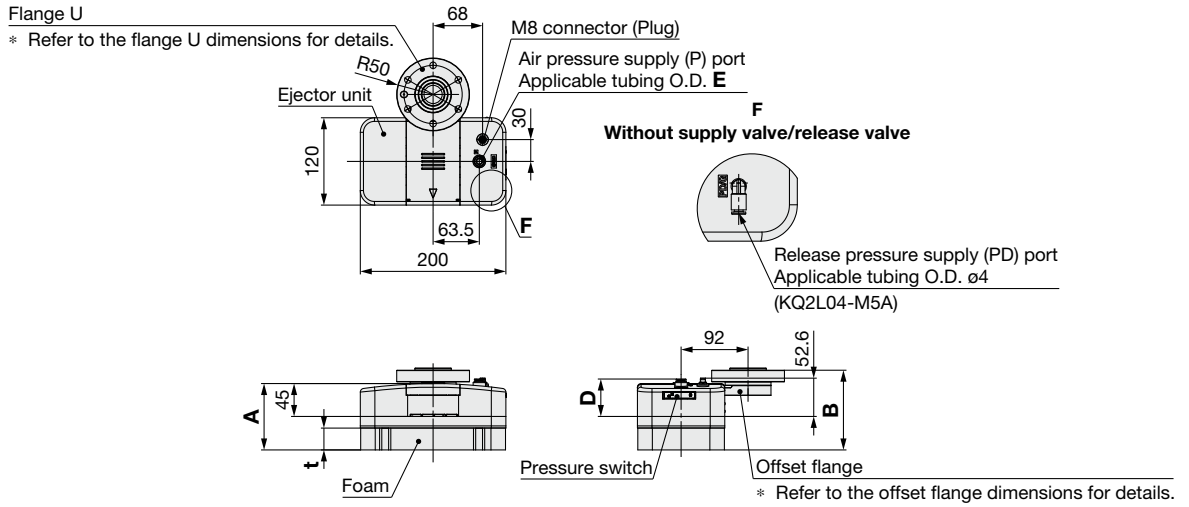

Part no.	t	A	B
ZGS012P□-200120A□□-□□2□	20	81	99.5
ZGS012P□-200120B□□-□□2□	30	91	109.5

Part no.	D	E
ZGS□□-200120□□□□-□□□□C8	51.4	ø8
ZGS□□-200120□□□□-□□□□C10	52	ø10
ZGS□□-200120□□□□-□□□□N9	51.4	ø5/16"
ZGS□□-200120□□□□-□□□□N11	51.9	ø3/8"

Robot mounting flange: Offset flange + Flange Y
Compatible robot: 043P/043N (YASKAWA Electric)

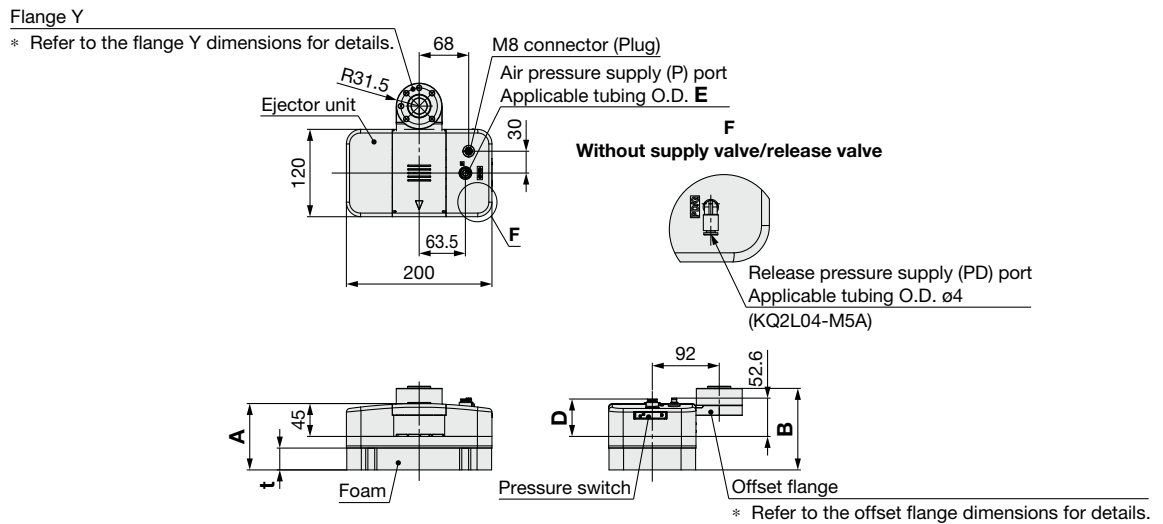

Part no.	t	A	B
ZGS043(P/N)□-200120A□□-□□2□	20	81	102
ZGS043(P/N)□-200120B□□-□□2□	30	91	112

Part no.	D	E
ZGS□□-200120□□□□-□□□□C8	51.4	ø8
ZGS□□-200120□□□□-□□□□C10	52	ø10
ZGS□□-200120□□□□-□□□□N9	51.4	ø5/16"
ZGS□□-200120□□□□-□□□□N11	51.9	ø3/8"

Foam Size: 400 mm x 240 mm

Foam Size: 300 mm x 180 mm
 Foam Size: 200 mm x 120 mm

Connector Cable
 Robot Mounting Flange

ZGS Series

Dimensions: 200 mm x 120 mm

Without robot mounting flange

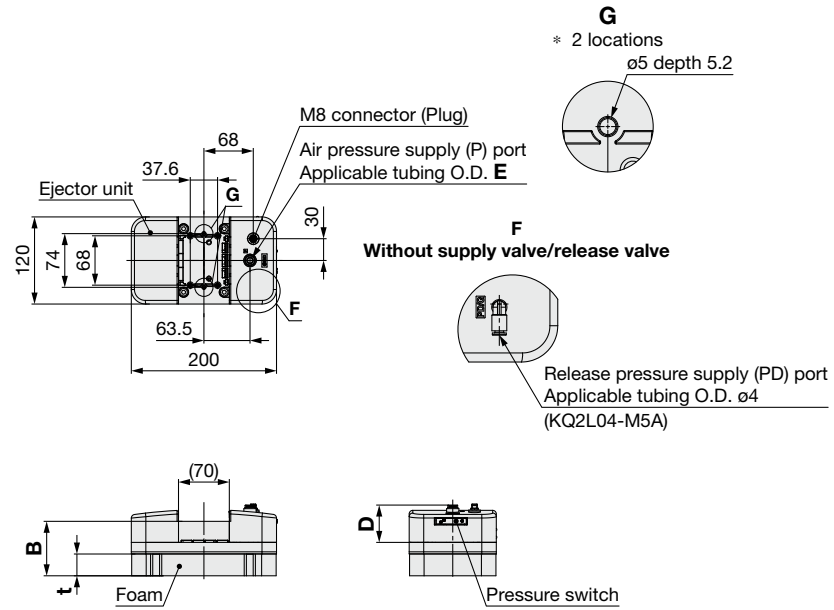

Part no.	t	B
ZGS□□-200120A□□-□□□	20	65
ZGS□□-200120B□□-□□□	30	75

Part no.	D	E
ZGS□□-200120□□□-□□□C8	51.4	$\phi 8$
ZGS□□-200120□□□-□□□C10	52	$\phi 10$
ZGS□□-200120□□□-□□□N9	51.4	$\phi 5/16"$
ZGS□□-200120□□□-□□□N11	51.9	$\phi 3/8"$

Dimensions

Main plate

Compatible robot: NP/NN/NH (General purpose)
 011P/012P (UNIVERSAL ROBOTS)
 043P/043N (YASKAWA Electric)
 051P (FANUC)

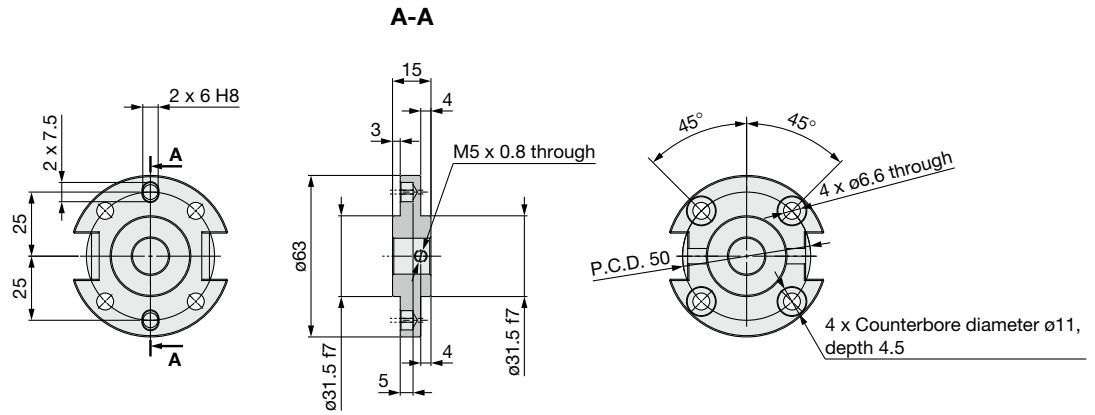

Tool plate

Compatible robot: NP/NN/NH (General purpose)
 011P/012P (UNIVERSAL ROBOTS)
 043P/043N (YASKAWA Electric)
 051P (FANUC)

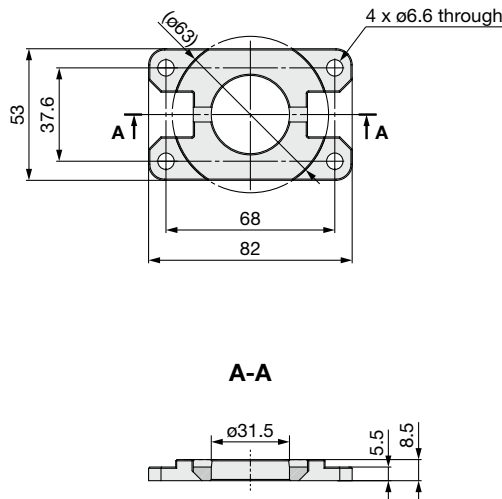

Foam Size: 400 mm x 240 mm

Foam Size: 300 mm x 180 mm
 Foam Size: 200 mm x 120 mm

Connector Cable
 Robot Mounting Flange

ZGS Series

Dimensions

Flange Y

Compatible robot: 043P/043N (YASKAWA Electric)

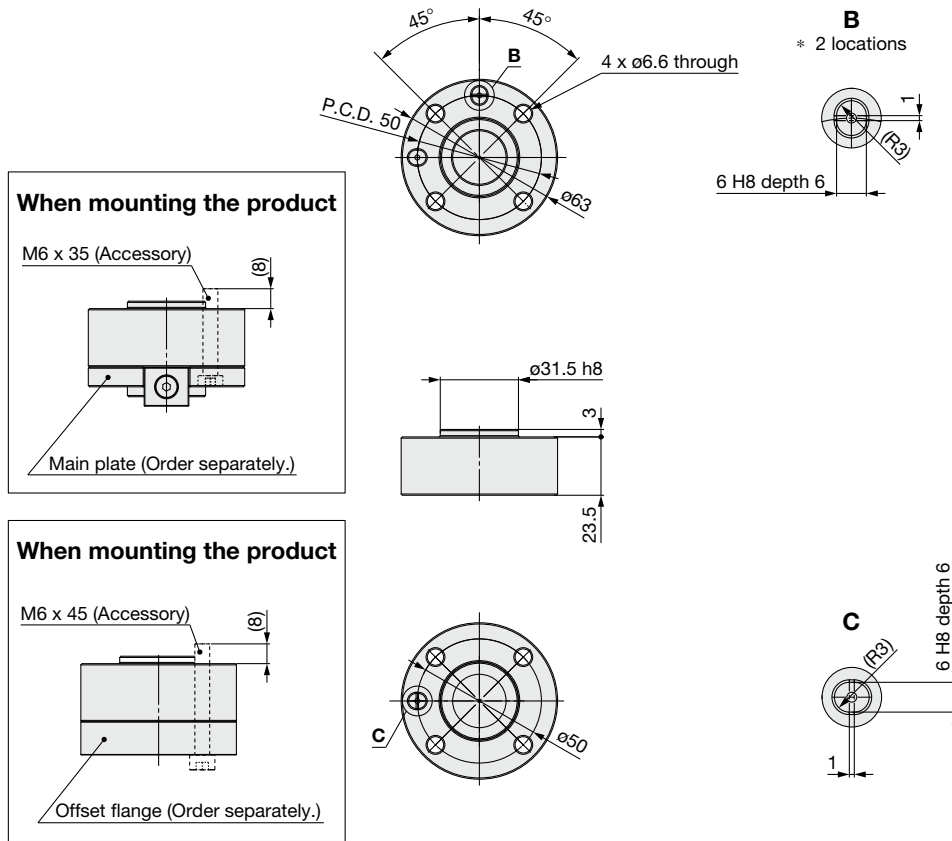

Flange U

Compatible robot: 012P (UNIVERSAL ROBOTS UR20)

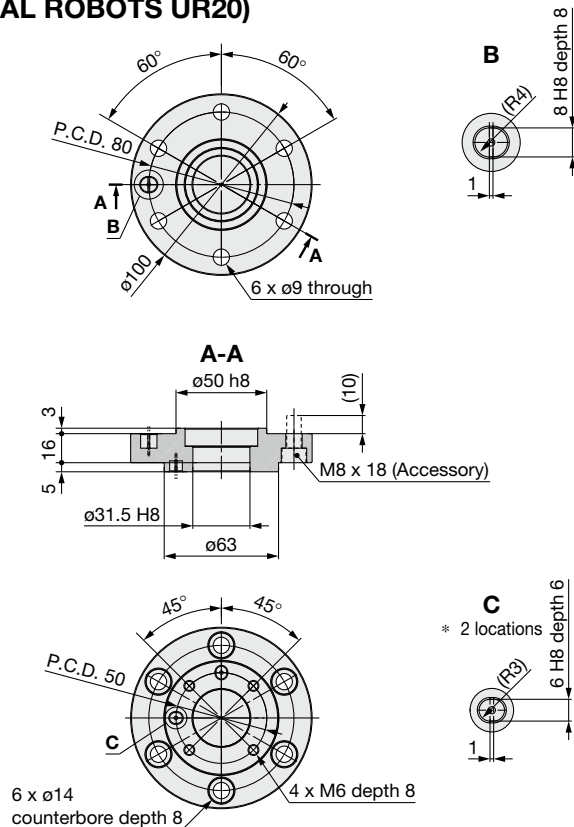

Dimensions

Offset flange

Compatible robot: 021N (OMRON/TECHMAN ROBOT)

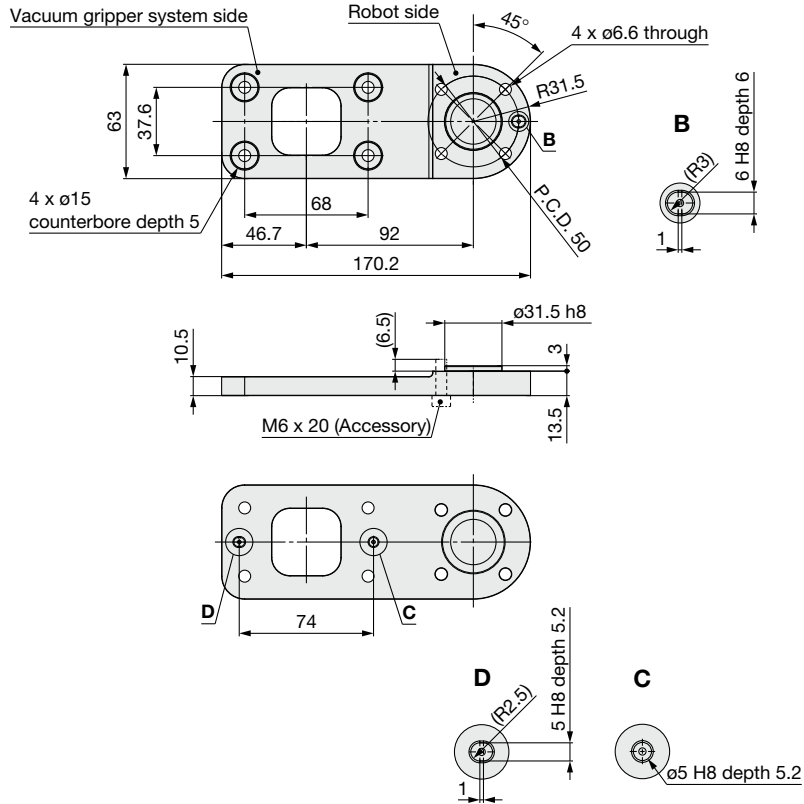

Foam Size: 400 mm x 240 mm

Foam Size: 300 mm x 180 mm
Foam Size: 200 mm x 120 mm

Connector Cable
Robot Mounting Flange

ZGS Series

Connector Cable for Compatible Robot

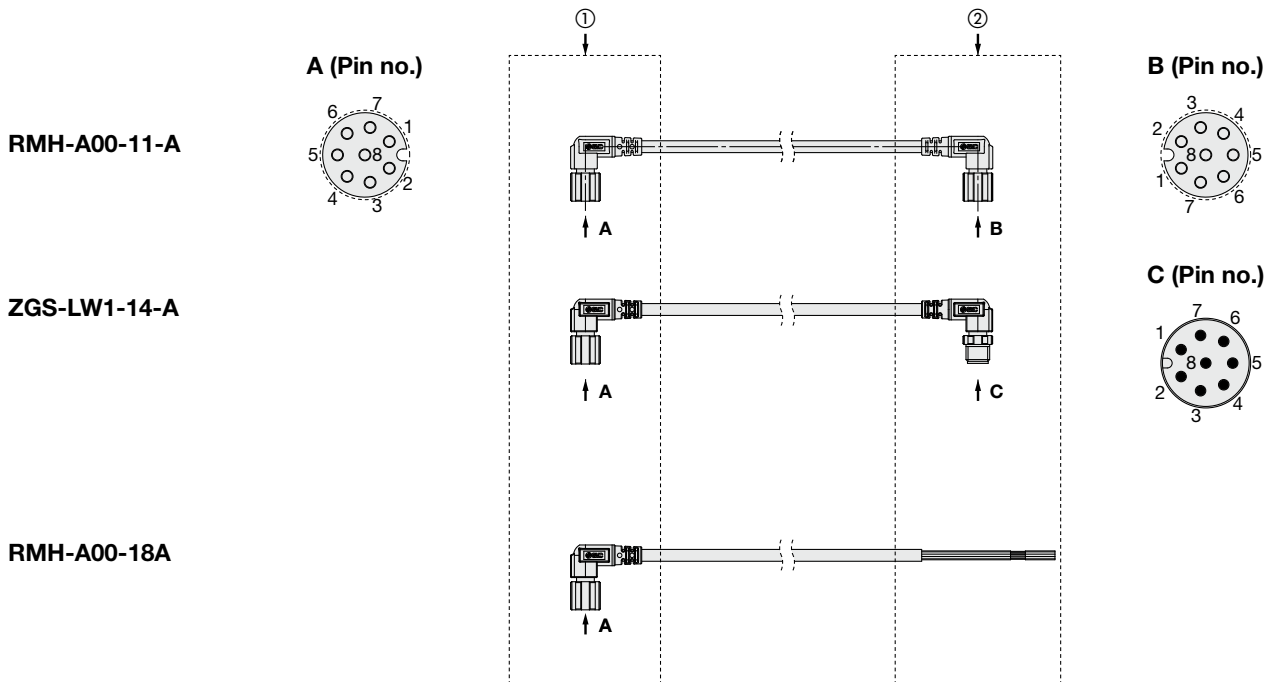

Symbol	Robot manufacturer	① Vacuum gripper system side	② Robot side	Part no.	Cable length [mm]	
011P	UNIVERSAL ROBOTS	M8 8-pin connector (Socket)	M8 8-pin connector (Socket)	RMH-A00-11-A	220	
012P*1						
043P	YASKAWA Electric		M8 8-pin connector (Socket)	RMH-A00-11-A	220	
043N						
051P	FANUC					
NP	—			Discrete wire	RMH-A00-18A	3000
NN	—					
021N	OMRON/TECHMAN ROBOT		M8 8-pin connector (Plug)	ZGS-LW1-14-A	300	
NH	—	M8 4-pin connector (Socket)	For customers already in possession of an M12 cable, be sure to prepare an M8 to M12 conversion connector.			

*1 For UR20, please also use it in conjunction with the tool cable adapter that comes with the robot.

Robot Mounting Flange (Foam Size: 400 mm x 240 mm)

	Description	Quantity	Note
ZGS-PL3-1-A Basic type (Conforming to ISO 9409-1-50-4-M6)	Robot mounting flange Basic type	1	
	Parallel pin (ø6 x 10)	1	For securing the robot flange to the robot*1
	Hexagon socket head cap screw (M6 x 18)	4	
	Parallel pin (ø8 x 15)	1	For securing the robot flange to the robot*1
	Hexagon socket head cap screw (M8 x 20)	6	
	Parallel pin (ø5 x 10)	2	For securing the robot flange to the ejector unit
	Hexagon socket head cap screw (M6 x 14)	8	
Flat washer (M6)	8		
ZGS-PL5-1-A Offset flange	Offset flange	1	
	Parallel pin (ø6 x 10)	1	For securing the offset flange to the robot
	Hexagon socket head cap screw (M6 x 23)	4	

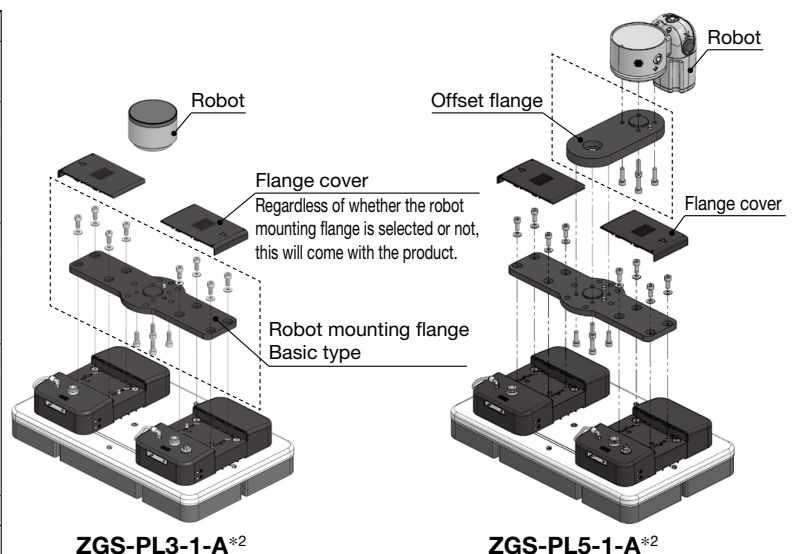

*2 The parts within the dotted lines are included with the product.

*1 Select the most suitable option for the robot to be used.

Robot Mounting Flange (Foam Size: 300 mm x 180 mm, 200 mm x 120 mm)

Tool plate + Main plate

Compatible robot:

NP/NN/NH (General purpose)

011P (UNIVERSAL ROBOTS)

051P (FANUC)

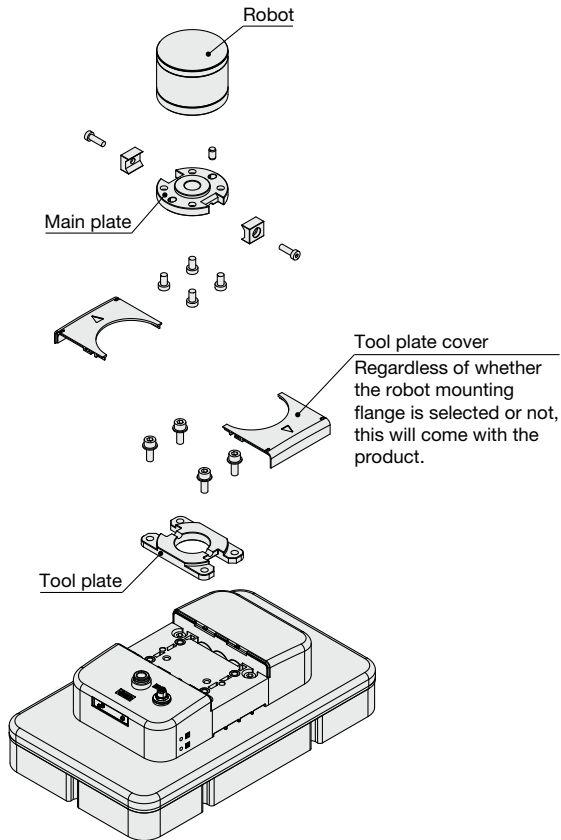

	Description	Qty.	Note
ZGS-PL3-7-A Main plate	Main plate	1	
	Clamper	2	
	Hexagon socket thin head cap screw (M5 x 25)	2	For securing the clamper
	Hexagon socket thin head cap screw (M6 x 10)	4	For securing the main plate to the robot
	Parallel pin (6 x 10)	1	
ZGS-PL3-3-A Tool plate	Tool plate	1	
	Hexagon socket head cap screw (M6 x 16)	4	For securing the tool plate to the ejector unit
	Flat washer (M6)	4	

Offset flange

Compatible robot:

NP/NN/NH (General purpose)

011P (UNIVERSAL ROBOTS)

051P (FANUC)

021N (OMRON/TECHMAN ROBOT)

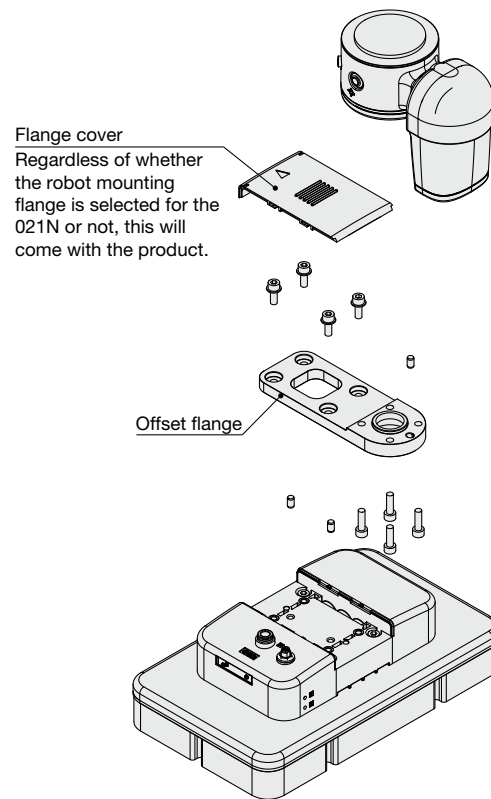

	Description	Qty.	Note
ZGS-PL3-4-A Offset flange	Offset flange	1	
	Hexagon socket head cap screw (M6 x 16)	4	For securing the offset flange to the ejector unit
	Flat washer (M6)	4	
	Parallel pin (5 x 10)	2	
	Parallel pin (6 x 10)	1	For securing the offset flange to the robot
	Hexagon socket head cap screw (M6 x 20)	4	

Foam Size: 400 mm x 240 mm

Foam Size: 300 mm x 180 mm
Foam Size: 200 mm x 120 mm

Connector Cable
Robot Mounting Flange

ZGS Series

Robot Mounting Flange (Foam Size: 300 mm x 180 mm, 200 mm x 120 mm)

Offset flange

Compatible robot:

012P (UNIVERSAL ROBOTS UR20)

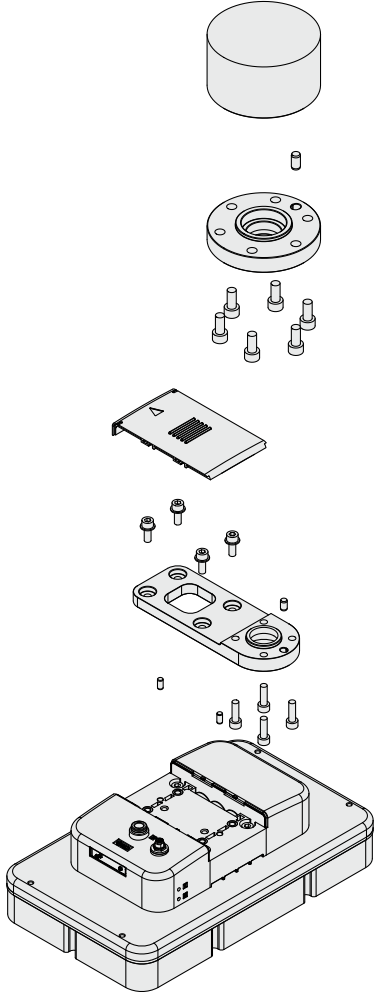

	Description	Qty.	Note
ZGS-PL3-5-A Flange U	Flange U	1	
	Hexagon socket head cap screw (M8 x 18)	6	For securing the flange U to the robot
	Parallel pin (8 x 15)	1	
ZGS-PL3-4-A Offset flange	Offset flange	1	
	Hexagon socket head cap screw (M6 x 16)	4	For securing the offset flange to the ejector unit
	Flat washer (M6)	4	
	Parallel pin (5 x 10)	2	For securing the flange U to the offset flange
	Parallel pin (6 x 10)	1	
	Hexagon socket head cap screw (M6 x 20)	4	

Offset flange

Compatible robot:

043P/043N (YASKAWA Electric)

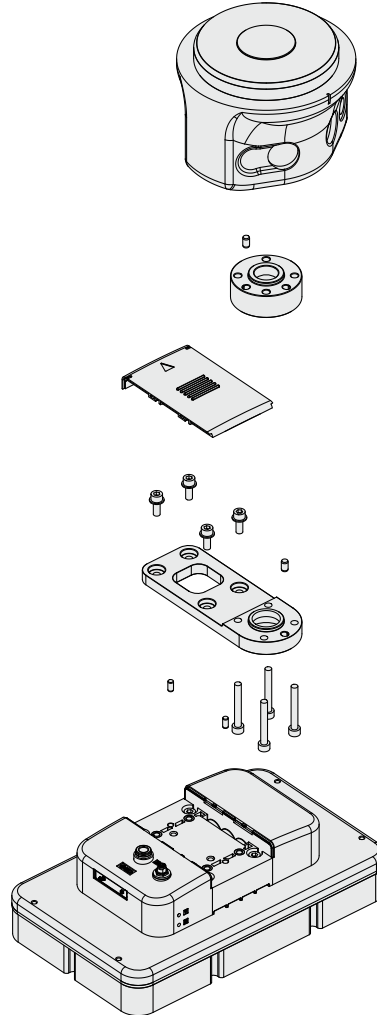

	Description	Qty.	Note
ZGS-PL3-6-1-A Flange Y	Flange Y	1	
	Hexagon socket head cap screw (M6 x 45)	4	For securing the flange Y + offset flange to the robot
	Parallel pin (6 x 10)	1	
ZGS-PL3-4-A Offset flange	Offset flange	1	
	Hexagon socket head cap screw (M6 x 16)	4	For securing the offset flange to the ejector unit
	Flat washer (M6)	4	
	Parallel pin (5 x 10)	2	For securing the flange Y to the offset flange
	Parallel pin (6 x 10)	1	
		Hexagon socket head cap screw (M6 x 20)	4

Robot Mounting Flange (Foam Size: 300 mm x 180 mm, 200 mm x 120 mm)

Tool plate + Main plate
Compatible robot:
012P (UNIVERSAL ROBOTS UR20)

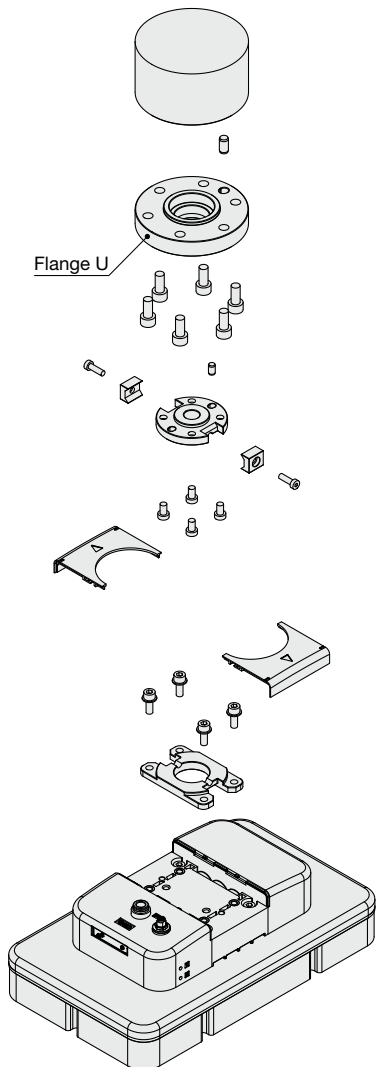

	Description	Qty.	Note
ZGS-PL3-5-A Flange U	Flange U	1	
	Hexagon socket head cap screw (M8 x 18)	6	For securing the flange U to the robot
	Parallel pin (8 x 15)	1	
ZGS-PL3-7-A Main plate	Main plate	1	
	Clamber	2	
	Hexagon socket thin head cap screw (M5 x 25)	2	For securing the clamber
	Hexagon socket thin head cap screw (M6 x 10)	4	For securing the main plate to the flange U
	Parallel pin (6 x 10)	1	
ZGS-PL3-3-A Tool plate	Tool plate	1	
	Hexagon socket head cap screw (M6 x 16)	4	For securing the tool plate to the ejector unit
	Flat washer (M6)	4	

Tool plate + Main plate
Compatible robot:
043P/043N (YASKAWA Electric)

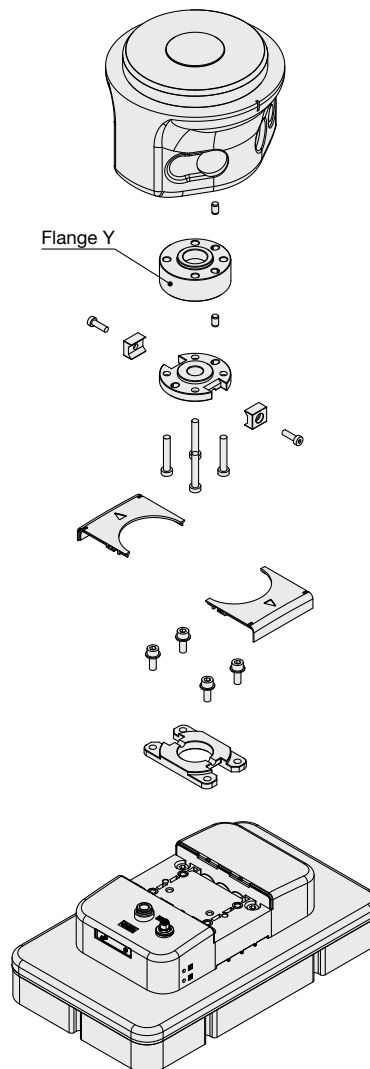

	Description	Qty.	Note
ZGS-PL3-6-A Flange Y	Flange Y	1	
	Hexagon socket thin head cap screw (M6 x 35)	4	For securing the flange Y + main plate to the robot
	Parallel pin (6 x 10)	1	For securing the flange Y to the robot
ZGS-PL3-7-A Main plate	Main plate	1	
	Clamber	2	
	Hexagon socket thin head cap screw (M5 x 25)	2	For securing the clamber
	Hexagon socket thin head cap screw (M6 x 10)	4	It comes with the product but is not used.
	Parallel pin (6 x 10)	1	For securing the main plate to the flange Y
ZGS-PL3-3-A Tool plate	Tool plate	1	
	Hexagon socket head cap screw (M6 x 16)	4	For securing the tool plate to the ejector unit
	Flat washer (M6)	4	

Foam Size: 400 mm x 240 mm

Foam Size: 300 mm x 180 mm
 Foam Size: 200 mm x 120 mm

Connector Cable
 Robot Mounting Flange



ZGS Series

Specific Product Precautions

Be sure to read this before handling the products. Refer to the back cover for safety instructions. For vacuum equipment precautions, refer to the “Handling Precautions for SMC Products” and the “Operation Manual” on the SMC website: <https://www.smcworld.com>

Handling

Warning

When the foam comes into contact with a workpiece, do not put a finger between the foam and the workpiece; it can be caught during suction.

Caution

- 1. Strictly observe the precautions on vacuum equipment and safety when using the product.**
Take safety measures so that any accident, such as the dropping of a workpiece, does not occur during adsorption transfer.
- 2. Use the product within the specification range.**
Use exceeding the voltage may result in serious damage due to reduced product performance.
- 3. Exhaust air is released from the opening in the product.**
Therefore, this exhaust air opening must not be blocked or restricted.
- 4. Before suction, press the foam onto the workpiece so that the foam adapts to the unevenness of the workpiece surface in order to avoid the suction failure.**
It is recommended that the foam is compressed to approximately 50% of its original thickness.
- 5. Do not pressurize the product with the ejector cover removed; ejector assembly may jump out.**

Environment

Warning

This product is not designed to be explosion proof, dustproof, or drip proof.

Do not use in an environment where flammable gas or explosive gas is present.

Caution

If liquids such as water, oil, or chemicals are adsorbed, it may accumulate inside the product causing damage and reducing the performance. Therefore, this product cannot be used in an environment where liquids such as water, oil content, or chemicals are present.

In addition, if the product adsorbs a workpiece that is adhered to such liquids, it will reduce the product life and require early maintenance. Do not use the product in a place where static electricity is a problem. Otherwise, failure or malfunction of the system can result.

Design

Warning

Design the equipment with safety in mind, taking into account a vacuum pressure drop caused by a power or air supply failure.

Provide preventive measures against the fall of workpieces where this may cause danger.

Maintenance

Warning

Perform maintenance inspection according to the procedures indicated in the operation manual.

If handled improperly, malfunction or damage of the product may occur.

Safety Instructions

These safety instructions are intended to prevent hazardous situations and/or equipment damage. These instructions indicate the level of potential hazard with the labels of “**Caution**,” “**Warning**” or “**Danger**.” They are all important notes for safety and must be followed in addition to International Standards (ISO/IEC)*1), and other safety regulations.

 **Danger :** **Danger** indicates a hazard with a high level of risk which, if not avoided, will result in death or serious injury.

 **Warning:** **Warning** indicates a hazard with a medium level of risk which, if not avoided, could result in death or serious injury.

 **Caution:** **Caution** indicates a hazard with a low level of risk which, if not avoided, could result in minor or moderate injury.

*1) ISO 4414: Pneumatic fluid power - General rules and safety requirements for systems and their components
ISO 4413: Hydraulic fluid power - General rules and safety requirements for systems and their components
IEC 60204-1: Safety of machinery - Electrical equipment of machines - Part 1: General requirements
ISO 10218-1: Robots and robotic devices - Safety requirements for industrial robots - Part 1: Robots etc.

Warning

1. The compatibility of the product is the responsibility of the person who designs the equipment or decides its specifications.

Since the product specified here is used under various operating conditions, its compatibility with specific equipment must be decided by the person who designs the equipment or decides its specifications based on necessary analysis and test results. The expected performance and safety assurance of the equipment will be the responsibility of the person who has determined its compatibility with the product. This person should also continuously review all specifications of the product referring to its latest catalog information, with a view to giving due consideration to any possibility of equipment failure when configuring the equipment.

2. Only personnel with appropriate training should operate machinery and equipment.

The product specified here may become unsafe if handled incorrectly. The assembly, operation and maintenance of machines or equipment including our products must be performed by an operator who is appropriately trained and experienced.

3. Do not service or attempt to remove product and machinery/equipment until safety is confirmed.

1. The inspection and maintenance of machinery/equipment should only be performed after measures to prevent falling or runaway of the driven objects have been confirmed.
2. When the product is to be removed, confirm that the safety measures as mentioned above are implemented and the power from any appropriate source is cut, and read and understand the specific product precautions of all relevant products carefully.
3. Before machinery/equipment is restarted, take measures to prevent unexpected operation and malfunction.

4. SMC products cannot be used beyond their specifications. They are not developed, designed, and manufactured to be used under the following conditions or environments. Use under such conditions or environments is not allowed.

1. Conditions and environments outside of the given specifications, or use outdoors or in a place exposed to direct sunlight.
2. Use for nuclear power, railways, aviation, space equipment, ships, vehicles, military application, equipment affecting human life, body, and property, combustion equipment, entertainment equipment, emergency shut-off circuits, press clutches, brake circuits, safety equipment, etc., and use for applications that do not conform to standard specifications such as catalogs and operation manuals.
3. Use for interlock circuits, except for use with double interlock such as installing a mechanical protection function in case of failure. Please periodically inspect the product to confirm that the product is operating properly.

Caution

SMC develops, designs, and manufactures products to be used for automatic control equipment, and provides them for peaceful use in manufacturing industries.

Use in non-manufacturing industries is not allowed.

Products SMC manufactures and sells cannot be used for the purpose of transactions or certification specified in the Measurement Act of each country. The new Measurement Act prohibits use of any unit other than SI units in Japan.

Limited warranty and Disclaimer/ Compliance Requirements

The product used is subject to the following “Limited warranty and Disclaimer” and “Compliance Requirements”.

Read and accept them before using the product.

Limited warranty and Disclaimer

1. The warranty period of the product is 1 year in service or 1.5 years after the product is delivered, whichever is first.*2)
Also, the product may have specified durability, running distance or replacement parts. Please consult your nearest sales branch.
2. For any failure or damage reported within the warranty period which is clearly our responsibility, a replacement product or necessary parts will be provided.
This limited warranty applies only to our product independently, and not to any other damage incurred due to the failure of the product.
3. Prior to using SMC products, please read and understand the warranty terms and disclaimers noted in the specified catalog for the particular products.

*2) **Suction cups (Vacuum pads) are excluded from this 1 year warranty.**

A suction cup (vacuum pad) is a consumable part, so it is warranted for a year after it is delivered.

Also, even within the warranty period, the wear of a product due to the use of the suction cup (vacuum pad) or failure due to the deterioration of rubber material are not allowed by the limited warranty.

Compliance Requirements

1. The use of SMC products with production equipment for the manufacture of weapons of mass destruction (WMD) or any other weapon is strictly prohibited.
2. The exports of SMC products or technology from one country to another are governed by the relevant security laws and regulations of the countries involved in the transaction. Prior to the shipment of a SMC product to another country, assure that all local rules governing that export are known and followed.

Revision History

Edition B * Foam sizes 300 mm x 180 mm and 200 mm x 120 mm have been added.
* The number of pages has been increased from 16 to 40.

 **Safety Instructions** Be sure to read the “Handling Precautions for SMC Products” (M-E03-3) and “Operation Manual” before use.