



Series 10-IDG□A

Standard dew point -20°C, -15°C, -40°C, -60°C

Membrane Air Dryer/Single Unit Type

How to Order



Clean series

10-IDG 30 □ A - □ 03 □ - □

Size

30
50
60
75
100

Standard dew point temperature/Outlet air flow rate

Symbol	Standard dew point (°C)	Flow rate by size, Outlet air flow rate (L/min [ANRI])				
		30	50	60	75	100
Nil	-20	300	500	Select from Series 10-IDG (Page 950)		
H	-15	300	500			
L	-40	75	110	170	240	300
S	-60	—	—	50	100	150

Thread type

Symbol	Type
Nil	Rc
N	NPT
F	G

Symbol



Bracket Assembly (Accessory)/Part No.

Part no.	Applicable model
10-BM64	10-IDG30□A, 10-IDG50□A
10-BM65	10-IDG60□A, 10-IDG75□A, 10-IDG100□A

* With hexagon socket head cap screws (2 pcs.) and spring washers (2 pcs.)

Semi-standard

Symbol	Specifications
Nil	None (Standard)
R	Flow direction (Right → Left)

Accessory

Symbol	Specifications
Nil	None (Standard)
B	With bracket

Note) When B is designated, a bracket assembly with a part number shown to the left below is included as an accessory.

Port size

Symbol	Port size	Size				
		30	50	60	75	100
02	1/4	●	●	—	—	—
03	3/8	●	●	●	●	●
04	1/2	—	—	●	●	●



Series 10-IDG

Membrane Air Dryer
Single Unit Type

RoHS

How to Order

10-IDG 10 - - 02 - -

Clean series

Size

3
5
10
20
60
75
100



Standard dew point temperature/Outlet air flow rate

Symbol	Standard dew point (°C)	Flow rate by size, Outlet air flow rate (L/min [ANR])						
		3	5	10	20	60	75	100
Nil	-20	25	50	100	200	600	750	1000
H	-15	25	50	100	200	600	750	1000
L	-40	—	—	—	—	Select from Series 10-IDG□A (Page 949)		
S	-60	—	—	—	—	Series 10-IDG□A (Page 949)		

Accessory

Symbol	Specifications
Nil	None (Standard)
B	With bracket

Note) When B is designated, a bracket assembly with a part number shown to the left below is included as an accessory.

Port size/Applicable tubing O.D.

Symbol	Port size	Piping type	Size						
			3	5	10	20	60	75	100
01	1/8	Thread	●	●	—	—	—	—	—
02	1/4		●	●	●	●	—	—	—
03	3/8		—	—	●	●	●	—	—
04	1/2		—	—	—	—	●	●	●

Thread type/One-touch fitting

Symbol	Type
Nil	Rc
N	NPT
F	G

Symbol

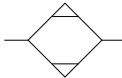

Bracket Assembly (Accessory)/Part No.

Part no.	Applicable model
10-BM59	10-IDG3□, 10-IDG5□
10-BM61	10-IDG10□
10-BM63	10-IDG20□
10-BM65	10-IDG60□, 10-IDG75□, 10-IDG100□

* With hexagon socket head cap screws (2 pcs.) and spring washers (2 pcs.)

Semi-standard

Symbol	Specifications	Size						
		3	5	10	20	60	75	100
Nil	None (Standard)	●	●	●	●	●	●	●
R	Flow direction (Right → Left)	●	●	●	●	●	●	●
S	With dew point indicator	●	●	Standard equipment				

Note) In the case of more than one symbol, indicate them alphabetically.

Directional Control Valves

Air Cylinders

Rotary Actuators

Air Grippers

Air Preparation Equipment

Modular F. R.

Pressure Control Equipment

Fittings & Tubing

Flow Control Equipment

Pressure Switches/ Pressure Sensors

Standard Specifications/Single Unit Type (Standard dew point -20°C, -15°C)

Standard dew point----20°C

Model		Standard dew point -20°C								
		10-IDG3	10-IDG5	10-IDG10	10-IDG20	10-IDG30A	10-IDG50A	10-IDG60	10-IDG75	10-IDG100
Range of operating conditions	Fluid ^{Note 1)}	Compressed air								
	Inlet air pressure (MPa)	0.3 to 0.85			0.3 to 1.0					
	Inlet air temperature (°C)	-5 to 55 (No freezing)				-5 to 50 (No freezing)				
	Ambient temperature (°C)	-5 to 55 (No freezing)				-5 to 50 (No freezing)				
Standard performance conditions	Outlet air atmospheric pressure dew point (°C)	-20								
	Inlet air flow rate (L/min [ANR]) ^{Note 2)}	31	62	125	250	360	586	725	900	1190
	Outlet air flow rate (L/min [ANR])	25	50	100	200	300	500	600	750	1000
	Purge air flow rate (L/min [ANR]) ^{Note 3)}	6	12	25	50	60	86	125	150	190
	Inlet air pressure (MPa)	0.7								
	Inlet air temperature (°C)	25								
	Inlet air saturation temperature (°C)	25								
	Ambient temperature (°C)	25								
	Dew point indicator purge air flow rate	—			1 L/min [ANR] (Inlet air pressure at 0.7 MPa)					
	Port size	1/8, 1/4			1/4, 3/8			3/8, 1/2		1/2
Weight (kg)(With bracket)	0.3 (0.36)		0.5 (0.58)	0.78 (0.88)	1.01 (1.04)	1.04 (1.17)	1.67 (1.82)	1.67 (1.82)	1.72 (1.87)	
Cleanliness class (ISO class)	Class 3									

Note 1) Prevent water droplets from entering the inlet port.

Note 2) "ANR" indicates the flow rate converted to the value at 20°C, under the atmospheric pressure and the state of relative humidity 65%.

Note 3) Includes 1 L/min [ANR] of purge air flow (Inlet air pressure at 0.7 MPa) for the dew point indicator (except 10-IDG3, 10-IDG5).

Standard dew point----15°C/Type H

Model		Standard dew point -15°C								
		10-IDG3H	10-IDG5H	10-IDG10H	10-IDG20H	10-IDG30HA	10-IDG50HA	10-IDG60H	10-IDG75H	10-IDG100H
Range of operating conditions	Fluid ^{Note 1)}	Compressed air								
	Inlet air pressure (MPa)	0.3 to 0.85			0.3 to 1.0					
	Inlet air temperature (°C)	-5 to 55 (No freezing)				-5 to 50 (No freezing)				
	Ambient temperature (°C)	-5 to 55 (No freezing)				-5 to 50 (No freezing)				
Standard performance conditions	Outlet air atmospheric pressure dew point (°C)	-15								
	Inlet air flow rate (L/min [ANR]) ^{Note 2)}	28	56	111	222	329	550	665	830	1110
	Outlet air flow rate (L/min [ANR])	25	50	100	200	300	500	600	750	1000
	Purge air flow rate (L/min [ANR]) ^{Note 3)}	3	6	11	22	29	50	65	80	110
	Inlet air pressure (MPa)	0.7								
	Inlet air temperature (°C)	25								
	Inlet air saturation temperature (°C)	25								
	Ambient temperature (°C)	25								
	Dew point indicator purge air flow rate	—		1 L/min [ANR] (Inlet air pressure at 0.7 MPa)						
	Port size	1/8, 1/4			1/4, 3/8			3/8, 1/2		1/2
Weight (kg)(With bracket)	0.3 (0.36)		0.5 (0.58)	0.78 (0.88)	1.01 (1.04)	1.04 (1.17)	1.67 (1.82)	1.67 (1.82)	1.72 (1.87)	
Cleanliness class (ISO class)	Class 3									

Note 1) Prevent water droplets from entering the inlet port.

Note 2) "ANR" indicates the flow rate converted to the value at 20°C, under the atmospheric pressure and the state of relative humidity 65%.

Note 3) Includes 1 L/min [ANR] of purge air flow (Inlet air pressure at 0.7 MPa) for the dew point indicator (except 10-IDG3H, 10-IDG5H).

Standard Specifications/Single Unit Type (Standard dew point -40°C, -60°C)
Standard dew point....-40°C/Type L

Model		Standard dew point -40°C				
		10-IDG30LA	10-IDG50LA	10-IDG60LA	10-IDG75LA	10-IDG100LA
Range of operating conditions	Fluid ^{Note 1)}	Compressed air				
	Inlet air pressure (MPa)	0.3 to 1.0				
	Inlet air temperature (°C)	-5 to 50 (No freezing)				
	Ambient temperature (°C)	-5 to 50 (No freezing)				
Standard performance conditions	Outlet air atmospheric pressure dew point (°C)	-40				
	Inlet air flow rate (L/min [ANR]) ^{Note 2)}	93	135	224	308	400
	Outlet air flow rate (L/min [ANR])	75	110	170	240	300
	Purge air flow rate (L/min [ANR]) ^{Note 3)}	18	25	54	68	100
	Inlet air pressure (MPa)	0.7				
	Inlet air temperature (°C)	25				
	Inlet air saturation temperature (°C)	25				
	Ambient temperature (°C)	25				
	Dew point indicator purge air flow rate	1 L/min [ANR] (Inlet air pressure at 0.7 MPa)				
	Port size	1/4, 3/8		3/8, 1/2		
Weight (kg)(With bracket)	1.01 (1.04)	1.04 (1.17)	1.73 (1.88)	1.86 (2.01)	1.99 (2.14)	
Cleanliness class (ISO class)	Class 3					

Note 1) Prevent water droplets from entering the inlet port.

Note 2) "ANR" indicates the flow rate converted to the value at 20°C, under the atmospheric pressure and the state of relative humidity 65%.

Note 3) Includes 1 L/min [ANR] of purge air flow (Inlet air pressure at 0.7 MPa) for the dew point indicator.

Standard dew point....-60°C/Type S

Model		Standard dew point -60°C		
		10-IDG60SA	10-IDG75SA	10-IDG100SA
Range of operating conditions	Fluid ^{Note 1)}	Compressed air		
	Inlet air pressure (MPa)	0.3 to 1.0		
	Inlet air temperature (°C)	-5 to 50 (No freezing)		
	Ambient temperature (°C)	-5 to 50 (No freezing)		
Standard performance conditions	Outlet air atmospheric pressure dew point (°C)	-60		
	Inlet air flow rate (L/min [ANR]) ^{Note 2)}	75	140	230
	Outlet air flow rate (L/min [ANR])	50	100	150
	Purge air flow rate (L/min [ANR]) ^{Note 3)}	25	40	80
	Inlet air pressure (MPa)	0.7		
	Inlet air temperature (°C)	25		
	Inlet air saturation temperature (°C)	25		
	Ambient temperature (°C)	25		
	Dew point indicator purge air flow rate	1 L/min [ANR] (Inlet air pressure at 0.7 MPa)		
	Port size	3/8, 1/2		
Weight (kg)(With bracket)	1.73 (1.88)	1.86 (2.01)	1.99 (2.14)	
Cleanliness class (ISO class)	Class 3			

Note 1) Prevent water droplets from entering the inlet port.

Note 2) "ANR" indicates the flow rate converted to the value at 20°C, under the atmospheric pressure and the state of relative humidity 65%.

Note 3) Includes 1 L/min [ANR] of purge air flow (Inlet air pressure at 0.7 MPa) for the dew point indicator.

 Directional Control Valves
 Air Cylinders
 Rotary Actuators
 Air Grippers
 Air Preparation Equipment
 Modular F. R.
 Pressure Control Equipment
 Fittings & Tubing
 Flow Control Equipment
 Pressure Switches/ Pressure Sensors

Dimensions

10-IDG3, 5 10-IDG3H, 5H

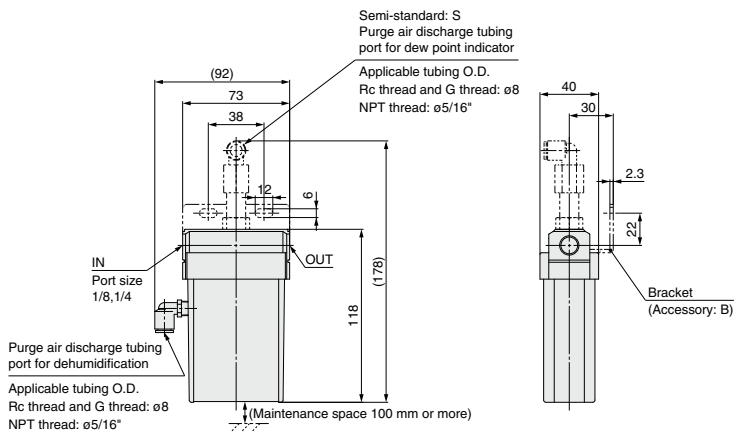

10-IDG10, 10H

10-IDG20, 20H

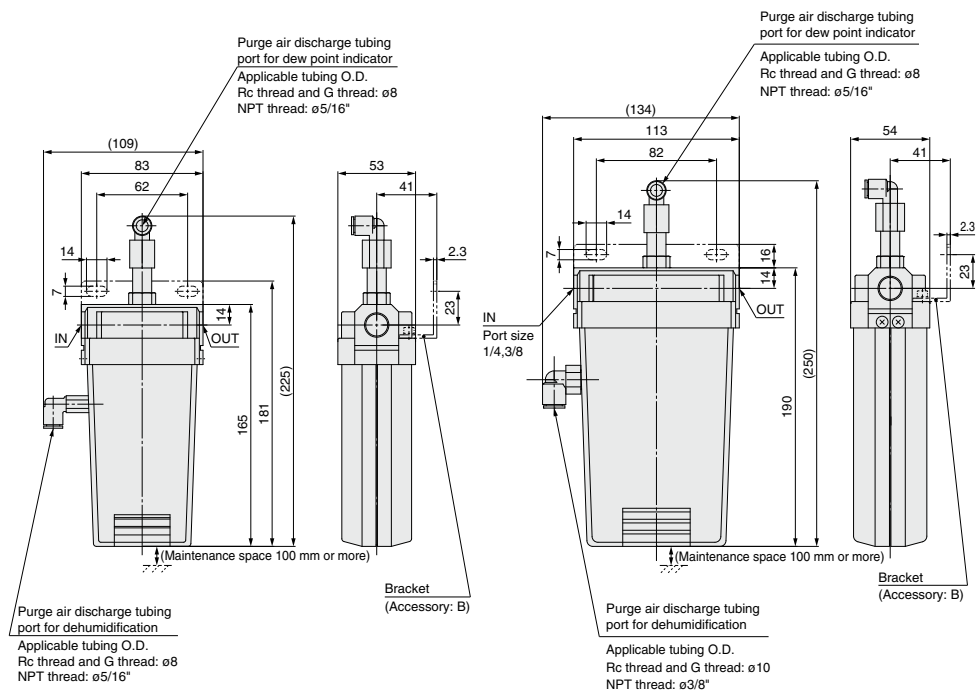

Dimensions

10-IDG30□A, 50□A

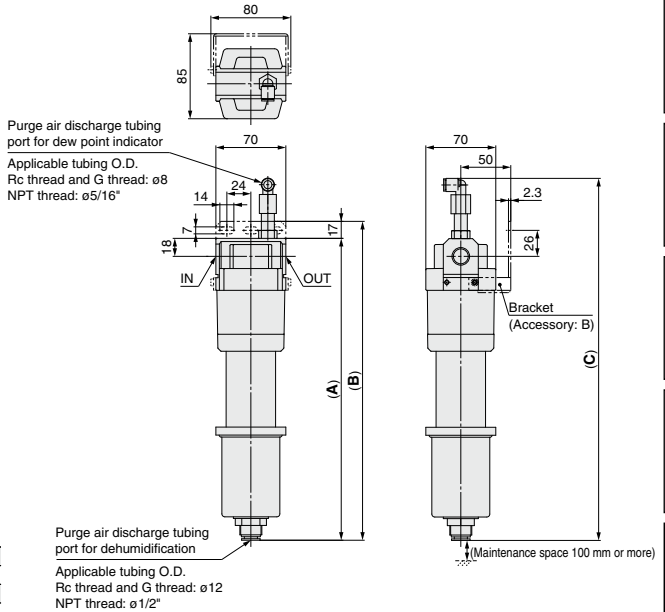

Model	Port size	A	B	C
10-IDG30□A	1/4, 3/8	302	319	362
10-IDG50□A		341	358	401

10-IDG60□, 75□, 100□ 10-IDG60□A, 75□A, 100□A

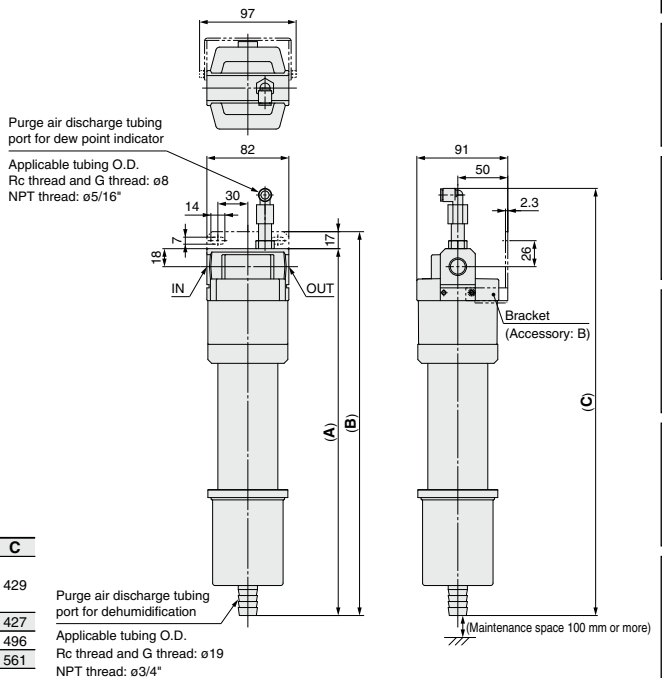

Model	Port size	A	B	C
10-IDG60, 60H	3/8, 1/2	369	386	429
10-IDG75, 75H	1/2			
10-IDG100, 100H				
10-IDG60LA, 60SA	3/8, 1/2	367	384	427
10-IDG75LA, 75SA		436	453	496
10-IDG100LA, 100SA		501	518	561

⚠ Specific Product Precautions

Be sure to read this before handling.

Design

⚠ Warning

- Depending on the model and operating conditions, the oxygen ratio of the outlet air may drop below the prescribed standard.**

Do not use standard dew point -40°C (symbol: L) type, standard dew point -60°C (symbol: S) type and 10-IDG30A, 50A, 30HA, 50HA for dehumidifying breathing air. Do not use only outlet air (dry air) in a closed room.

⚠ Caution

- Install a regulator on the outlet side of the membrane air dryer.**

If it is installed on the inlet side, dehumidification performance will be reduced.

- Devise a layout which considers the position of purge air discharge ports.**

Purge air is humid air. Devise a layout in which purge air will not cause trouble such as corrosion or malfunction of peripheral equipment.

- When highly purified air is required**

(Supply to air bearings, blowing of semiconductor parts, etc.)
Install a micro mist separator or super mist separator on the outlet side (end terminal) of the membrane air dryer (unit).

- Time to reach the standard dew point**

A certain amount of time is required to achieve the standard dew point after the air begins flowing into the membrane air dryer. Using the times below as a guide, begin operating outlet side equipment after the standard dew point is achieved.

Standard dew point -20°C , -15°C : About 10 minutes
 Standard dew point -40°C : About 30 minutes *
 Standard dew point -60°C : About 60 minutes *

* This time can be shortened as described below.

- Provide a valve on the outlet side of the membrane air dryer.
- Supply air with the valve closed. Only purge air flows into the membrane air dryer.
- After 15 minutes or more, open the valve and let air flow to the outlet side equipment.

- Dehumidification performance when inlet air temperature changes**

Performance chart shows the case at an inlet air temperature of 25°C . In other cases, refer to Model Selection (**WEB catalog** or Best Pneumatics No. 5) for proper selection.

Selection

⚠ Caution

- Consider the purge air flow rate.**

Find the purge air flow rate from the charts and calculate the "required outlet air flow rate + purge air flow rate". The air supply capacity must be at least equal to the calculated flow or the required outlet air flow rate cannot be obtained.

- Selection for a compressed air line in which a mist separator or micro mist separator is already installed**

Verify the operating air flow rate and air pressure, and select a membrane air dryer in accordance with Model Selection (**WEB catalog** or Best Pneumatics No. 5). If a membrane air dryer is selected using the port size of the equipment that is already installed as a reference, it could result in the selection of a model that is too small and has an insufficient dehumidification capacity.

Mounting

⚠ Caution

- Do not obstruct the purge air discharge ports.**

Dehumidification performance will decrease or may become impossible if purge air back pressure becomes too high or purge air stops flowing.

- Be sure to install a mist separator and micro mist separator or a micro mist separator with pre-filter on the inlet side of the membrane air dryer.**

If the inlet air contains oil, performance will be reduced.

- Take sufficient care in handling.**

There is a danger of damage if dropped.

- Remove water droplets from the inlet air.**

Water droplets in the air can lower performance and cause malfunction.

⚠ Specific Product Precautions

Be sure to read this before handling.

Piping

⚠ Warning

- Check for tightening of the holder.**
(for 10-IDG30A to IDG100, 10-IDG30HA to IDG100H, 10-IDG30LA to IDG100LA, 10-IDG60SA to IDG100SA)
Before starting the flow of compressed air, turn the membrane air dryer's holder in its tightening direction, confirming that it is completely tightened and that the case will not come off.
- Piping for dehumidification purge air outlet**
The piping of purge air for dehumidification and for the dew point indicator can be combined, but do not combine it with compressed air lines or drain piping. As this can cause damage.

⚠ Caution

- Use of tools**
Hold the upper portion of the body (aluminum die-casted section) with a wrench or adjustable angle wrench. Do not turn it while holding the case section.
- Piping materials for low dew point air**
If air of a low dew point (−40°C or less) is required, do not use a nylon tube piping and resin fittings (except fluoropolymer) for the outlet side of the membrane air dryer. Due to the nature of the nylon tube, it could be affected by the ambient air, and it might not be possible to achieve the prescribed low dew point at the end of the tube. Therefore, for low dew point air, use a stainless steel or fluoropolymer piping.

3. Length of the connecting tube for dehumidification purge air outlet

The dehumidification capacity decreases in proportion to the length of the tube for discharging purge air. Use a tube of the specified size and keep its length within 5 m. For the outlet air atmospheric pressure dew point in relation to the length of the tube for discharging purge air, refer to the table "regarding the outlet air atmospheric dew point in relation to the tube length for purge air discharge" on **WEB catalog** or Best Pneumatics No. 5.

4. Connection of purge air discharge tubing (for 10-IDG60 to IDG100, 10-IDG60H to IDG100H, 10-IDG60LA to IDG100LA, 10-IDG60SA to IDG100SA)

To install piping for dehumidification purge air discharge, attach tubing of the prescribed size to the hose nipple section and then secure it with tubing bands.

Air Supply

⚠ Caution

- Compressed air supply capacity**
An air source that has a supply capacity that is larger than the "required outlet air flow rate (dry air flow rate) + purge air flow rate" is required. Verify the purge air flow rate in Purge Air Flow-rate Characteristics. (**WEB catalog** or Best Pneumatics No. 5)
- Chemicals with a negative effect on this product**
Chemicals listed in the table below in the compressed air can lower performance and damage the element. Do not use the product in environments including these chemicals.

Category	Chemicals not to be included
Solvents	Acetone, benzene, phenol, toluene, trichloroethylene, xylene, cresol, thinner, aniline, chloroform, chlorobenzene, trichloroethane, ethylbenzene, ethyl alcohol, methyl alcohol, isopropyl alcohol, dioxin, tetrahydrofuran, methylene chloride, cyclohexane, carbon tetrachloride, methyl ketone, ethyl ketone, hexafluoroisopropanol, and others
Acids	Sulfuric acid, nitric acid, hydrochloric acid, acetic acid, lactic acid, chromic acid, and others
Gases	Chlorine gas, sulfurous acid gas, hydrogen chloride, bromine, ozone, ammonia, and others
Oils	Phosphoric-ester hydraulic oil, fuel oil, water soluble cutting oil (alkaline), kerosene, and others
Strong bases	Lithium hydroxide, sodium hydroxide, potassium hydroxide, calcium hydroxide, and others
Others	Anaerobic adhesive, anaerobic sealant, and others

Operating Environment

⚠ Caution

- Do not use at temperatures (fluid or ambient temperatures) higher than the prescribed operating conditions.**
Resin is used in the membrane module, and it can be damaged by operation at high temperatures. Especially when installed immediately after a reciprocating type air compressor, confirm that the fluid temperature does not exceed the range of operating conditions during use.
- Keep the inlet air temperature lower than the ambient temperature.**
If the membrane air dryer body is cooled by the surrounding air, water drops may accumulate inside and reduce its dehumidification capacity.

Directional Control Valves

Air Cylinders

Rotary Actuators

Air Grippers

Air Preparation Equipment

Modular F. R.

Pressure Control Equipment

Fittings & Tubing

Flow Control Equipment

Pressure Switches/ Pressure Sensors

Precautions

Be sure to read this before handling.

Maintenance

Caution

1. **Confirm that the equipment's pressure is at zero and no longer in a pressurized state before removing any parts or piping. Performing any work while pressure remains in the equipment may lead to injury or product damage.**

2. **When replacing the membrane module**

For modular connections, be sure to remove the membrane air dryer before attempting any replacement work.

3. **About the dew point indicator**

You can use the dew point indicator to confirm the state of the outlet air of the membrane air dryer.

· When the absorbent is blue or pink

[Dew point indicator is blue] Dry state

[Dew point indicator is pink] Wet state

· When the absorbent is green or yellow

[Dew point indicator is green] Dry state

[Dew point indicator is yellow] Wet state

It takes time for the dew point indicator's color to change.

Absorbent is used in the dew point indicator. When it absorbs vaporized oil content or other gaseous components in the compressed air, it may turn a color other than blue (green) or pink (yellow).